



First choice
of any chef



Two brands - Trufrost and Butler team up to provide a comprehensive bouquet of products designed to provide a cutting edge to commercial kitchens, cloud kitchens, industrial canteens and QSRs. Products that will cook and cool and let you breathe easy by their tireless performance, extraordinary features and dependable service.



CONTENTS

Professional Refrigeration	6
Blast Chillers/Shock Freezers	26
Cold Rooms	35
Ice Machines	50
Combi Steamers	64
Induction Systems	71
Catering Equipment	83
Ventless Speed Ovens	107
Bakery Equipment	110
Food Preparation Equipment	122
Flat Packed SS Furniture	128
Refrigerated Paan Displays	129
Hygiene Solutions	131
When it all comes together	138

Cutting edge solutions for cooling & cooking

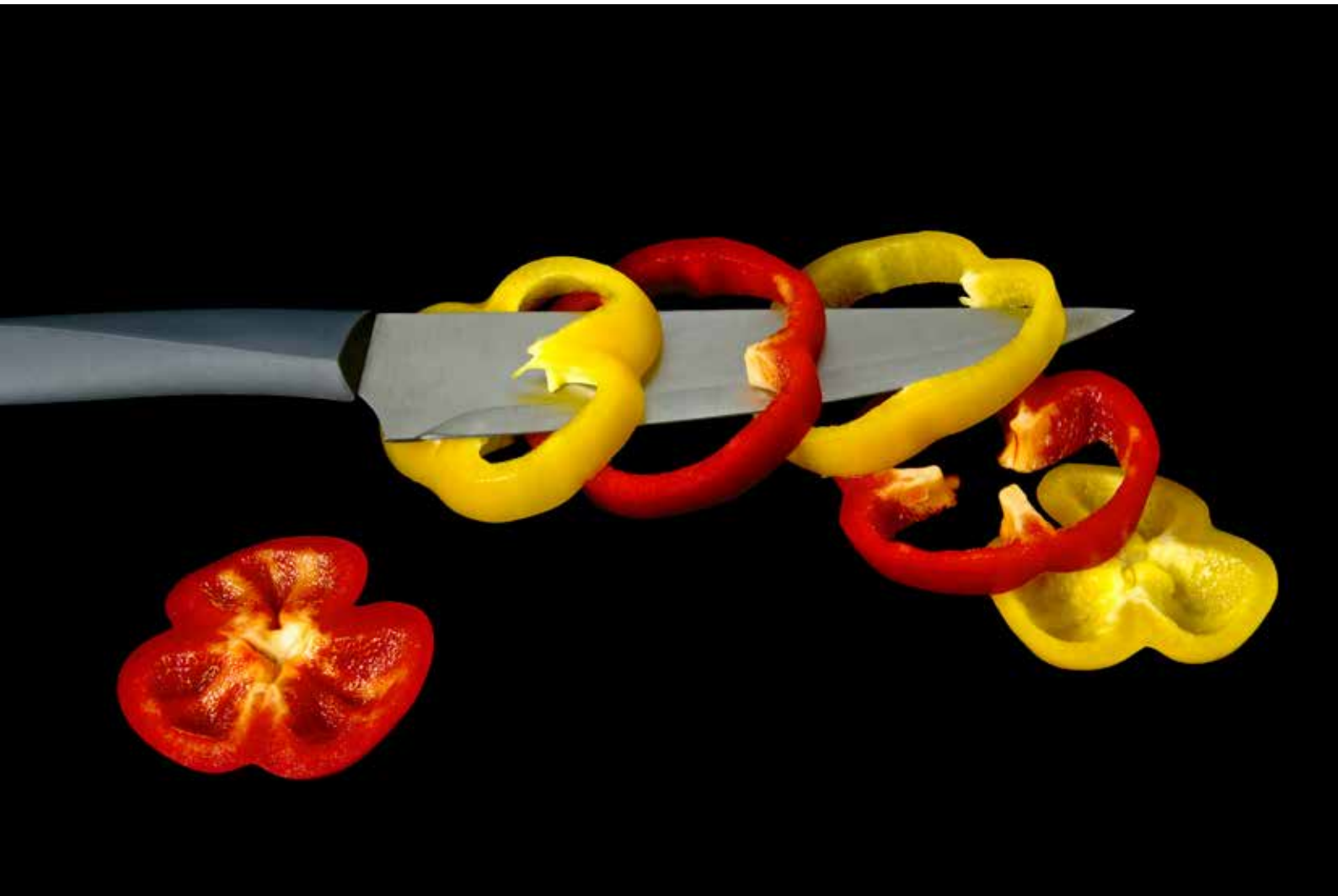

Refrigeration solutions designed for tropical conditions



Reach in Cabinets

These Trufrost Reach-Ins are available as Chillers or Freezers, and come with 1, 2 or 4 door options. Available in a choice of two refrigeration systems - Ventilated or Static with fan, these are offered in capacities ranging from 600 - 1350 litres. There are different models to address the wide-ranging needs right from the professional kitchen of a 5 star hotel to a café or a restaurant.



Available Models

G 600 TNM, STF 600 TNM, GN680TNM,
G 600 BTM, GN680BTM, STF 600 BTM



Available Models

G 1200 TNM, STF 1200 TNM, GN1340TNM,
G 1200 BTM, STF 1200 BTM, GN1340BTM,
G 1210 BTM



Reach in Cabinets with Glass Doors

These Trufrost Reach-Ins are available in 1 or 2 glass door options. Available in a choice of two refrigeration systems - Ventilated or Static with fan, these are offered in capacities ranging from 600 - 1410 litres. They are designed to address the wide-ranging needs right from the professional kitchen of a 5 star hotel to a café or a restaurant.



GN 740 TNG, GN 740 BTG



GN 1480 TNG, GN 1480 BTG



Technical Specifications



Product	Model	Dimensions (wxdxh) mm	Internal Dimensions	Volume (L)	Cooling System	Refrigerant	Input Power (W)	Temperature Range (°C)	GN Compatibility	No. of Door/Drawers	No. of Shelves	Net Weight (Kg)
Reach In Refrigerators	G 600 TNM	680x710x2010	-	600	Ventilated	R600a	220	-2 ~ +8	-	2	4	115
	STF 600 TNM	680x710x2010	564x582x1394	600	Static with fan	R290	185	-2 ~ +8	-	2	3	115
	GN 680 TNM	680x810x2010	564x682x1394	680	Ventilated	R290	210	-2 ~ +8	GN 2/1	2	3	115
	G 1200 TNM	1340x710x2010	-	1200	Ventilated	R134a	465	-2 ~ +8	-	4	6	152
	STF 1200 TNM	1200x700x1950	1100x540x1380	1210	Static with fan	R134a	400	-5 ~ +5	-	4	6	115
	GN 1340 TNM	1340x810x2010	1224x682x1394	1340	Ventilated	R290	430	-2 ~ +8	GN 2/1	4	6	167
Reach In Freezers	G 600 BTM	680x710x2010	-	600	Ventilated	R290	415	-22 ~ -18	-	2	3	126
	STF 600 BTM	680x710x2010	564x582x1394	600	Static with fan	R290	435	-20 ~ -15	-	2	3	155
	GN 680 BTM	680x810x2010	564x682x1394	680	Ventilated	R290	465	-22 ~ -18	GN 2/1	2	3	126
	STF 1200 BTM	1340x710x2010	1224x582x1394	1200	Static with fan	R290	626	-20 ~ -15	-	4	6	155
	G 1200 BTM	1340x710x2010	-	1200	Ventilated	R 404a	580	-22 ~ -17	-	4	6	161
	G 1210 BTM	1200x740x1950	-	1210	Ventilated	R 404a	550	-22 ~ -17	-	4	6	160
	GN 1340 BTM	1340x810x2010	1224x682x1394	1340	Ventilated	R290	730	-22 ~ -18	GN 2/1	4	6	177
Double Temperature Reach In Cabinet	STF 1200 DT-M	1200x700x1950	525x540x1380 (x2)	1200	Static with fan	R134a	500	-18 ~ -12/ -5 ~ +5	-	4	6	135
Reach In Refrigerators with Glass Door	GN 740 TNG	740*830*2010	-	700	Ventilated	R 134a		2 ~ +10	GN 2/1	1	3	
	GN 740 BTG	740*830*2010	-	700	Ventilated	R 134a		-15 ~ -18	GN 2/1	1	3	
	GN 1410 BTG	1480x830x2010	1364x702x1401	1276	Ventilated	R290	865	-18 ~ -15	GN 2/1	2	6	232
	GN 1410 TNG	1480x830x2010	1364x702x1401	1276	Ventilated	R290	415	+2 ~ +8	GN 2/1	2	6	208

Electricals: 220V/50Hz/1 Phase

GN series comes with SS-304 inside

Specifications are subject to change without prior notice due to continuous product development



Refrigerated Work Tables

Trufrost refrigerated worktables, or refrigerated undercounters as they are also called, combine storage and preparation thereby enhancing the effectiveness of kitchen professionals. They are mounted on heavy duty lockable castors for ease of mobility and cleaning. Available in a choice of two refrigeration systems - Ventilated or Static with fan, these Chillers or Freezers are available in 2 and 3 door options. Options of back splash and a set of 2 or 3 drawers in place of a hinged door are available at an extra cost for project orders.



Available Models

G2100TN, GN 2100 TN, STF 2100TN,
G2100BT, GN 2100 BT



Available Models

G3100TN, GN 3100 TN, STF 3100TN,
G3100BT, GN 3100 BT



Available Models

S 901



Customisation for project orders

While the standard undercounters come with hinged doors but for large project orders with a lead time, Trufrost offer variations such as a set of 2 or 3 drawers in place of a hinged door and options of a backsplash at an extra cost. For model S 901, only a set of 2 drawers can be provided in place of a door.



Set of 2 drawers in place of hinge door



Set of 3 drawers in place of hinge door



With backsplash

Efficiency in preparation





Saladettes

Trufrost Saladettes come with a refrigerated display top and a night cover that can take in various toppings, salads and more. S 900 comes with pan supports for 1 x GN 1/1 pan, 3 x GN 1/3 pans and 3 x GN 1/6 pans. S 903 comes with pan supports for 1 x GN 1/1 pan, 4 x GN 1/2 pans and 3 x GN 1/3 pans (not included). The refrigerated section in its underbelly is good for additional storage.



S 900 (2 doors)



S 903 (3 doors)





Preparation Counters -Ventilated

These Ventilated Preparation Counters from Trufrost come in 2 & 3 door variants and bring in an exceptional efficiency to the preparation of pizzas, salads, starters, sandwiches, desserts and more. SH 2000 & 3000 models are large enough to house 8 & 10 GN 1/3 pans respectively on their decks.



SH-2000/800



SH-3000/800



Preparation Counters – Static Cooling

Trufrost Preparation Counters with static cooling come in 2 & 3 door variants and bring in an exceptional efficiency to the preparation of pizzas, salads, starters, sandwiches, desserts and more. PS 200 & 300 are compact counters that can house 5 & 8 GN 1/6 pans respectively on their decks.



PS-200



PS-300



STAUB

Countertop Cold Display

Trufrost Countertop Cold Display is a versatile appliance. Apart from salads, starters and toppings, it is also ideal for storing a variety of Indian Desserts like kheer, rabadi, rasogullas, ras-malai and phirni on one hand to pani-poori, jal jeera on the other. They accept 5 GN 1/4 pans (not included) and come with a glass sneeze-guard.



VRX-1200/330



Inviting display for your
exquisite sushi



Countertop Sushi Display

Apart from being a point of attraction on the sushi counter, a Trufrost Sushi Showcase ensures the freshness of foodstuff. Designed with an elegant curved glass, its powerful cooling performance coupled with stable humidity & temperature control keeps sushi fresh and keeps it from drying out. It comes loaded with 5 GN ¼ pans.



CTSS-5



Technical Specifications



Product	Model	Dimensions (WxDxH) mm	Internal Dimensions (WxDxH) mm	Volume (L)	Cooling System	Refrigerant	Input Power (W)	Temperature Range (°C)	GN Compatibility	No. of Door/ Drawers	No. of Shelves	Net Weight (Kg)
Undercounter Refrigerators	S 901	900x700x850	830x595x455	240	Static with fan	R600a	170	+2 ~ +8	GN 1/1 Shelf per door	2	2	81
	STF 2100 TN	1360x600x850	799x480x564	228	Static with fan	R290	255	-2 ~ +8	-	2	2	89
	STF 3100 TN	1800x700x800	1400x529x582	340	Static with fan	R134a	400	-5 ~ +5	-	3	6	107
	G 2100 TN (New)	1360x600x860	902x430x560	228	Ventilated	R600a	275	-2 ~ +8	-	2	2	94
	GN 2100 TN (New)	1360x700x860	902x530x560	282	Ventilated	R600a	275	-2 ~ +8	GN1/1	2	2	92
	G 3100 TN (New)	1795x600x860	1337x430x560	339	Ventilated	R600a	275	-2 ~ +8	-	3	3	127
	GN 3100 TN (New)	1795x700x860	1337x530x560	417	Ventilated	R600a	275	-2 ~ +8	GN1/1	3	3	114
Undercounter Freezers	G 2100BT	1360x600x850	799x480x564	228	Ventilated	R290	520	-22 ~ -18	-	2	2	107
	G 2100BT (New)	1360x600x860	902x430x560	228	Ventilated	R290	675	-18 ~ -22	-	2	2	95
	GN 2100BT	1360x700x850	799x580x564	282	Ventilated	R290	520	-22 ~ -18	GN1/1	2	2	107
	G 3100BT (New)	1795x600x860	1337x430x560	339	Ventilated	R290	675	-18 ~ -22	-	3	3	129
	GN 3100BT	1795x700x850	-	417	Ventilated	R404a	620	-10 ~ -20	GN1/1	3	3	117
	GN 3100 BT (New)	1795x700x860	1337x530x560	417	Ventilated	R290	675	-18 ~ -22	GN1/1	3	3	124
Saladette	S 900	900x700x876	830x595x455	240	Static with fan	R600a	170	+2 ~ +8	GN 1/1 Shelf per door	2	2	81
	S 903 (New)	1365x700x875	1295x595x500	368	Static	R290	435	+2 ~ +10	GN 1/1 Shelf per door	3	3	104
Refrigerated Chef Tables / Drawers	CT 36	925x815x650	-	134	Ventilated	R134a	363	+3 ~ +10	YES	2	-	100
Preparation Counters	SH 2000/800 (New)	1510x800x1085	1052x630x560	390	Ventilated	R290	340	-2 ~ +8	-	2	2	138
	SH 3000/800	2025x800x1070	1605x584x586	650	Ventilated	R134a	360	-2 ~ +10	-	3	3	160
	SH 3000/800 (New)	2020x800x1085	1052x630x560	580	Ventilated	R290	360	-2 ~ +8	-	3	3	180
	PS 200	900x700x970	830x595x510	240	Static	R134a	300	+2 ~ +10	GN 1/1 Shelf per door	2	4	68
	PS 300	1365x700x970	1295x595x455	392	Static with fan	R290	240	+2 ~ +8	GN 1/1 Shelf per door	3	3	104
Countertop Display	VRX 1200 (Glass)	1200x335x435	-	-	Static	R134a	115	+2 ~ +10	GN 1/4	-	-	-
Countertop Sushi Display	CTSS-5	1200*335*430	-	52	Static	R134a	135	+2 ~ +10	#	-	-	60

Electricals: 220V/50Hz/1 Phase GN series comes with SS-304 inside # Please refer to information given next to the product picture.

Specifications are subject to change without prior notice due to continuous product development





GN Sizes – What do they all mean?

GN is short for Gastronorm, which is used to measure the size of trays, pans and containers that are created to an industry standard by the European Standards Committee.

There are 9 different sizes, which are based on the outer dimensions of the container. GN containers are available in a variety of depths, enabling them to be used for a wide range of foodstuffs, and in various pieces of equipment.

GN pans are used, not only for heating but also for storage when refrigerating, displaying in self-service environments and storing warm food for service. They are generally available in stainless steel, polycarbonate, melamine, polypropylene and even porcelain.

Another benefit of using GN pans is that they are modular by design. Since GN pans are all based on fractions, you can flexibly combine containers together to suit your needs.

Size	Dimensions	
GN 1/1	530 × 325mm	Full GN
GN 1/2	325 × 265mm	Half GN
GN 1/4	265 × 162mm	Quarter GN
GN 2/1	650 × 530mm	Double GN
GN 1/3	325 × 176mm	1 Third GN
GN 2/3	354 × 325mm	2 Thirds GN
GN 2/4	530 × 162mm	
GN 1/6	176 × 162mm	
GN 1/9	108 × 176mm	

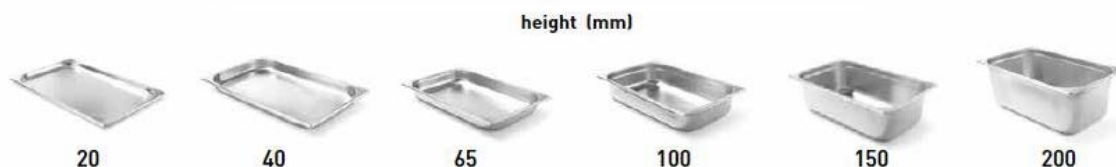



Why use a Blast Chiller or Freezer?

Food safety is paramount in all food industries. Bacteria multiplies very fast between $+8^{\circ}\text{C}$ and $+68^{\circ}\text{C}$. The faster cooked food chills and passes through this danger zone, the less chance there will be of bacteria growth.

Standard storage refrigerators and cold rooms are designed for holding previously chilled foods, but not for chilling hot foods. Placing hot food in refrigerators or cold rooms that may already be holding chilled foods is fraught with risk. It can cause the temperature of previously chilled foods to rise thereby triggering bacterial contamination of all products in the cabinet. That is what triggers the need for rapid cooling.



Trufrost Blast Chillers/Freezers

The Trufrost Blast Chiller / Freezer is a revolutionary appliance which rapidly lowers the core temperature of foods (chilling from +90°C to +3°C in 90 minutes, freezing from +90°C to -18°C in 240 minutes), thus allowing perfect preservation and eliminating bacterial growth. It is an ideal appliance for chefs, pastry chefs and ice cream makers who need reliability, convenience and improved efficiency, without compromising on food quality.



BCF-5
Yield per cycle 20 kg



BCF-10
Yield per cycle 40 kg



BCF-13
Yield per cycle 60 kg

Blast Chilling

from +90°C to +3°C in 90 minutes

This process helps lower the food temperature to safe +3°C in a suitably short time, in line with HACCP standards. The adequate chilling speed helps reduce bacteria growth in the range from +65°C to +10°C. Blast chilling helps retain the quality, colour and smells of food and extends the storage period. In

Shock Freezing

from +90°C to -18°C in 4 hours

Blast freezing results in a large number of small crystals preserving the original properties of food: avour, colour, texture and nutrients, and helps extends the storage period. This enables you to store the foods ready for thaw, regeneration and service for up to several months. Blast freezing can also be applied for raw materials and semi-cooked foods.

(Please ensure that the foodstuff to be blast chilled/frozen in these models is placed in open condition in the trays, and not in packages)

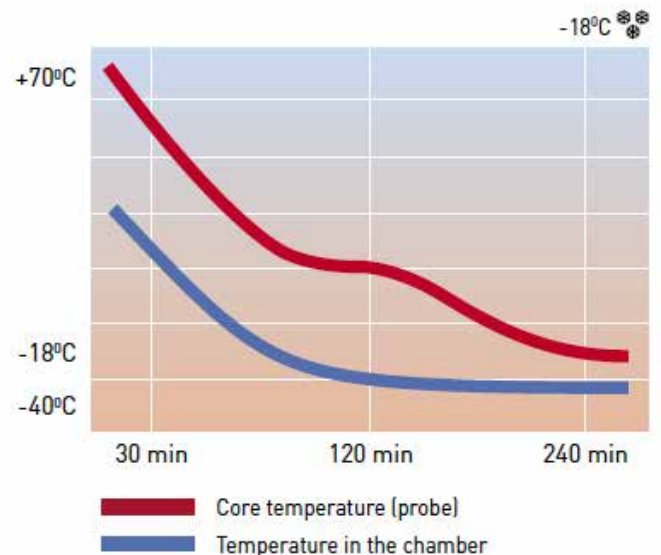
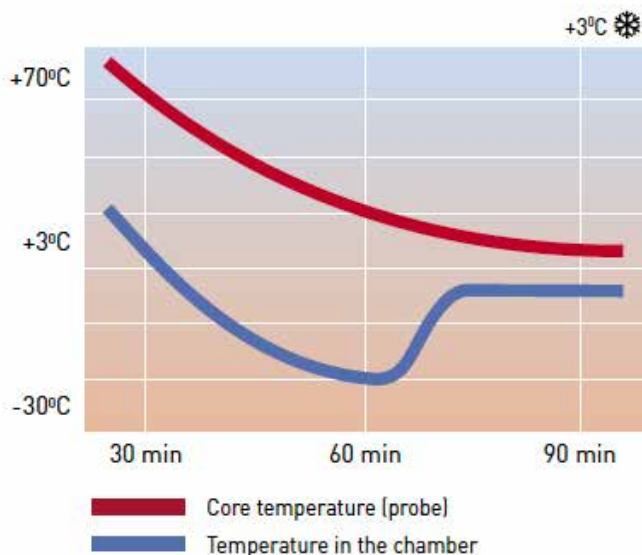

What can you blast freeze?

A great benefit of blast freezing is the variety of goods you can prepare and freeze in advance. You might be surprised at just how much you can store safely for weeks and months at a time. Below list is just some of the most popular food items caterers choose to blast freeze.



Raw & cooked meat, fish and poultry

Just like a regular domestic freezer, blast freezers are perfect for storing raw and cooked produce for use at a later date. A blast freezer can help to extend the life of meat, fish and poultry substantially whilst not compromising on flavour or food safety.

Fresh fruits & vegetables

Whole and pre-cut fruits and vegetables such as berries, chopped carrots, broccoli and peas are all suitable for blast freezing if stored correctly. They can be thawed to be eaten as is or added into soups, smoothies and other cooked meals.



Baked foods

Other helpful 'prepare ahead' items for caterers include breakfast pastries, pies, canopies and savouries. These popular buffet foods are often overlooked when it comes to freezing ahead. Like other foods, bakery produce will freeze best if stored correctly.

Ready meals

Blast freezers are useful to help store full, ready cooked meals ahead of time, and are handy when serving large volumes, daily. Blast freezing ready meals is particularly useful for catering in industrial canteens, schools or hospitals, as you can freeze and thaw full meals without losing that all-important nutritional content.



Ice Cream

When ice cream comes out of the batch freezer, you need to bring its temperature down to -14°C for display or -18°C for storage. Shock freezing brings it to -18°C in the shortest possible time. Free water turns into micro-crystals, which preserve the product, preventing changes to its quality, consistency, texture and allows your ice cream to maintain its 'overrun'.

Use of Blast Chiller /Freezer in various applications

Gastronomy



Bakery



Confectionery



Ice Cream



Benefits of using a Blast Chiller /Freezer

- ◆ Reduce deterioration of products during the freezing process
- ◆ Increase the shelf life of the food product
- ◆ Maintain food quality including flavour, texture, colour, aroma and nutrients
- ◆ Save money making use of seasonal and bulk offers
- ◆ Save labour by enabling larger batch production
- ◆ Reduce waste of unwanted products and preserve for later use
- ◆ Enables preparation and storage during less busy periods

Technical Specifications



Model	Cooling System	Dimensions W*D*H (mm)	Pan Supports EN & GN 1/1		Chilling Capacity +70°C to +3°C	Freezing Capacity +70°C to -18°C	Refrigerant	Input Power (W)
			40mm deep	65mm deep				
BCF-5	Ventilated	800*800*990	5	3	20kgs in 90mins	15kgs in 240mins	R404a	760
BCF-10	Ventilated	800*800*1520	10	7	40kgs in 90mins	28kgs in 240mins	R404a	1500
BCF-13	Ventilated	800*800*1780	13	9	60kgs in 90mins	38kgs in 240mins	R404a	1860

Electricals: 220V/50Hz/Single Phase

Pans not supplied with machine

Specifications are subject to change without prior notice due to continuous product development



Волл Пингопи

© 2021 Волл Пингопи. Все права защищены.
Волл Пингопи - это не просто еда, это искусство.
Мы используем только самые свежие ингредиенты.
Для заказа позвоните по телефону +375 29 500 00 00.
Адрес: г. Минск, ул. Советская, д. 100.

Roll-in Blast Chillers/Freezers

Our roll-in range of blast freezers for trolleys are designed to address the needs of medium to large-scale food preparation areas, from restaurant kitchens to semi-industrial bread and pastry manufacturers.

Built entirely in AISI 304 stainless steel, these blast freezers come with touch-screen controls. They are fitted with insulated floor with ramps for trolleys and high-performance condensing units. Their modular construction design allows easy transportation and flexible installation.





Key Features: Roll-ins

- ◆ Choice of Blast Chiller /Freezer models (90kg to 320kg) to accommodate 2/1 GN size trolley (Trolley is not included)
- ◆ Foodsafe 304 grade stainless steel exterior and interior
- ◆ Easy to use, control panel with LED Display
- ◆ Cam-lock modular panels allow the ease of on-site installation and disassembly for delivery
- ◆ Advanced airflow design enabling uniform freezing
- ◆ Easy to access evaporator for servicing and maintenance
- ◆ Automatically switches to storage mode at the end of each cycle before transfer to appropriate storage cabinet
- ◆ Removable balloon type magnetic door gasket for ease of cleaning & replacement
- ◆ Environmental-friendly CFC-free refrigerant (R404a)



The art & science of keeping fresh





The Coldroom Experts

Team Trufrost has an expertise in design, supply, installation and after-service for your coldroom needs. Having worked extensively in the cold chain industry for over 3 decades, we've devoted ourselves to creating products and solutions that are extremely dependable. Our team has done extensive work with leading brands like Google, Bahrain International Airport, Hyatt, Hilton, Marriott, Taj Hotels, Leela, Sanofi, Johnson & Johnson, Ranbaxy, Dinshaw's, Radisson, Westin, IBIS, Haldiram, Curefit, Ramada, ITC, Oberoi, Cisco and many more names.





Walk-in Coldrooms

We specialize in preservation & storage of products ranging from hospitality, frozen foods, fresh produce, dairy products, beverages, to medicines & vaccinations and more. Be it small walk-in coolers & freezers, or large refrigerated warehouses, Trufrost Coldrooms are easy to install, use, and maintain, keeping you up and running from the very start.



Key Features - Trufrost Coldrooms

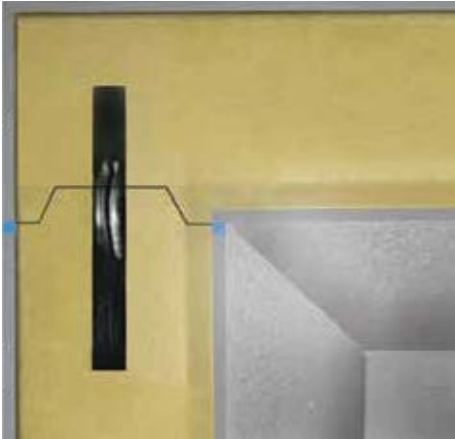

Cam Locking & Gaskets

Our camlocks ensure strong, perfect alignment of all joints. Food-grade PVC gaskets make them neat & leak-proof and are a superior replacement of silicon sealants.



Rounded Corners

Trufrost gives you the option of rounded corner and T-joint on wall to wall, wall to ceiling (only imported) and wall to floor sections that enables easy cleaning of corners and utmost hygiene in your cold room.

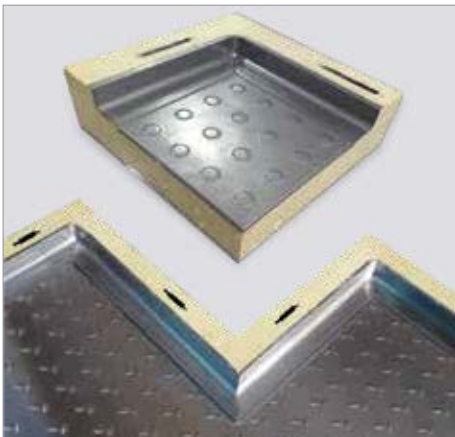

Custom Built Panels

Trufrost PUF Panels can be made to suit your layout design and site conditions. Our sizes are flexible and use L, T and + shape panels to ensure the cold rooms are structurally strong, rivet-free and hygienic.



Inside & Outside Ramp

Site conditions are often not perfect but you may still need to move in and out of cold rooms frequently. Trufrost custom designed ramps ensure that you cart out your foodstuff on trolleys, unhindered.



Key Features - Trufrost Coldrooms



Sliding Doors

Perfect solution for tight alleys but a wider opening requirement. Trufrost offers heavy duty sliding doors with highly durable, European accessories.



Shelving System

Trufrost offers shelving for cold rooms with option of SS304 or SS201. We offer you optimal storage system to maximise space utilisation in a coldroom to suit different budgets.



Control Panel (with I.O.T.)

Our control panels are designed to maximise the performance of all types of refrigeration systems. Optional features of remote monitoring and BMS compatibility are available.



LED lighting (optional)

Energy saving LED lighting options designed for damp, wet, walk-in coolers or freezers applications are available from Trufrost. We also offer IP65 lighting.



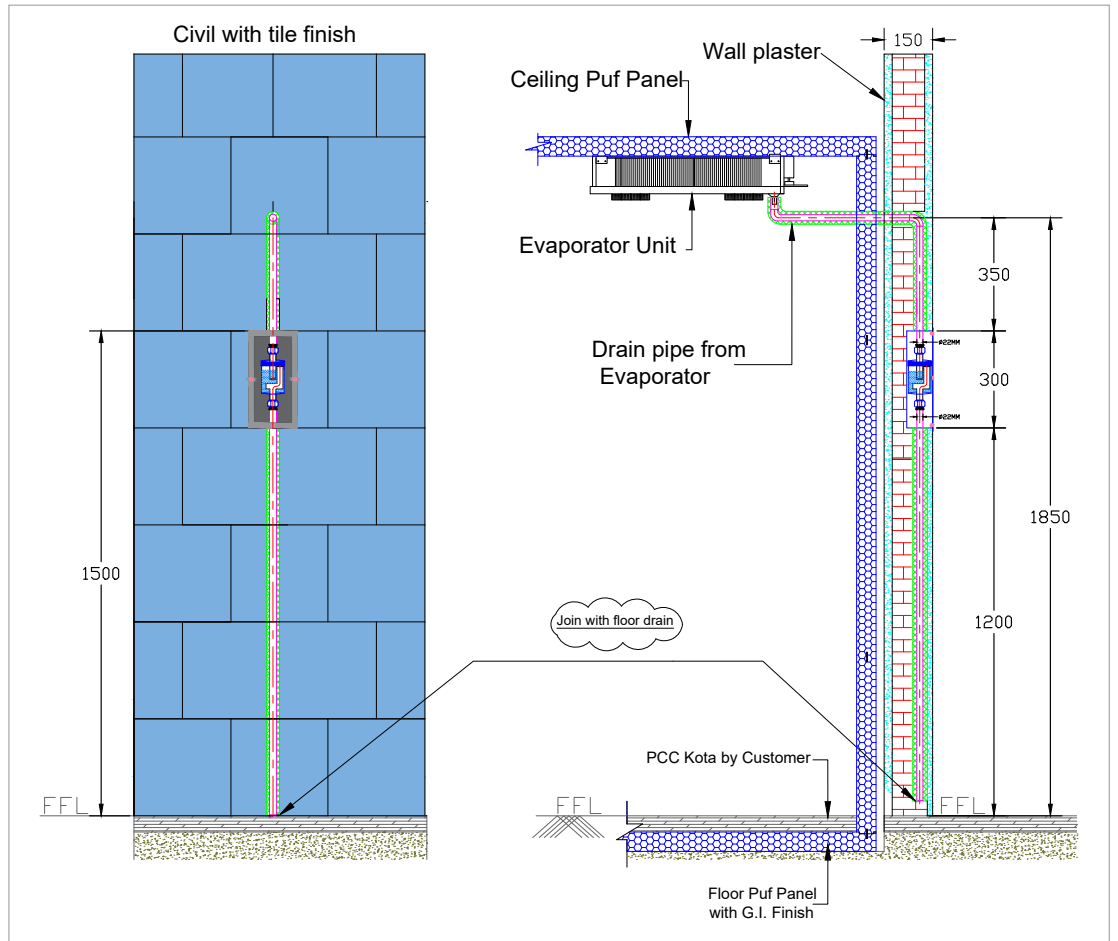
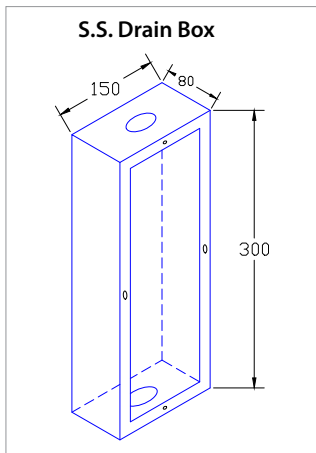
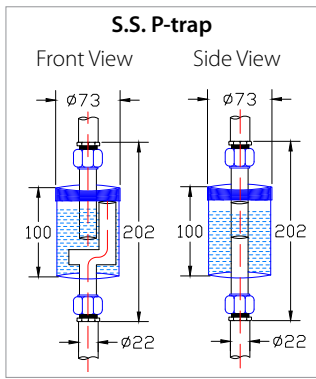

Wall Drain System



Flush door with accessories

- Pressure Relief Port
- Door Closure
- Optional View Port
- Temperature Indicator
- Light Switch
- Overlap Handle
- Kick Plate
- Self Lift Hinges



Variety of doors & accessories options

- ◆ Hinge Doors
- ◆ Sliding Doors
- ◆ High Speed Roll-up Doors
- ◆ Flip-flap Doors
- ◆ Sectional Doors
- ◆ Service Doors
- ◆ Dock Seal
- ◆ Dock Levelers





Evaporators

Trufrost is known for high quality evaporator units suited to site requirements, using Sim or low profile, with low energy fans, where available.

Slim

This is a long, slim, compact evaporator for maximising head and storage height below the evaporator and is suitable for the majority of standard commercial coldroom applications.



Cube

These low profile evaporators are ideal for small size cold and freezer rooms. You can use full size shelving to maximise your storage space.



Taper

These are for medium sized cold rooms for all applications with high and low humidity.



Boxer & Hyper

Large commercial, industrial and specialist application type evaporators with high air velocity for greater air throw distances with medium to low temperature and low to high humidity.





Condensing Units

Trufrost offers a variety of condensing units. Their selection is based on cold room size and usage.

Air Cooled Semi-hermetic: these are generally for small to industrial applications, excessive pipe run or vertical lift distances and speciality blast chilling and freezing applications. They are highly efficient and perform tirelessly.



Air Cooled

Water Cooled Semi-hermetic: these are similar to above and use water from cooling tower or chiller to further improve the efficiency.



Water Cooled

Reciprocating Hermetic: for standard cold rooms with split type remote unit application. These are economical and easy to install.

Hermetic Scroll: for medium to larger rooms, longer horizontal pipe runs and speciality applications such as blast chilling and medium temperature application.



Hermetic Recip/Scroll



Ecostar

Inverter refrigeration system

The new Bitzer Ecostar from Germany comes with inbuilt variable frequency inverter that can reduce your operating cost by up to 30%. This can operate between 25 to 87 Hz frequency and it is 'plug & play'. These are compact, top discharge units that can be kept next to wall, hence space saving. A single system can run upto 6 cold rooms or 4 freezer rooms and is ideal for hotels and warehousing.



Ecolite

With capacity control

The Bitzer Ecolite air cooled CDUs from Germany are highly flexible, sustainable and easy to install. These plug & play machines come with smart Bitzer controller allowing simple implementation in the cooling system and constant monitoring of operating parameters and settings. A single system can run upto 6 cold rooms or 4 freezer rooms and is ideal for hotels and banqueting applications.



Bitzer Rack Systems

The Bitzer Multipac & Hyperpac, multi compressor rack system comes with the proven series of new Bitzer Ecoline Semi Hermetic compressors & Screw compressors. They are surprisingly compact, yet solidly built and are known for enhanced performance and reduced pipe work.

Varipac: Addition of an inverter in the rack enhances its efficiency and increases the life of the system.



Technical Specifications

Model No. Cond. Unit	Model No. Evapo. Unit	Refrigeration Capacity BTU/Hr.	Max. Room Volume (CFT)	Max.Room Area with 8'Ht. (Sq.Ft.)	Temp. Range (C)	Max. Loading (Kgs./Day)	Loading Temp. (C)	Ambient (C)	Power Supply (V/Ph/Hz)	Power* Consumption (Kw)	Defrosting (Type)	Approx. weight (Kgs.)
TH-AH-008-21	Slimmer-S2-08-AL	8000	525	65	2 to 6	300	30	38 to 43	230/1/50	1.6	Off-cycle	70
TH-AH-012-21	Slimmer-S3-12-AL	12000	1000	125	2 to 6	580	30	38 to 43	230/1/50	2	Off-cycle	90
TH-AH-015-21	Slimmer-S4-16-AL	15000	1400	175	2 to 6	810	30	38 to 43	230/1/50	2.5	Off-cycle	110
TH-AH-019-23	Slimmer-S5-20-AL	19000	1900	240	2 to 6	1115	30	38 to 43	400/3/50	3	Off-cycle	148
TH-AH-021-23	Boxer-K34-21-AL	21000	2200	275	2 to 6	1278	30	38 to 43	400/3/50	3.4	Off-cycle	150
TH-AH-036-23	Boxer-K44-36-AL	36000	4000	500	2 to 6	2320	30	38 to 43	400/3/50	5.3	Off-cycle	170
TH-AH-041-23	Boxer-K44-42-ALX	41000	4700	580	2 to 6	2700	30	38 to 43	400/3/50	5.8	Off-cycle	180
TH-AS-060-23	Hyper-H44-60-PPX	60000	7000	875	2 to 6	4065	30	38 to 43	400/3/50	7.6	Off-cycle	220
TH-AS-080-43	Hyper-H45-80-PPX	80000	9000	1125	2 to 6	5225	30	38 to 43	400/3/50	9	Off-cycle	250
TL-AH-005-41	Cuber-S2-05E-AL	5000	240	30	-16 to -18	85	-10	38 to 43	230/1/50	1.5	Electric	78
TL-ASH-007-43	Boxer-K23-07E-ALX	7000	800	100	-18 to -22	280	-10	38 to 43	400/3/50	2	Electric	85
TL-ASH-009-43	Boxer-K24-09E-ALX	9000	1200	150	-18 to -22	425	-10	38 to 43	400/3/50	2.6	Electric	88
TL-ASH-012-43	Boxer-K34-12E-AL	12000	1500	188	-18 to -22	525	-10	38 to 43	400/3/50	3.5	Electric	125
TL-ASH-016-43	Boxer-K43-17E-AL	15500	2000	250	-18 to -22	700	-10	38 to 43	400/3/50	4.3	Electric	150
TL-ASH-020-43	Boxer-K44-20E-ALX	20000	3000	375	-18 to -22	1050	-10	38 to 43	400/3/50	6	Electric	190

Basis of Design : (A) Loading will be 50 Kgs / Sq.ft. / day for Chiller room and 30 Kgs / Sq.ft. / day for Freezer room. (B) Door Openings : 3 to 5 / Hr. (C) Refrigerant : R22 / R407C / R404a / R134a for TH range and R-404a for TL range of equipment. (D) Supply Voltage : 200V - 240V for single phase while 380V - 440V for three-phase supply, otherwise use voltage stabiliser. (E) TH range offered for +22°C to +1°C is with Hermetic Danfoss / Emerson / Techemseh compressor, while TL range is offered for -1°C to -86°C with Hermetic Emerson for small capacities and Semi-Hermetic Bitzer / Dorin / Emerson compressors for higher capacities.

Trufrost reserves the right to change the specifications without prior notice

Coldrooms for a wide variety of applications

Hospitality



Commercial Kitchens



Dairy Products



Cloud Kitchens & Delivery



Fruits & Vegetables



Flight Kitchens



Bakery



Storage of Seafood





Ensuring freshness
of inflight meals

Flight Kitchens

Team Trufrost has the expertise to handle large hospitality projects such as air catering units and commissaries. Large flight kitchen projects executed by our team include flight kitchens for Taj Sats and Oberoi Flight Services in India and projects at Bahrain International Airport, Africa and the Middle East.





The Complete Project: from start to finish

Trufrost will support you right from conceptual design through to installation and beyond with quality workmanship and aftercare.

Site Survey

Upon receipt of your order, we conduct a full survey to grasp your requirements. It's the first step towards planning a cold room that meets your needs precisely by using the most appropriate equipment. Location of drains, floor recess, pipe routes and location of condensing units are very critical.

Project Management

A dedicated Project Manager will be assigned to support you from the moment you place your order, through to final completion. After carrying out a site survey, we will provide detailed approval drawings and point out site specific issues. Our team will then oversee the installation, through to final testing and commissioning.

Drawings

Our estimating team will then check if we have all the details we need. They will work with you directly and with any third party, such as a consultant, PMC or construction company. The plans can include manufacturing or CAD drawings with detailed specifications indicating how the finished cold room will fit into your existing operation.

Installation

Our installation teams consist of fully trained and qualified Panels installer and refrigeration engineers who are experienced in all aspects of commercial refrigeration system. A team will be assigned through the entire installation until completion.

Testing

This includes tasks such as carrying out a functional performance test, looking at energy efficiency and air circulation, and checking the components and the refrigeration systems.

Commissioning

Once a cold room is installed, our commissioning process ensures the overall operation meets with the original design specification before handing the system over for you to use. Trufrost team will run through a comprehensive commissioning checklist, including supplying a list of all the relevant component serial numbers, temperature and electrical readings etc.

Training

Training will also be given at this stage, to ensure your staff are familiar with operational, cleaning and day-to-day maintenance requirements.

Warranty and Aftercare

If you look after your cold room, it will serve you well for years. Refrigeration equipment must be maintained to prevent faults occurring. Appointing a good service and maintenance support will save you money through reduced energy bills, lower service costs and reduce downtime.



A vibrant, refreshing beverage is presented in a clear, faceted glass. The drink is filled with ice cubes, chunks of bright red watermelon, and slices of green lime. Fresh mint leaves are scattered throughout and used as a garnish. The glass sits on a light-colored wooden cutting board. In the background, a large slice of watermelon is visible, and another similar glass is slightly out of focus. The overall scene is set against a light green, textured background, suggesting a fresh and healthy summer drink.

Liven it up
with ice

Ice Machines

Trufrost Ice Machines are built around the Trufrost brand promise: best-in-class manufacturing, a wide variety of ice production & storage capacities and above all, reliability. Trufrost Ice Cube Machines and Flake Ice Machines come in capacities ranging from 18 kg to 1000 kg per day and are ideal for use in hotels, restaurants, fast food outlets, bars, coffee shops, clubs, convenience stores, healthcare applications and more.





Why invest in an ice machine?



Food safety

Today's demanding food service professionals recognize that ice is a food product and therefore needs to be accorded its due in terms of food safety. All that you need is a good quality water connection and our ice machines take care of the rest.



Simple to use and maintain

Trufrost Ice Maker is simple to use, easy to maintain and quite durable. Just connect your icemaker to a water inlet or insert a bottled water jar in specific models, turn the machine on, and you can begin to enjoy perfect ice within minutes. Highly energy efficient, they are designed to automatically turn off when the storage bin is full.



Savings

Those in the hospitality and food service business would know that buying ice is not only unreliable from a food safety perspective but also more expensive in the long run. Moreover, your sales and profits go up, the more ice you use in your cold beverages.

Types of Ice

Dice



- ❖ Beverages
- ❖ Cocktails
- ❖ Bagging
- ❖ Dispensing

Bullet Ice



- ❖ Soft Drinks

Granular Flakes



- ❖ Soft Drinks
- ❖ Food Display
- ❖ Healthcare
- ❖ Storage



Trufrost - The Smart Ice Machine

Trufrost ice machines come with a unique self-monitoring feature. The indicator lights in the control panel alert you when it is time to perform normal maintenance or call for service before it becomes an emergency. No wonder, Trufrost is today's most reliable and fool-proof ice system on the market.

Biggest ice cubes in the market

Size does matter when it comes to ice cubes as it directly reflects on its cooling efficiency. Most of the Trufrost ice machine models produce the largest cube sizes (please refer to the technical specifications table for the actual cube size).



Ice Makers with Built-In Storage Bin

Highly relevant for commercial outlets where space is at a premium, the self contained Trufrost Ice Machines present the best options for bars, coffee shops and restaurants and can also be used for undercounter applications.

- ◆ Contemporary, elegant design available in ice production capacities ranging from 18 to 95 kg per day.
- ◆ Insulated ice storage bin and door minimize air condensation and water formation.
- ◆ IC 18BW also comes with a cold water dispensing option
- ◆ IC 35BW & IC 50BW models have the option of accommodating a bottled water jar on top
- ◆ IC-35BWA, IC-50BWA & IC-100 models are suitable for undercounter applications.



IC-18BW

IC-35BW, IC-50BW

IC-100



Modular Ice Machines

Modular ice machines need separate storage bins. Trufrost modular ice machines come with a vertical evaporator and are specially designed for large scale usage in hotels, restaurants, bars and commercial sellers of ice cubes. They combine maximum energy yield whilst ensuring low investments and operating costs.

- ◆ Modular Ice Machines with high production capacity (190 to 900 kg per day).
- ◆ Low energy consumption
- ◆ Low water consumption per kg of ice produced
- ◆ Compatible Ice Storage Bins available separately at an extra cost.



IC-200
on ISB 105 / ISB 125 Bin



IC-300, IC-455
on ISB 125 / ISB 170 Bin



IC-900
on ISB 315 / ISB 350 Bin

Flake Ice

Flake ice is granular type of ice, perfect for display of fresh fish or for use by hotels for buffets for moisturising and cooling foodstuff to perfection. It is also perfect for use in research labs and bio-medical, life sciences and healthcare applications.



Flake Ice Machines with Built-In Storage Bin

Trufrost Flake Machines with self contained bins come in production capacities ranging from 20 - 200kg per day and are known for their low water and energy consumption.



IF-20



IF-50, IF-70



IF-120, IF-200



Modular Flake Ice Machines

Trufrost Modular Ice Flake Machines are available in production capacities of 300, 500 & 1000 kg per day and have a low water and energy consumption.



IF-300, IF-500
on ISB 220 Bin



IF-1000
on ISB 460 Bin





Ice Storage Bins

Trufrost Ice Storage Bins are perfectly insulated and specially designed to be compatible with Trufrost modular ice machines. They are made with special food grade material and come with an internal scoop holder that stays above ice line, enabling easy access and better sanitation.



ISB 105, ISB 125



ISB 125, ISB 170, ISB 220



ISB 315, ISB 350, ISB 460

Specifications - Storage Bins

Model	Ice Storage Capacity	Dimensions wxdxh (mm)	Compatible with
ISB-105 / ISB-125	105 kgs. / 125 kgs.	560*830*1150	IC-200
ISB-125 / ISB-170	125 kgs. / 170 kgs.	760*830*1150	IC-300, IC-455
ISB-125 / ISB-350	315 kgs. / 350 kgs.	1227*973*1255	IC-900
ISB-220	220 kgs.	760*830*820	IF-300, IF-500
ISB-460	460 kgs.	1220*930*910	IF-1000

Technical Specifications - Ice Machines



Model	Rated Capacity / 24 hrs.*	Ice Storage Capacity	Cube Shape / Size	Refrigerant	Power (w)	Dimensions wxdxh (mm)	Compatible Storage Bin
IC 18 BW	18 kgs.	2.2 kgs.	Bullet / Ø 35*39 mm	R134a	-	357*423*452	-
IC 35 BWA	30 kgs.	15 kgs.	Dice / 28*28*23 mm	R404a	280	500*450*830	-
IC 50 BWA	50 kgs.	18 kgs.	Dice / 28*28*23 mm	R404a	320	500*590*830	-
IC 100	98 kgs.	36 kgs.	Dice / 28*28*22 mm	R404a	580	660*685*920	-
IC 200	192 kgs	105 kg / 125 kg	Dice / 28*28*22 mm	R404a	1100	560*830*1718	ISB-105 / ISB-125
IC 300	318 kgs.	125 kg / 170 kg	Dice / 28*28*22 mm	R404a	1420	760*830*1718	ISB-125 / ISB-170
IC 455	455 kgs.	125 kg / 170 kg	Dice / 28*28*22 mm	R404a	2300	760*830*1893	ISB-125 / ISB-170
IC 900	910 kgs.	315 kg / 350 kg	Dice / 28*28*22 mm	R404a	3800	1227*973*2048	ISB-315 / ISB-350
IF 20	20 kgs.	10 kgs.	Granular Flakes	R 134a	280	330*470*605	-
IF 50	50 kgs.	15 kgs.	Granular Flakes	R 134a	380	400*540*700	-
IF 70	70 kgs.	25 kgs.	Granular Flakes	R 134a	460	400*510*845	-
IF 120	120 kgs.	40 kgs.	Granular Flakes	R 134a	550	500*611*950	-
IF 200	200 kgs.	60 kg	Granular Flakes	R134a	1040	650*740*1100	-
IF 300	300 kgs.	220 kg	Granular Flakes	R404a	1400	760*830*178	ISB 220
IF 500	500 kgs.	220 kg	Granular Flakes	R404a	2400	760*830*1890	ISB 220
IF 1000	1000 kgs.	460 kg	Granular Flakes	R404a	3500	1220*930*2060	ISB 460

* At 10°C incoming water and 10°C air temperature Electricals: 220V/50Hz./Single Phase
 Height & width for IC 200/300/455/900 and IF 300/500/1000 is with the suggested storage bin
 Specifications are subject to change without prior notice due to continuous product development





Butler, a brand that truly complements Trufrost refrigeration solutions



Cooking solutions
par excellence

Turn gourmet cooking
into a child's play



Combi Steamers for Gastronomy & Pastry

Butler professional combi steamers bring an amazing reliability consistency and sturdiness at a chef's service through the use of an authentic Made in Italy product. Ovens with direct steam injection are available from 7 to 20 levels (GN 1/1 and EN) with Analog or Touch screen controls. They come in electric and gas variants with crosswise insertion of the trays, meant for chefs who expect the optimal performances both in gastronomy and pastry cooking. Butler combi steamers help you achieve perfectly even cooking results on every tray, at any level. More importantly, they don't burn a hole in your pocket.



ECS-020A, ECS-020T,
GCS-020A, GCS-020T



ECS-012A, ECS-012T,
GCS-012A, GCS-012T



ECS-007A, ECS-007T, ECS-007TM,
GCS-007A, GCS-007T, GCS-007TM



ECS-004A



ECS-004T

Compact Combi Steamers

Butler Professional Compact Combi Steamers combine compactness and performance. With their 51 cm width, these compact ovens will find space in every kitchen. Convenient also as support ovens, they can accommodate 4 trays of GN 2/3, with touch screen or analogic control panel options. With the cooking chamber moulded with rounded corners and fans made of stainless steel, they come with an autoreverse ventilation system with two speeds to ensure better cooking uniformity. They also feature a steam release valve with manual or automatic control and the drip-pan is connected to the drain.

- ◆ Professional Compact ovens are stackable on top of each other, so that you can fully exploit the precious space in your kitchen.
- ◆ With the ergonomic door handle with patented design you can open the oven even with your hands occupied, from both sides.
- ◆ Operable on single phase 220V electricals.
- ◆ Door opening direction reversible on site even after installation.





Distinguishing features of Butler Combi Steamers

- ◆ Control panels: Simple, efficient and intuitive controls. Possibility to choose between Analog controls, Touch Screen and Multi Level Cooking
- ◆ Ergonomic door hand with opening from both sides and double snap safety lock (optional)
- ◆ Cooking chamber molded cavity in stainless steel AISI 304 with rounded corners
- ◆ Steam release valve: manual or automatic control
- ◆ Spotless chamber washing (with Touch Control Panel & Multi Level Cooking models)
- ◆ Tray holders to fit both GN 1/1 and EN trays
- ◆ Well-lit interiors
- ◆ Pitch: 67 mm

Analog Control Panel

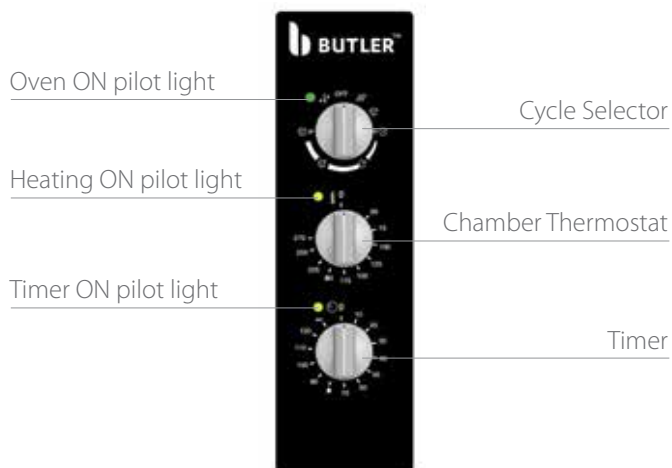

Touch Screen Control Panel

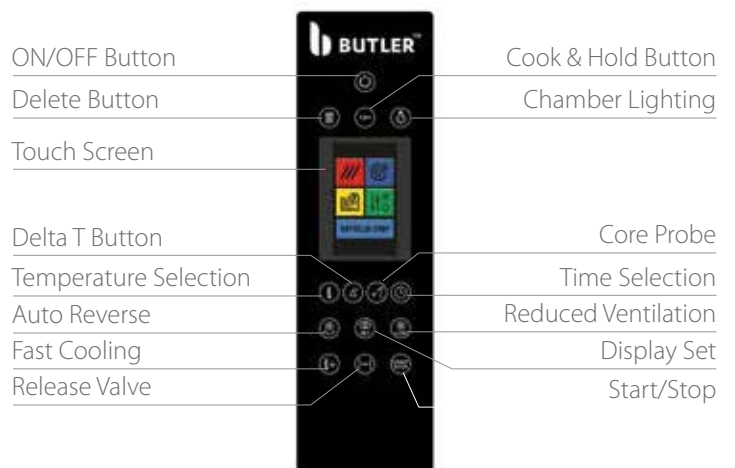

Multi Level Cooking

This feature on models ECS-007TM and GCS-007TM optimises food production during mise en place and is really handy for à la carte cooking. It allows for effective cooking of mix loads, thereby offering flexibility and speedy response. You can use each rack individually for production, increase utilisation through the use of clever mixed loads and save on both - time and energy.

Advance Washing System

Cooling System

Preheating



Manual Operation

Pre-programmed Recipes

Multi Level Cooking

Control Panel Specifications

Oven Model	With Analog	With Touch Control
Convection with Ventilation	50-270°C	20-270°C
Combi with Direct Steam	50-270°C	20-270°C
Steam	50-100°C	20-100°C
Autoreverse	Standard	Standard
Double Ventilation speed	Standard	Standard
Core Probe	Not Available	Standard
Delta T	Not Available	Standard
Automatic Programs	Not Available	300 programs 6 phases
Automatic preheating	Not Available	Standard
USB connection	Not Available	Standard
Automatic washing	Not Available	Standard with Liquid detergent



Programs: Recipes

The intuitive graphic interface is designed to support the chef in the choice of the recipes desired. The models with Touch Control panel come with six preloaded folders, where you will find creative preparations for meat, fish and vegetable dishes, pastry and regeneration.

Vegetables

Vegetables fresh, crisp and colourful. Fresh vegetables are cooked gently, and ensure that vitamins, nutrients and colours are preserved.



Gratins, pizzas & snacks

Churns out an incredible variety of pizzas – super moist on the top, crispy on the borders and delicious at the core. It is equally easy to cook delicious pasta, rice and idlis to suit the local palate.



Desserts & cakes

Incredibly multifunctional – perfect for preparing desserts. Whether you bake cakes or poach pears in red wine, it's ingenious: with the 2 in1 combination you can bake on one shelf and poach on another at the same time.



All kinds of bread

Scores of baguettes can be baked at the same time in a Butler combi. The special auto-reverse feature ensures that all bakery items turn out absolutely even, from the top to the bottom shelf.



Fish, meat & kebabs

Cooks fish, meat and vegetables at the same time - with no aroma transfer.



Grill & pan fry

Grill scores of cutlets in minutes. Juicy steaks get a delicious barbecue look.



Technical Specifications



Model	Power	Voltage	Gas Power	Gas Consumption	GN/EN* Trays	Pitch	Dimensions W x D x H (mm)	Control Panel	Weight
ECS-004A	3.0Kw	220V 1N/50Hz#	-	-	4 x 2/3	67mm	510 x 660 x 670	Analog	-
ECS-004T	3.0Kw	220V 1N/50Hz#	-	-	4 x 2/3	67mm	510 x 660 x 670	Touch Screen	-
ECS-007A	11.5Kw	400V 3N/50Hz	-	-	7 x 1/1	67mm	920 x 730 x 900	Analog	105kgs
ECS-007T	12.3Kw	400V 3N/50Hz	-	-	7 x 1/1	67mm	950 x 790 x 870	Touch Screen	123kgs
ECS-007TM	12.3Kw	400V 3N/50Hz	-	-	7 x 1/1	67mm	950 x 790 x 870	Touch Screen	123kgs
ECS-012A	17.3Kw	400V 3N/50Hz	-	-	12 x 1/1	67mm	920 x 730 x 1230	Analog	128kgs
ECS-012T	16.9Kw	400V 3N/50Hz	-	-	12 x 1/1	67mm	950 x 790 x 1190	Touch Screen	150kgs
ECS-012TM	18.4Kw	400V 3N/50Hz	-	-	12 x 1/1	67mm	840 x 996 x 1275	Touch Screen	150kgs
ECS-020A	30 kW	400V 3N/50Hz	-	-	20 x 1/1	67mm	970 x 1030 x 1880	Analog	390kgs
ECS-020T	30 kW	400V 3N/50Hz	-	-	20 x 1/1	67mm	970 x 1030 x 1880	Touch Screen	390kgs
ECS-020TM	36 kW	400V 3N/50Hz	-	-	20 x 1/1	67mm	860 x 998 x 1860	Touch Screen	220kgs
ECS-202T	52 kW	400V 3N/50Hz	-	-	20 x 2/1	67mm	966 x 1422 x 1880	Touch Screen	450kgs
GCS-007A	0.3Kw	230V 1N/50Hz	14.5Kw	1.143 Kg/hr	7 x 1/1	67mm	920 x 790 x 900	Analog	116kgs
GCS-007T	0.6Kw	230V 1N/50Hz	14.5Kw	1.143 Kg/hr	7 x 1/1	67mm	950 x 790 x 870	Touch Screen	137kgs
GCS-007TM	0.6Kw	230V 1N/50Hz	14.5Kw	1.143 Kg/hr	7 x 1/1	67mm	950 x 790 x 870	Touch Screen	137kgs
GCS-012A	0.5Kw	230V 1N/50Hz	20.5Kw	1.617 Kg/hr	12 x 1/1	67mm	920 x 790 x 1250	Analog	145kgs
GCS-012T	0.6Kw	230V 1N/50Hz	20.5Kw	1.617 Kg/hr	12 x 1/1	67mm	950 x 790 x 1190	Touch Screen	192kgs
GCS-012TM	0.6Kw	230V 1N/50Hz	20.0Kw	1.617 Kg/hr	12 x 1/1	67mm	840 x 1026 x 1294	Touch Screen	192kgs
GCS-020A	1.5 kW	230V 1N/50Hz	29 kW	-	20 x 1/1	67mm	966 x 1086 x 1886	Analog	360kgs
GCS-020T	1.5 kW	230V 1N/50Hz	29 kW	-	20 x 1/1	67mm	966 x 1086 x 1886	Touch Screen	360kgs
GCS-020TM	1.5 kW	230V 1N/50Hz	29 kW	-	20 x 1/1	67mm	970 x 1030 x 1880	Touch Screen	360kgs

Specifications are subject to change without prior notice due to continuous product development

*GN 1/1 Tray (530 x 325mm), EN Tray (600 x 400mm), GN 2/3 Tray (354x325mm)

Also available with 400V 3N/50Hz





Building safer, cooler
& greener kitchens



Induction: the future of cooking



Commercial Induction Systems

Butler's innovative commercial induction systems are designed to take the food service experience to a whole new level with an advanced range of induction warmers, cooktops, woks, built in induction trolleys and fryers. Professional chefs in commercial kitchens can now enjoy enhanced productivity through faster cooking, substantial energy savings but most of all, a cooler and safer kitchen.

Working Principle of Induction Systems

Induction cooking uses electric currents to directly heat pots and pans through magnetic induction. Instead of using thermal conduction (a gas or electric element transferring heat from a burner to a pot or pan), induction heats the cooking vessel itself almost instantly.

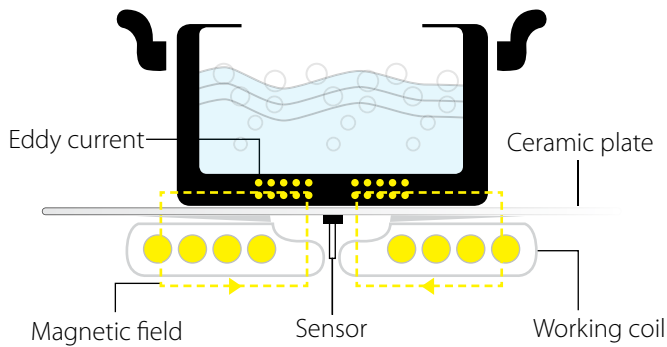
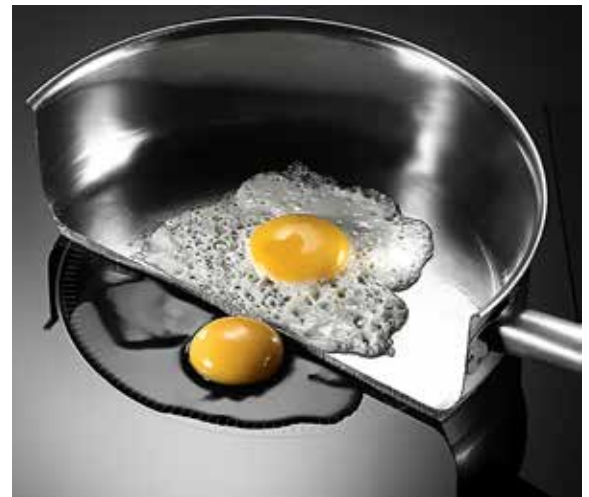

Induction heating uses electromagnetic energy to heat cookware made of magnetic material such as stainless steel, iron, nickel or various alloys. The coils produce a high frequency alternating magnetic field when turned on, ultimately flowing through the cookware. The metal molecules are attracted in different directions as the current alternates, causing the cookware to become hot. Since the cooktop's glass ceramic surface contains no magnetic material, it is unaffected by the magnetic field.

Voltage stabilizer is highly recommended for all induction equipment to avoid damage due to power fluctuation.

% Energy Delivered to Pan

Butler induction systems are 90% efficient, meaning that 90% of the energy consumed is delivered to the pan. This is unmatched by gas (typically 40%) or traditional electrically powered cooking devices (typically 50%).

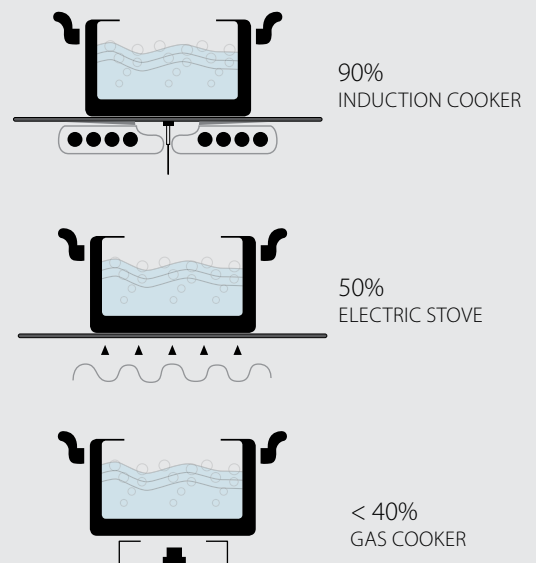

Benefits of Induction Cooking

Induction cooking devices release less heat into the room, use less fuel, and finally, you can enjoy a cleaner, safer, cooler, and more efficient kitchen, with lower energy bills.



Faster



Safer



Energy Saving



Easy to Clean



Cooler

A close-up photograph of a stainless steel cooking pot. The pot has a brushed metal finish and a handle on the left side. A white, rectangular tag is pinned to the side of the pot with a blue pushpin. The tag contains text in blue font.

Use a
magnet to
find out
if your
pots and
pans
are
induction
ready!

Choose your objective

Built for the diverse demands of commercial foodservice, Butler Induction offers a variety of warming and cooking solutions for wide ranging applications such as buffets, cafeterias, catering, restaurants etc. Keep hot foods hot and flavourful with Butler Induction Warmers. Or use Butler Induction Cooking Hobs & Woks to boil, simmer, sear, sauté and even reheat to absolute perfection!

WARMING

or

COOKING



CIW-1.0
DIW-1.0



CIH-3.5
CIW-3.5
CIH-5.0
CIW-5.0



DIH-3.5 (New)
DIW-3.5



Choose your usage

Butler Induction offers versatile options for front as well as back of the house. Choose from countertop models that are conveniently portable and can be moved around from one location or application to another, be that onsite catering or a made-to-order cook station or hectic buffet service. Or choose our Drop-In warming or cooking solutions and make them a fully integrated part of any stylish foodservice operation and design.

COUNTER TOP

DROP-IN

WARMING



CIW-1.0



DIW-1.0

COOKING



CIH-3.5



CIH-5.0



CIW-3.5



CIW-5.0



DIH-3.5 (New)



DIW-3.5

Choose your power

Choose from a variety of power levels, ranging from 250 to 5,000 watts. The higher the power level, the less time it will take to complete a warming or cooking task. Just make sure you have the right amount of voltage to support your need for speed.

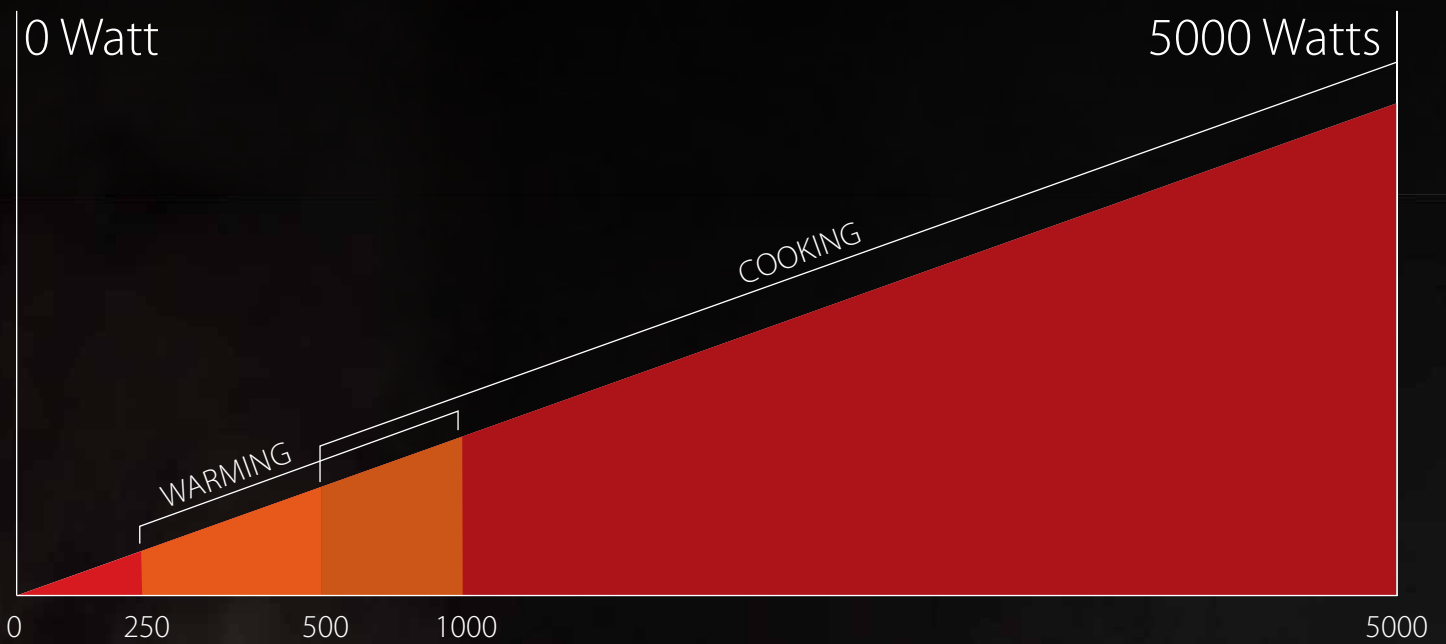



Countertop Induction Warming Trays

These portable induction warming and holding trays from Butler keep food at the right temperature while improving your presentation and overall quality. No flames or hot surfaces provide for a safer, cooler kitchen making it ideal for catering as well as buffet applications.



CIW-1.0

CE

- ◆ Glass hob
- ◆ Stainless steel body with two stainless steel handles
- ◆ Power regulation knob
- ◆ Temperature display on the right corner of the glassplate
- ◆ Electronic overheating protection

Drop in Induction Warmers

Butler drop in induction warming and holding systems keep food at the right temperature while improving your presentation and overall quality and are ideal for catering application as well as buffet restaurants. No flames or hot surfaces provide for a safer, cooler kitchen. They are a boon for modern day buffets making the food warming more attractive, safe and free of odours caused by burners.



- ◆ Glass hob
- ◆ Stainless steel body
- ◆ Power regulation knob
- ◆ Temperature display on the right corner of the glassplate
- ◆ Electronic overheating protection



DIW-1.0

CE

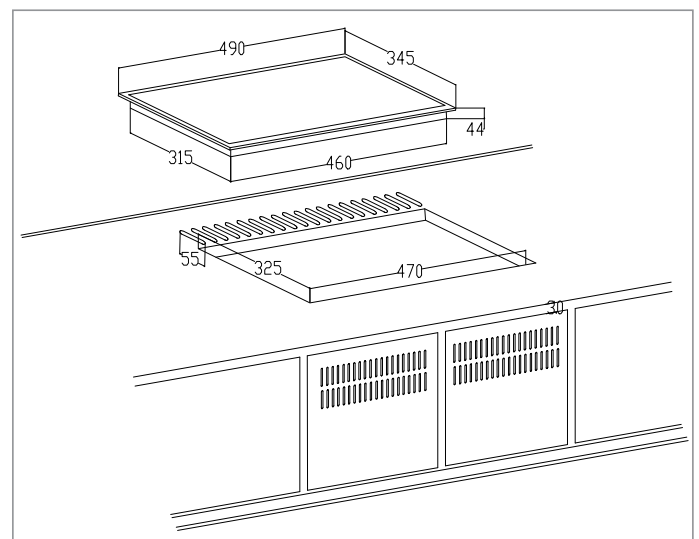

Cut-out

Technical Specifications

CE

Model	Voltage	Power	Temperature Range	Dimensions (wxdxh)	Cut-out Dimensions (wxd)
CIW-1.0	220-240V/50Hz	1000W	40°C - 100°C	530 x 335 x 61mm	-
DIW-1.0	220-240V/50Hz	1000W	40°C - 100°C	490 x 345 x 60.5mm	470 x 325mm

Specifications are subject to change without prior notice



Induction Cookware

Not all pieces of cookware can be used on induction cooktops. Cookware made from aluminum, copper or glass, including Pyrex will not work on its own. Induction cookware must be made with a magnetic-based material, such as cast iron or magnetic stainless steel. To check if your pans will work, hold a magnet next to the pan base; if it attracts, the pan will work on induction.





Countertop Induction Hobs & Woks

Butler portable cooktops & countertop woks heat food evenly, quickly, and efficiently, with easy-to-clean surfaces and energy efficient technology. They are designed for medium to heavy duty cooking needs and can be placed on kitchen counters for both - back of the house and interactive cooking applications. No flames or hot surfaces provide for a safer, cooler kitchen. They come in 3.5KW (220V/ Single phase) and 5KW (380 V/ 3 Phase) variants.

Key Features

- ◆ Glass hob/wok
- ◆ Stainless steel body
- ◆ Touch control
- ◆ Timer, LED display (0-180 minute)
- ◆ Electronic overheating protection



CIH-3.5

CIW-3.5

CIH 5.0

CIW-5.0

Technical Specifications



Model	Voltage	Power	Temperature Range	Dimensions (wxdxh)	Power Levels	Temperature Setting	Utensil Size
CIH-3.5	220 / 50Hz / 1Ph	3500W	60°C - 240°C	425 x 330 x 105mm	500-3500W (1-10)	1 - 10	120-360mm
CIW-3.5	220 / 50Hz / 1Ph	3500W	60°C - 240°C	425 x 340 x 135mm	500-3500W (1-10)	1 - 10	120-360mm
CIH-5.0	380V / 50Hz / 3Ph	5000W	60°C - 240°C	398 x 515 x 168mm	500-5000W (1-10)	1 - 15	120-400mm
CIW-5.0	380V/50Hz / 3Ph	5000W	60°C - 240°C	398 x 515 x 183mm	500-5000W (1-10)	1 - 15	120-400mm

Specifications are subject to change without prior notice

Drop in Induction Hobs & Woks

Butler drop-in cooktops & drop-in woks snugly fit in your kitchen counters and heat food evenly, quickly, efficiently, and are easy-to-clean. They are great for show kitchens and are designed to handle heavy duty usage. No flames or hot surfaces provide for a safer, cooler kitchen.

Key Features

- ◆ Glass hob/wok
- ◆ Stainless steel body
- ◆ Power regulation by touch control
- ◆ 1-10 power levels (500 - 3500W)
- ◆ 1-10 temperature setting



DIH-3.5



DIW-3.5

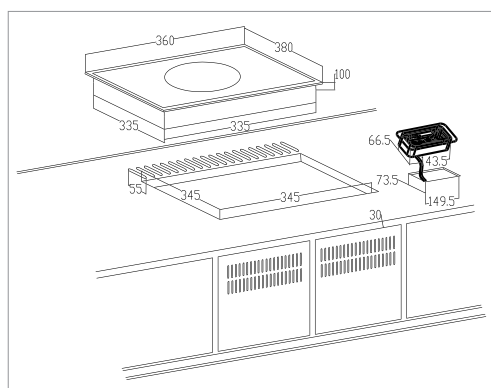

Cut-out

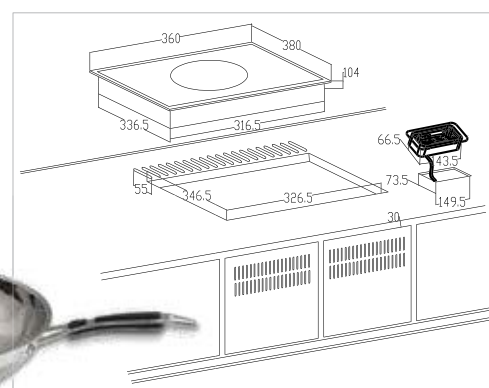

Cut-out

Technical Specifications



Model	Voltage	Power	Temperature Range	Dimensions (wxdxh)	Cut-out Dimensions (wxd)
DIH-3.5	220-240V/50Hz	3500W	60°C - 240°C	360 x 380 x 120mm	345 x 345mm
DIW-3.5	220-240V/50Hz	3500W	60°C - 240°C	360 x 380 x 120mm	346.5 x 326.5mm

Specifications are subject to change without prior notice

The science behind good food



How to choose the best commercial pizza oven for your business?

Selecting the right pizza oven is essential to starting your pizzeria. From cloud kitchen and large commercial operations to hole-in-the-wall family-owned businesses, what may be appropriate for one setting may not work for a different kind of establishment. Be sure to take the time and research the various pizza oven options available and choose the one that best fits your requirements. Keep in mind the number and size of pizzas you expect to make per day, the fuel source and the space you have for your oven. Also keep in mind which type of oven will bring out the distinctive flavours of your pizza to the fullest. Budget might also be a concern, but try not to skimp on your pizza oven, as it is the very foundation of your pizza business.

Gas vs. Electric Pizza Ovens

Conveyor or deck ovens are all available with either gas or electric hookups. However there are some slight differences between gas pizza ovens and those that run on electric. Working with a gas oven is best for the high-volume, traditional pizza maker. These units will produce a crispier crust and cook the rest of your pizza evenly. But what it all really boils down to is what utility your establishment has available. If your business doesn't have access to natural gas or liquid propane, then the electric models will better suit your needs.

Application

Suggested Oven Type

HEAVY DUTY

Conveyorised Hot Air Impingement Ovens

MEDIUM DUTY

Conveyorised Hot Air Impingement Ovens

LOW TO MEDIUM DUTY

Stone Deck Ovens

LIGHT DUTY

Small Stone Deck Ovens

Expected pizza output

The primary driver of which pizza oven to opt for comes from the pizza output expected by any eatery.



Multi-Purpose Conveyorised Impingement Ovens

Butler Hot Air Conveyorised Impingement Ovens are designed to cook a variety of products including pizzas, bagels, garlic breads, omelettes, sea food and ethnic Indian foods like naans, crisp rotis, kebabs and more.

What is impingement technology?

Impingement technology uses hot air to be directed at the cooked products from the top and bottom through specially designed "pores" that form columns of air moving the heat aerodynamically at a high speed. This hot air penetrates the surface moisture barrier of the product transferring heat and engulfing the product to retain its moisture.

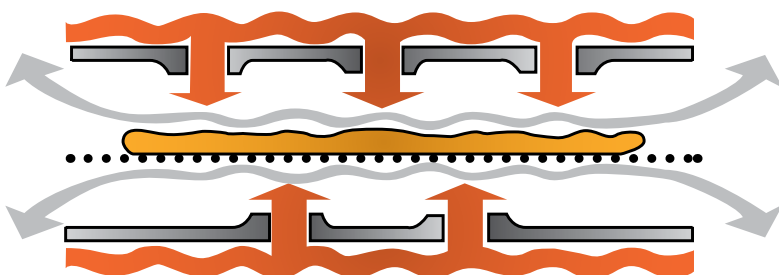

400 mm (15.7")
belt width

520 mm (20.5")
belt width

800 mm (31.5")
belt width



Gusto

Conveyorised Hot Air Impingement Ovens

The Butler Gusto Hot Air Conveyor Ovens bake faster and at a lower temperature than other ovens. Hot air moves the heat aerodynamically instead of using high temperatures. The streams of hot air remove the surrounding layers of cool heavy air around the foodstuff. Gusto ovens are designed to cook a wide range of products including pizza, breads, sandwiches, bagels, naans, sea food and more. They offer a premier countertop or a floor standing cooking platform for cloud kitchens, busy pizzerias and restaurants. Available in a choice of electric and gas versions, they utilise a choice of conveyor belt widths from 400 mm to 800mm.



Gusto 800G Max

Conveyorised Impingement Ovens

This heavy duty hot air impingement oven from Butler comes with a 800mm wide belt and a 940 mm x 800 mm baking chamber and can bake large pizzas or 3 x 9" pizzas placed side by side. The oven is also designed to cook a variety of other products including bagels, garlic breads, omelettes, sea food and ethnic Indian foods like naans, crisp rotis, kebabs and more.



Gusto 800G Max

Standard Features

- ◆ Available in PNG or LPG model
- ◆ Electricity: 220V, 50/60 HZ, 300 watts
- ◆ Gas consumption: LPG 1.10 m³/h, PNG 2.60 m³/h
- ◆ Conveyor belt width: 800 mm
- ◆ Heating zone (heating chamber) length: 940 mm
- ◆ Oven dimension: 1800 mm x 1570mm x 600mm
- ◆ Net weight of single oven:396 kg
- ◆ Maximum operating temperature: 300°C (230°C is recommended)
- ◆ Warm up time: 6-8minutes
- ◆ Baking time: 5 – 6 minutes at 230°C

Optional

- ◆ Stand with casters

Cleanability

- ◆ Butler Gusto Ovens are designed for easy cleaning. Removable parts include: crumb pans, end panels, air fingers, exit tray, and a removable conveyor belt assembly.

Ventilation

- ◆ Use of a ventilation hood is recommended.

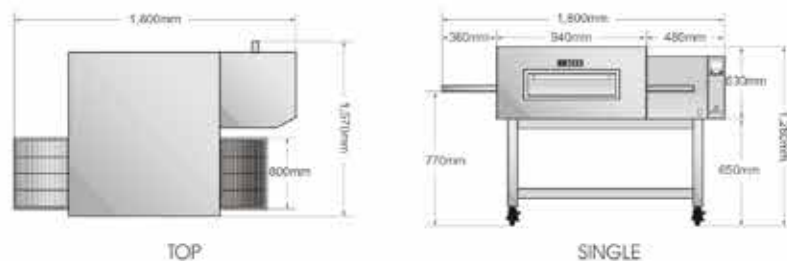



Gusto 520

Conveyorised Impingement Ovens

These heavy duty hot air impingement ovens from Butler come with a 520mm wide belt and a 710 mm x 520 mm baking chamber and can bake large pizzas or 2 x 9" pizzas placed side by side. Available in gas or electric options. These ovens are also designed to cook a variety of other products including bagels, garlic breads, omelettes, sea food and ethnic Indian foods like naans, crisp rotis, kebabs and more.



Gusto 520G
Gusto 520E



Standard Features

- ◆ Maximum operating temperature: 300°C (230°C is recommended)
- ◆ Short set-up time: (Gas: 6~8 mins under set temp. 230°C; under preheat condition, only 3 minutes. Electric:: 10~20 / 5-7minutes)
- ◆ Reduced gas consumption and increased cooking efficiency
- ◆ Low noise
- ◆ 28" (710mm) long cooking chamber with 20.5" (520 mm) belt
- ◆ 57" (1445mm) long, 39" (1000mm) deep, and 19" (480mm) high overall dimensions
- ◆ Furnished with 4" legs
- ◆ Stackable up to three high
- ◆ Microprocessor-controlled bake time/conveyor speed
- ◆ Stainless steel front, sides, top and interior
- ◆ Reversible conveyor direction
- ◆ Energy saving standby mode (gas)
- ◆ 2 conveyor end stops
- ◆ 2 crumb pans

Optional

- ◆ Stand with casters

Cleanability

- ◆ Butler Gusto Ovens are designed for easy cleaning. Removable parts include: crumb pans, end panels, air fingers, exit tray, and a removable conveyor belt assembly.

Ventilation

- ◆ Use of a ventilation hood is recommended.

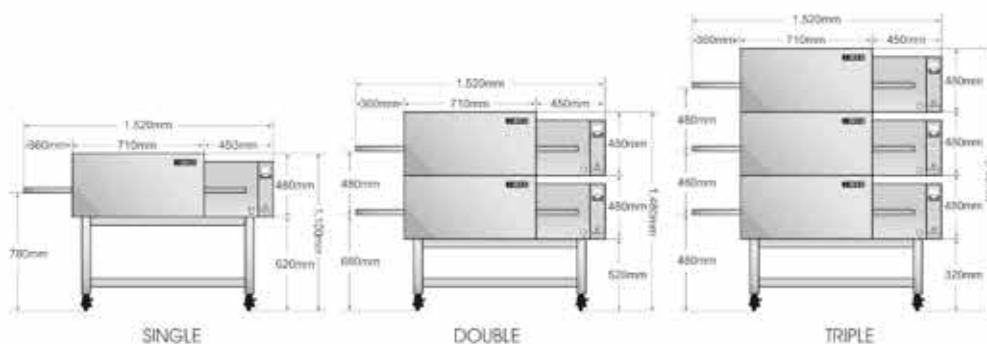

Gusto 400E/ Gusto 400G

The Countertop Impingers

This countertop impinger from Butler comes with a 400mm wide belt and a 460 mm x 400 mm baking chamber and can bake upto 15.7" pizzas. The oven can be made to run either on 240V/ single phase or 380V/3 phase electricals. The oven is also designed to cook a variety of other products including bagels, garlic breads, omelettes, sea food and ethnic Indian foods like naans, crisp rotis, kebabs and more.



Gusto 400E/ Gusto 400G

Standard Features

- ◆ Maximum operating temperature: 300°C (230°C is recommended)
- ◆ Short set-up time: (10-12 mins to set temp. 230°C) under preheat condition, only 5-7 mins
- ◆ Low noise
- ◆ 460 mm long cooking chamber with 400 mm belt
- ◆ 1065mm long, 850mm deep, and 450mm high overall dimensions
- ◆ Furnished with 4" legs
- ◆ Stackable up to three high
- ◆ Microprocessor-controlled bake time/conveyor speed
- ◆ Stainless steel front, sides, top and interior
- ◆ Reversible conveyor direction
- ◆ Energy saving standby mode
- ◆ 2 conveyor end stops
- ◆ 2 crumb pans

Optional

- ◆ Stand with casters

Cleanability

- ◆ Butler Gusto Ovens are designed for easy cleaning. Removable parts include: crumb pans, end panels, air fingers, exit tray, and a removable conveyor belt assembly.

Ventilation

- ◆ Use of a ventilation hood is recommended.

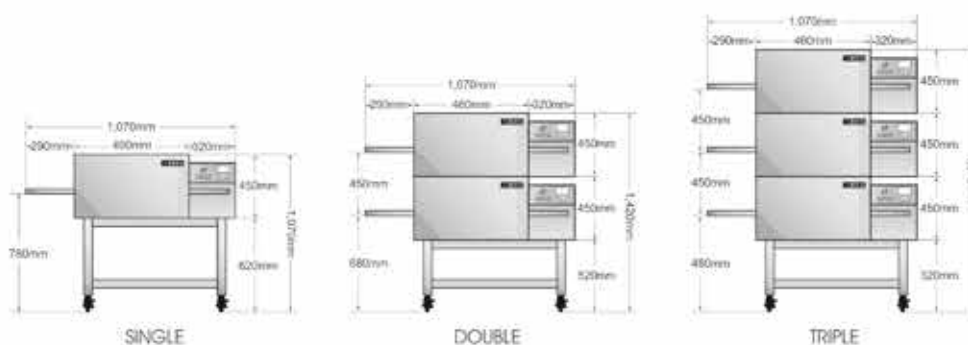



Technical Specifications - Gusto Hot Air Conveyor Pizza Ovens

Model	Gas	Input Electricity	Gas Pressure (kpa)	Gas Consumption (m ³ /hr)	Dimension L*W*H (MM)	Volume (M ³)	Conveyor size (MM)	Calorie (Kcal/h)	Baking Chamber Length (MM)	Output pcs (9" pizza)	Net (KG)
GUSTO 800G Max	LPG	220V	2.3-3.3	1.10 m ³ /h	1800 x 1570 x 600	1.64	1700*800	26000	910 x 800	180/hr	396
	PNG	50/60Hz	1.0-2.5	2.60 m ³ /h							
GUSTO 520G	LPG	220V	2.3-3.3	0.42 m ³ /h	1520*1140*480	0.83	1445*520	10000	710 x 520	70/hr	146
	PNG	50/60Hz	1.0-2.5	0.95 m ³ /h							
GUSTO 400G	LPG	220V	2.3-3.3	0.31	1070*850*450	0.39	1055*400	7300	460 x 400	20/hr	106
	PNG	50/60Hz	1.0-2.5	0.7 m ³ /h							



Model	Input Electricity	Electric Power Output (KW)	Power Consumption (KWH)	Dimension L*W*H (MM)	Volume (M ³)	Conveyor size (MM)	Calorie (Kcal/h)	Baking Chamber Length (MM)	Output pcs (9" pizza)	Net (KG)
GUSTO 520E	380V/50Hz/3Ph	11.5	7.5	1520*1140*480	0.83	1445*520	10000	710 x 520	70/hr	146
GUSTO 400E	220V/50Hz/1Ph*	6.8	4.0	1065*850*450	0.39	1055*400	7300	460 x 400	20/hr	106

Maximum operating temperature: 300°C (230°C is recommended)
 *Same oven can also be made to operate on 380V/50Hz/3Ph

Specifications are subject to change without prior notice due to continuous product development

Recommended Stands

Model	Dimensions (L x W x H) MM	Applicable Models	Casters	Material Used	Net Weight (KG)
GS-800	1460*940*650	Gusto 800G and Gusto 800E	6	Stainless Steel	-
GS 520	780*880*630	Gusto 520G and Gusto 520E	4	Stainless Steel	13
GS 400	710*510*630	Gusto 400G and Gusto 400E	4	Stainless Steel	12



Pizza Stone Ovens

Butler pizza stone ovens are designed to churn out great tasting pizzas with amazing consistency. You can choose between 3 electric models (EPO series) and one gas operated model (GPO series).

- ◆ All stainless steel body
- ◆ High quality pizza stone accommodates upto 4 pizzas (EPO-36 Premia & GPO-36 Premia only)
- ◆ Temperature control allows users to set any constant temperature for baking pizzas
- ◆ A peep-in window offers a view of the pizzas while being baked
- ◆ Insulated chamber



EPO-1D Touch



EPO-2D Touch



EPO-1D, EPO-2D



EPO-36 Premia DT, GPO-36 Premia

Technical Specifications



Model	Power	Electricals	Temperature Range	Dimensions W x D x H (mm)	Stone Dimension W x D x H (mm)	Cavity Dimension W x D x H (mm)	Weight
EPO-1D Touch	2kW	220 - 240V/50Hz	0-350°C	560x570x280	400x400x15	400x400x120	19kg
EPO-2D Touch	3kW	220 - 240V/50Hz	0-350°C	560x570x440	400x400x15	400x400x120	29kg
EPO-1D	2kW	220 - 240V/50Hz	0-350°C	560x570x280	400x400x15	410x410x120	24kg
EPO-2D	3kW	220 - 240V/50Hz	0-350°C	560x570x440	400x400x15	410x410x120	33kg
EPO-36 Premia DT	4.8kW	220 - 240V/50Hz	20-400°C	925x570x430	645x480x15	640x470x180	38.5kg
GPO-36 Premia*	48W	220 - 240V/50Hz	20-400°C	1000x750x550	620x520x15	650x570x180	68kg

*Gas Consumption: 0.24kg/hr

Specifications are subject to change without prior notice due to continuous product development



Little Master



Portable Gas Based Mini Pizza Ovens

The Little Master from Butler is a delightful range of gas based Mini Pizza Stone Ovens. These are designed to churn out great tasting pizzas with amazing consistency. The pizza stone heats up and holds high temperatures. When the pizza is placed on the stone, the crust begins to cook immediately, much like the cooking style of a traditional brick oven.

- ◆ All stainless steel body
- ◆ High quality pizza stone
- ◆ Simple temperature control allows users to set a constant temperature
- ◆ Lifiable lid
- ◆ Temperature range from 0 - 350°C



Technical Specifications



Model	Rated Input Power	Temperature Range	Dimensions W x D x H (mm)	Pizza Stone Dimension (mm)	Cooking Grill Dimension (mm)	Weight
Little Master	20000 BTU	0-350°C	685x560x400	330 x 330 Ø	520x330	16kg

Specifications are subject to change without prior notice due to continuous product development

Floor Standing Fryers

These American style floor standing fryers from Butler come in two variants - electric and gas and are ideal for quickly frying chicken, fish, french fries, onion rings and more. The gas based Wonderfry - 3BG (FGF-300) comes with 3 tubes and Wonderfry-4BG (FGF-400) is designed with 4 tubes. They come with a single tank and two baskets so does the electric model Wonderfry 21.2E. The Wonderfry - 16.2E is also an electric fryer with 2 baskets & 2 x 16 litre tanks. The fryer tanks are tested for leakage to ensure safety.

- ◆ Thermo-tube design
- ◆ Stainless steel frypot, front door/s, and backslash
- ◆ Wire form basket hanger and 2 fry baskets in both models
- ◆ Adjustable steel legs



Wonderfry - 3BG,
Wonderfry - 4BG



Wonderfry - 16.2E
Wonderfry - 21.2E

Technical Specifications



Model	Voltage	Power	Gas Input Capacity	No. of Tanks	Each Tank Size	No. of Baskets	Dimensions (wxdxh)	Frybasket Dimensions (wxdxh)
WONDERFRY - 3BG	220V/50Hz	-	90,000 Btu/hr	1	18-20.5 Litres	2	394x760x885 mm	170x335x280 mm
WONDERFRY - 4BG	220V/50Hz	-	120,000 Btu/hr	1	22-25 Litres	2	394x760x885 mm	170x335x280 mm
WONDERFRY - 16.2E	380V/50Hz	5 + 5KW	-	2	16 + 16 Litres	2	740x550x910 mm	230x250x120 mm
WONDERFRY - 21.2E	380V/50Hz	5 + 5KW	-	1	21 Litres	2	420x830x1080 mm	360x420x270 mm

Specifications are subject to change without prior notice due to continuous product development





OFC-1

Oil Filtration Cart

The most expensive aspect of offering fried foods is the amount you spend on oil. Butler Oil Filtration Carts extend the life of the oil you use. They are designed for portable filtering for all your frying appliances. These portable filters have the ability to receive oil gravity drained from fryers and come with 4 castors, a crumbs collection basket and a pump that transports the filtered oil back to the frypot.

Key Features:

- ◆ Four swivel casters allow for easy movement and storage of the filter.
- ◆ Quick disconnect hose connections make it easy to assemble and disassemble.
- ◆ Low profile allows for easy placement under the fryer drain.
- ◆ Easy to remove filter assembly.
- ◆ Lift out filter pan for easy cleaning.



Technical Specifications



Model	Voltage	Power	Tank Capacity	Pumps per minute	Dimensions (wxdxh)	Tank Height	Hose with Nozzle	Casters
OFC-1	220V/50Hz	550W	50L	15 L	440x755x620 mm	235 mm	5 Feet	4

Specifications are subject to change without prior notice due to continuous product development

Countertop Fryers with Auto Lift

The EF-12 Auto is an advanced professional fryer from Butler that comes with a specially designed feature that allows the fry-basket to automatically lift up above the oil level once the frying cycle is complete. This feature also facilitates the surplus oil to be drained back from the fry-basket to the oil tank. It comes with computerised touch controls giving complete freedom to the operators to multi task during the frying cycles whilst ensuring consistency of the food being cooked.

This sensational product is particularly suited for fast food restaurants. Suitable for frying chips, chicken, fish, onion rings and more in quick succession using minimal quantities of oil.

- ◆ Auto lift feature for the fry-basket
- ◆ Computerised touch controls
- ◆ Removable parts for ease of cleaning



EF-12 Auto



Technical Specifications



Model	Power	Capacity	No. of Baskets	Dimensions (W x D x H in mm)	Auto Lift	Voltage
EF-12 Auto	3 kW	12L	1	270x585x380	Yes	220V/50Hz

Specifications are subject to change without prior notice

Countertop Fryers

These professional fryers from Butler are particularly suited for fast food restaurants. Suitable for frying chips, chicken, fish, onion rings in quick succession using minimal quantities oil. The model EF-8 Premia comes with computerised touch controls

- ◆ Precise bulb thermostat in stainless steel
- ◆ Heat resistant handles in baskets
- ◆ Removable parts for ease of cleaning
- ◆ 4 different models to choose from



EF-4, EF-6, EF-8



EF-8 Premia

Technical Specifications

Model	Power	Capacity	No. of Baskets	Dimensions (W x D x H in mm)	Voltage
EF-4	2 kW	4	1	220x390x370	220V/50Hz
EF-6	2.5 kW	6	1	260x410x285	220V/50Hz
EF-8	3.25 kW	8	1	260x410x340	220V/50Hz
EF-8 Premia	2.5 kW	8	1	280x430x310	220V/50Hz

Specifications are subject to change without prior notice due to continuous product development





Countertop Induction Deep Fryers

This pioneering product from Butler uses patented technology and is ideal for frying in those places where other forms of heating and cooking are avoidable. No flames or hot surfaces provide for a safer, cooler kitchen. They are a boon for food-courts, airports, railways stations and similar applications.

Key Features

- ◆ Touch control
- ◆ Stainless steel body
- ◆ Temperature range: 60°C-190°C
- ◆ Default temperature: 140°C
- ◆ Timer range: 0 - 15 mins, multiples of 30 seconds each
- ◆ Auto power-off: 4 hrs

Twice as fast as conventional fryers



IDF-08 (New)



Technical Specifications



Model	Voltage	Power	Temperature Range	Dimensions (wxdxh)	Timer	Frypot Capacity
IDF-08 (New)	220-240V/50Hz	3500W	60°C - 190°C	288 x 478 x 410mm	0-120 mins	8 Ltrs

Specifications are subject to change without prior notice



CW-819



Chips Warmer

Made in stainless steel, the Butler counter top electric chip dump and warmer is specially designed to keep various types of products viz., fries, donuts, samosas, kachories, chicken wings etc. warm for short intervals after they go through a frying process. This allows the fried stuff to retain its crispiness and taste before final delivery.

Key Features

- ◆ Easy access
- ◆ Simple design
- ◆ Keeps chips and other fried stuff warm and crispy
- ◆ Recommended for short durations

Technical Specifications



Model	Voltage	Power	Dimensions (wxdxh)	Net Weight
CW-819	220V/50Hz	750W	335x575x465 mm	8Kg

Specifications are subject to change without prior notice due to continuous product development







Electric Griddle Plates

These steel fry tops from Butler are ideal for cooking dosas, chillas, paratha, meat, bacon, fish, sausages, fried eggs, omelettes and a wide variety of Indian style tawa preparations.

- ◆ Homogenous cooking
- ◆ Heavy duty heating element
- ◆ Temperature Control
- ◆ Easy to clean



EGP-550



EGP-730FG



Technical Specifications



Model	Power	Temperature Range	External Dimensions W x D x H (mm)	Griddle Dimensions W x D x H (mm)
EGP-550	3kW	50°C-320°C	550x450x230	548x348x10
EGP-730FG	4.4kW	50°C-300°C	730x530x260	728x396x10 2/3rd Plain, 1/3rd Grooved

Voltage: 220-240V/50Hz Specifications are subject to change without prior notice due to continuous product development

Contact Grills - Grooved

The Butler Euro Grill is an electric contact grill that comes in two variants both with grooved top and bottom plates. These models are designed leave grill marks and cook perfect jumbo sized sandwiches, paninis, steaks or hamburgers retaining all juices and vitamins or grill fish, eggplant or similar foodstuff.

- ◆ Cast iron plates for even cooking
- ◆ Self-balanced upper plate
- ◆ Euro Grill Premia/PG-11E Premia model comes with the Timer and Touch Control Screen
- ◆ Euro Grill/PG-11E model comes with simple to use, electromechanical controls



Euro Grill



Euro Grill Premia



Technical Specifications

Model	Power	Temperature Range	Dimensions W x D x H (mm)	Cooking Surface (mm)	Net Weight
Euro Grill	2.8 Kw	50°C-300°C	430x310x200	340 x 230	25 Kg
Euro Grill Premia	2.8 Kw	50°C-300°C	425x400x210	340 x 230	21 Kg

Electricals : 220 V

Specifications are subject to change without prior notice due to continuous product development

Contact Grills - Flat

The Butler Indo Grill Premia/ FPG-11E Premia an electric contact grill is specially designed with flat top & bottom plates and are suitable for cooking or regenerating paranthas, chillas, mini uttapams, mini dosas, wraps, steaks or similar foodstuff that does not require grill marks. The advantage of this model is that it is easy to clean.

- ◆ Timer and Touch Control Screen
- ◆ Cast iron plates for even cooking
- ◆ Self-balanced upper plate



Indo Grill Premia

CE



Technical Specifications

CE

Model	Power	Temperature Range	Dimensions W x D x H (mm)	Cooking Surface (mm)	Net Weight
Indo Grill Premia	2.8 Kw	50°C-300°C	425x400x210	340 x 230	21 Kg

Electricals : 220 V

Specifications are subject to change without prior notice due to continuous product development





RWB-04

Rotary Waffle Bakers

The rotary waffle bakers from Butler come with an electro-mechanical timer and can accept deep-frozen, frozen pre-cooked waffles or freshly made batter for making golden crispy waffles.

- ◆ Quick and even heat spread
- ◆ Temperature control range: 124°C ~ 230°C
- ◆ Time Control Range: 99 Minutes & 50 Seconds ~ 00 Minutes & 00 Seconds
- ◆ The baking plate can revolve 180° baking evenly across both the plates

Technical Specifications



Model	Power	Weight	Temperature Range	Baking Plate Revolve	Dimensions (W x D x H in mm)	Time Control Range
RWB-04	2kW	10kg	124°C ~ 230°C	180°	310x380x285	50Sec ~ 99Mins

Voltage: 220-240V/50Hz

Specifications are subject to change without prior notice due to continuous product development



Crepe Makers

High quality crepe machines for delicious, moist, golden pancakes, buckwheat cakes, Indian tempura, sweet chillas and the like. The cast iron plate is perfectly smooth and facilitates a direct heat transfer. A slight degreasing of the pancake or crepe would ensure a honeycombed, golden crepe with no caramelization or glazing.

- ◆ Even cooking with minimal use of oil
- ◆ Ideal for outdoor or kiosk use



CM-01

Technical Specifications



Model	Power	Temperature Range	Dimensions (W x D x H in mm)
CM-01	3 KW	50°C-300°C	450×485×235

Electricals : 220 V

Specifications are subject to change without prior notice due to continuous product development

Buffet & Self Service





BM-1/1

Electric Bain Mairies

Butler Bain-Mairies come in a GN 1/1 compatible size and can be easily paired together due to their modular and multi-plexable design to create an excellent food warming option to suit the needs of busy catering environments. They come with 2 x GN 1/2 containers with lids.

Technical Specifications



Model	Power	Dimensions W x D x H (mm)	Temperature Range
BM-1/1	1.8kW	340x560x280	30°C -85°C

Voltage: 220-240V/50Hz Specifications are subject to change without prior notice due to continuous product development

Steamed food is healthy





What is a steam oven?

A commercial steam oven is designed to steam cook large quantities of food over multiple shelves. This locks in the nutrients and flavours whilst retaining the food texture and preventing flavour transfer to other foodstuffs in the oven. Commercial steam ovens are usually considered a primary appliance in a professional kitchen. Whilst typical dishes cooked in a steam oven could be fish, vegetables or desserts, some chefs use the appliance to cook all these dishes simultaneously.

Commercial steam ovens are usually powerful enough to handle multiple pans of food - perfect for busy commercial kitchens, cloud kitchens, staff canteens, mass catering sites or events.

5 Key reasons to use a steam oven

- ◆ Food retains colour: Vegetables can quickly lose their colour when overcooked or boiled. Steaming helps to keep carrots, asparagus and other veggies closer to their natural colour in comparison to other cooking methods.
- ◆ Food retains flavour, texture and nutrients: Steam cooking foods helps to seal in flavours, vitamins and moisture, leaving the food much closer to its natural state in comparison to conventional cooking. Over-boiling/roasting/frying can turn foodstuff to be mushy, unappealing, dry or rubbery. Steaming helps reduce the chance of this happening.
- ◆ Cook multiple items together: With steam cooking, it's difficult for flavours to transfer between the contents of the oven. As a result, many different dishes can be cooked together with minimal flavour transfer. What's more, this means that the single appliance can cook many items.
- ◆ Versatility: Steam is suitable for cooking many different types of food ranging from rice, idlis, dhokla, chicken, seafood, vegetables, desserts and fruit, to meats, pasta, dimsums and more.
- ◆ Speed: Steam cooks food much faster than hot air and reduces shrinkage, improving productivity, and increasing profits for the food service establishment. Steam equipment is relatively easy to use, even for the inexperienced food service operator.

Steam Cooking Process

Steamers look and operate much like ovens. An electric or gas boiler generates the steam and injects this steam into the cooking compartment. Steam is a much quicker heat transfer medium than hot air. For example, a full size turkey may take hours to cook in a conventional hot air oven, but will cook in minutes in a steamer.

Steamers are relatively quick ovens to preheat because of the high heat transfer characteristics of steam. Therefore, they require less energy to stay up to temperature during slow times.

In addition, steam energy is transferred at lower temperatures thereby reducing the chance of overcooking the food product. For example, steamers operate at temperatures of 100° to 115°C, while a typical hot-air ovens operate between 175° and 240°C.

However, cooking at this lower temperature does not brown food as effectively as a hot-air oven. This is why chefs will often use the steamer to cook food almost to completion, and then transfer that food to a conventional oven for a short period of time for surface browning. They may also use a combination steam/hot air oven designed to do both.



Getting the best out of your Steam Master

- ◆ Try to keep the unit fully loaded when possible. The steamer operates at peak efficiency and productivity at full load.
- ◆ One key ingredient to steamer operation is controlling water quality to the steamer. Appropriate water treatment will help you avoid premature steamer component failures.

The limitations

Even though steam ovens are superbly useful, they have one notable handicap. They cannot brown food. For the best tastes and textures, most meats should be finished in a pan or a salamander grill. Similarly, pies, breads and pastries can look pale when cooked using only steam. However, that does not negate the positives already listed.

Steamers

The Butler Steam Master is a versatile equipment that can steam a wide variety of items including rice, corn, idlis, dhoklas, momos, potatoes, vegetables, eggs, fish, chicken and more. It is way more cost effective an appliance as compared to combi steamers when the requirement is essentially steaming. Made in high quality stainless steel it is also energy efficient and comes with several safety features viz., door locking system, dry fire protection and an auto water feeding float ball. It is available in electric and gas versions.



Steam Master

Approximate Cook Time

- ◆ Seafood 15 minutes
- ◆ Meat(chicken) 35 minutes
- ◆ Bun 40 minutes
- ◆ Rice 45 minutes
- ◆ Stew 60 minutes



Technical Specifications



Model	Voltage	Power	Dimensions WxDxH (mm)	Input Steam Pressure	No. of Trays	Tray Size (mm)	Tray Material	Max weight per tray	Weight
Steam Master-E	380V/50Hz	9.0KW	700*600*1070	0.02Mpa	6	600*400	SS 304	Max 3.5 kgs	50 KG
Steam Master-G	220V/50Hz	-	700*700*1220	-	6	600*400	SS 304	Max 3.5 kgs	-
Steam Master-12E	380V/50Hz	12.0KW	700*600*1580	0.02Mpa	12	600*400	SS 304	Max 3.5 kgs	-
Steam Master-12G	220V/50Hz	-	700*680*1720	-	12	600*400	SS 304	Max 3.5 kgs	-

Specifications are subject to change without prior notice due to continuous product development

Electric Salamanders

Butler salamanders can be used to defrost, brown, grill toasts, gratins, pizzas, onion soups etc. without preheating.

- ◆ High quality cooking
- ◆ Easy to clean



ES-610

CE

Model	Power	Temperature Range	Dimensions (W x D x H in mm)
ES-610	1.82~2 kW	50°C-300°C	610x340x280

Electricals : 220 V

Specifications are subject to change without prior notice



Chafing Dish Warmers

Though not based on induction technology, this is an innovative product from Butler designed to warm traditional metallic chafing dishes thereby allowing warm food to maintain itself at the right temperature whilst improving your presentation and helping you eliminate the use of burners.

Key Features

- ◆ Keep warm at 90°C
- ◆ Power: 220-240V ~ 50Hz, 500W
- ◆ Dimensions:
Ø138mm x 110mm (h)



InnoWarm

Pass Through Bun Toaster

Butler's Bun Toasters come in a choice of two options - Pass Through Type (model PT-BT) and Batch Type (model BT-05). They are a great choice for toasting buns for burgers and sandwiches. They are designed to deliver higher toasting capacities. A strong motor and higher temperature platen increase performance, that caramelizes the bread and prevents it from getting soggy from the juices and condiments. Adjustable bun crush controls and thermostat allow for precise toasting for various bread products.



PT-BT



BT-05

Technical Specifications



Model	Power	Weight	Dimensions (W x D x H)	Electricals
BT-05	2000 ~ 2400W	-	410x700x300 mm	220V / 50 Hz./1Ph
PT-BT	1600W	26 kgs.	420x250x585 mm	220V / 50 Hz./1Ph

Specifications are subject to change without prior notice due to continuous product development



Breakfast essentials



Pop-up Toasters

The 6 slot pop-up toaster from Butler is built to suit the heavy duty needs of busy kitchens and restaurants. It comes with a bottom crumb tray for bread particles.

- ◆ 6 slot toaster
- ◆ Stainless Steel construction
- ◆ Rounded edge design
- ◆ 5 minute timer



POP-06

Model	Power	Electricals	Dimensions (WxDxH in mm)
POP-06	3.24 KW	220V / 50Hz	460x210x225

Specifications are subject to change without prior notice



CT-300



Conveyor Toasters

Butler conveyor toaster is designed to toast bread and buns fast - over 300 slices per hour. It works on belt speed and not temperature, to determine the colour of toasting.

- ◆ Robust, stainless steel construction
- ◆ Easy to load guide rack
- ◆ Adjustable speed belt
- ◆ Flexibility to choose front or rear discharge
- ◆ Easy to clean and removable trays

Model	Power	Dimensions W x D x H (mm)	Chamber Dimensions W x D x H (mm)	Temperature Range	Heating Elements	Fans
CT-300	2.67kW	595x530x570	460x375x360	50°C -300°C	2	2

Voltage: 220-240V/50Hz

Specifications are subject to change without prior notice

Serving it warm
and pronto

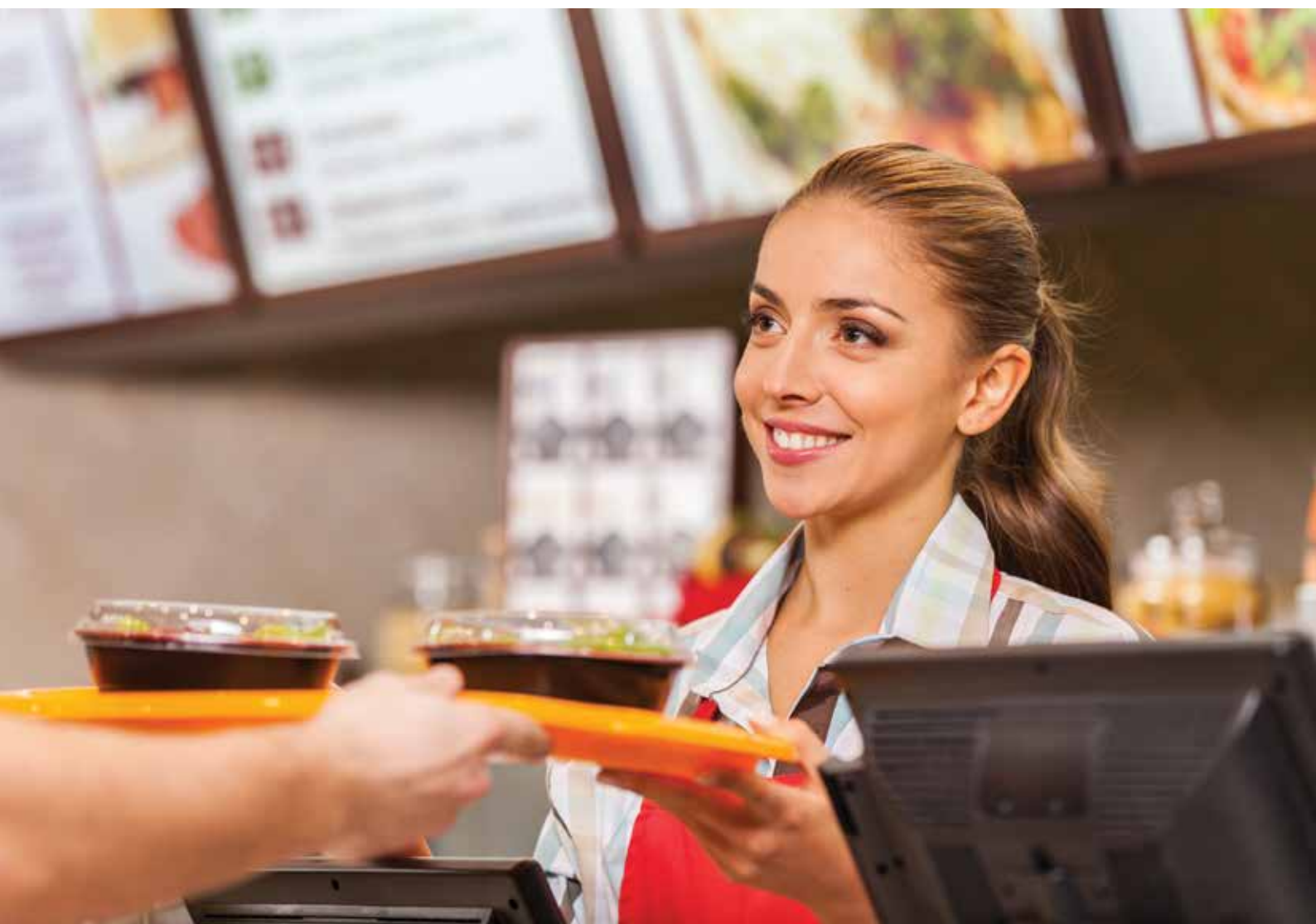

Commercial Microwave Ovens

The Butler commercial microwave ovens are a perfect replacement for inappropriate domestic ovens used in food-service applications. They bake fast and evenly and are suitable for a wide variety ranging from pastries to entries. The durable construction is perfectly adapted for commercial usage such as caf  s, food stores, pizza outlets, casual dining restaurants, clubs, deli applications and more.



MWO-25



MWO-34HD

Cheeseburger



9 oz. cheeseburger can be reheated within 3 minutes

Sandwich



8 oz. sandwich can be reheated within 1 minute

Lasagna



8 oz. lasagna can be cooked within 20 minutes and preheated in 3 minutes

Nachos



10 oz. nachos can be reheated within 2 minutes

Difference between commercial and household microwave ovens

	Commercial Microwave Ovens	Conventional Microwave Ovens
Functions	<ul style="list-style-type: none"> ◆ Even heat delivery to the food, large capacity, pre-set memory, one button for common menus ◆ Three power levels and automatic fault diagnosis 	<ul style="list-style-type: none"> ◆ Slow heating, unsuitable for commercial applications, rely on turntable for even heating ◆ No automatic fault diagnosis
Durability	<ul style="list-style-type: none"> ◆ Stainless steel cavity ◆ Withstands frequent usage (100s of times per day) 	<ul style="list-style-type: none"> ◆ Sprayed or painted doors ◆ Only for home use (3-5 times per day)
Cleaning	<ul style="list-style-type: none"> ◆ Smooth internal and external design, easy to clean 	<ul style="list-style-type: none"> ◆ Turntable structure leads to accumulation of residues, difficult to clean
Capability	<ul style="list-style-type: none"> ◆ Heating not compromised by large capacity 	<ul style="list-style-type: none"> ◆ Can accommodate limited amount of food

Touch Control Panel

MWO-25

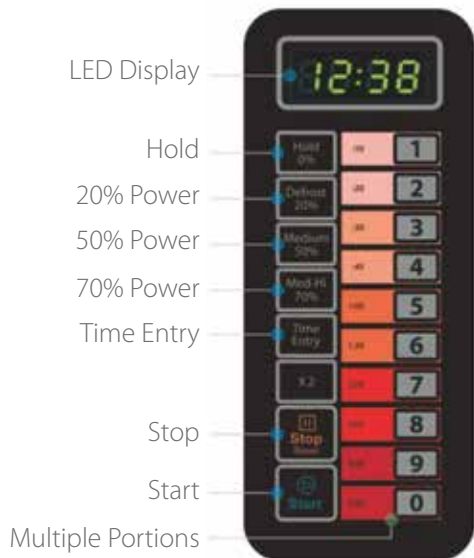

MWO-34HD

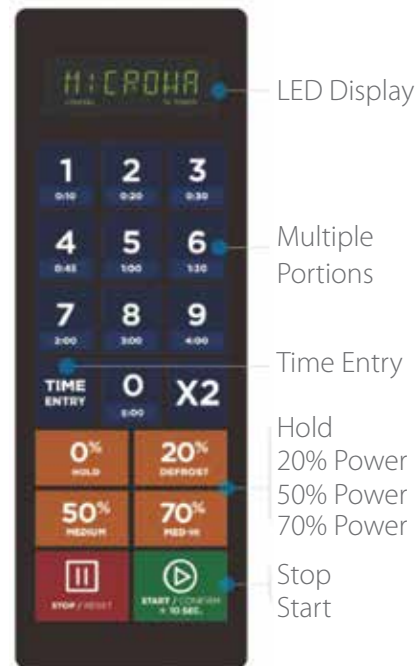

MWO-25

- ◆ 25 litre capacity accommodates 12" platter
- ◆ Up to 20 programmable menu options for consistent results
- ◆ User friendly touch control pad
- ◆ 3 stage cooking and 5 microwave power levels
- ◆ See-through door with lighted interior
- ◆ Grab'n Go handle
- ◆ Stainless steel cabinet and oven cavity
- ◆ Removable splatter shield

MWO-34HD

- ◆ 34 litre capacity accommodate 16" platters
- ◆ Up to 100 programmable menu options for consistent results
- ◆ User friendly touch control pad
- ◆ 3 stage cooking and 5 microwave power levels
- ◆ See-through door with lighted interior
- ◆ Grab'n Go handle
- ◆ Stainless steel cabinet and oven cavity
- ◆ Removable splatter shield
- ◆ Stackable installation

Technical Specifications

Model	External Dimensions W x D x H (mm)	Cavity Dimensions W x D x H (mm)	Cavity Volume (Litres)	Input Power (W)	Output Power (W)	Cooking Time (min:sec)
MWO-25	511x311x432	327x200x346	25	1550	1000	3:10
MWO-34HD	553x488x343	370x385x230	34	1900	1400	2:30

*Throughput reflects one piece of Pizza

Specifications are subject to change without prior notice due to continuous product development

When speed & quality are vital



Ventless High Speed Ovens

The Butler Ventless High Speed oven is a revolutionary appliance designed to combine three technologies- convection, accelerated air impingement and microwave. While microwaves offer fast cooking, they can often result in meals that are soggy and devoid of quality textures like crispy crusts. With Butler High Speed Ovens, this would be a thing of the past. They are designed to churn out great tasting food, quickly and consistently. They're also great space savers, reducing the need for multiple cooking appliances and the built-in catalytic converter breaks down grease-laden vapours, allowing for a ventless operation.



Concorde / Concorde Plus

The little wonder from Butler

Catalytic converter



The built-in catalytic converter breaks down grease-laden vapours, allowing for a ventless operation.

that cooks a surprisingly large variety of food

up to 20 x faster



Coffee Shops



Casual Dining



Hotels & Resorts



Airports



Quick Service Restaurants



Cloud Kitchens



Theaters

Typical Cook Times: Butler High Speed Ovens

Item	Concorde	Concorde Plus
9" Pizza-Fresh Dough (600g)	110 seconds	60 seconds
9" Pizza-Parbaked, Refrigerated	70 seconds	40 seconds
Samosa	60 seconds	40 seconds
12" Sub Sandwich	40 seconds	20 seconds
12" Sub Sandwich (Qty 2)	50 seconds	30 seconds
Paneer Pakora	60 seconds	40 seconds
6" Hamburger (Qty 2)	40 seconds	20 seconds
6" Hamburger (Qty 4)	50 seconds	30 seconds
Kachori	60 seconds	40 seconds
Muffin (Qty 4)	50 seconds	30 seconds
Cinnamon Rolls (frozen, par-baked)-Qty 6	70 seconds	40 seconds
Puff Patty	60 seconds	40 seconds
French Fries (2x170g)	160 seconds	90 seconds
Apple Strudel (300g)	120 seconds	70 seconds
Nachos (120g)	30 seconds	20 seconds
Sausages (15x56g)	150 seconds	90 seconds
Steak (600g)	330 seconds	210 seconds
Chicken Wings (8 count, Frozen)	170 seconds	100 seconds
Chicken Tenders (Frozen, 900g)	240 seconds	140 seconds
Roast Meat (block, 650g)	240 seconds	140 seconds

Butler Ventless High Speed Oven is a versatile, all-in-one cooking oven with an ability to cook, toast, grill, regenerate and bake a wide range of fresh or frozen foods, such as sandwiches, paninis, pizzas, burritos, toasties, quesadillas, samosas, fish, vegetables, kebabs, steaks and a lot more and offer the following benefits.

- ◆ Simple operation with Touchscreen control
- ◆ Up to 20 x faster preparation times
- ◆ Pre-programming on PC
- ◆ Download recipes via the USB port
- ◆ Rapid cooking with high quality repeatable results
- ◆ Ventless operation



Samosas



Pizzas



Quesadilla



Caprese Sandwich



Burritos



Cinnamon Rolls



Lasagna



Muffins



Pasta



Burgers & Fries



Panini Grills



Steaks



Wraps

Technical Specifications - Ventless High Speed Ovens

Accessories



Oven shovel



Basket



Non stick baking pad



Baking stone



Pan



Rack

Parameters	Concorde	Concorde Plus
Dimensions (Wx D x H)	383 X 693 X 610 mm	
Dimensions Chamber	320 x 320 x 195 mm	
Weight	65Kg	77Kg
Cooking Speed	10 times faster	20 times faster
100% Microwave	1-Mag/ 1100 W	2-Mag/ 2200 W
Impingement	1-heater/1600 W	2-heater/3800 W
Combi mode	1100w+1600 W	2200 W + 3800 W
Max Power	3500 W	6500 W
Max Current	16A	32A
Power Source	1-Ph / 220-240V / 50Hz	3-Ph / 380-440V / 50Hz
Frequency	2450MHz	
Display	Touch screen	
Temp Mode	3- mode	
Programmable Settings	432 recipes	
Program Menu	Multi-level menu capability	
Temp Setting	0-280°C in 2°C steps.	
Time Setting	00:00-59:50 in 10 second steps	
Micro Setting	0-100% in 10% steps	
Fan Setting	10-100% in 1% steps	
Edit	Can edit recipe data and images on both PC and ovens	
Load	USB port to load recipes and images	
Rack	Removable rack	
Door Opening	Pull down	
Exterior Finish	Stainless steel	
Interior Finish	304 Stainless steel	

Specifications are subject to change without prior notice

IMPORTANT: Butler High Speed Ovens require installing a type D circuit breaker for all installations.



Baking is love made edible

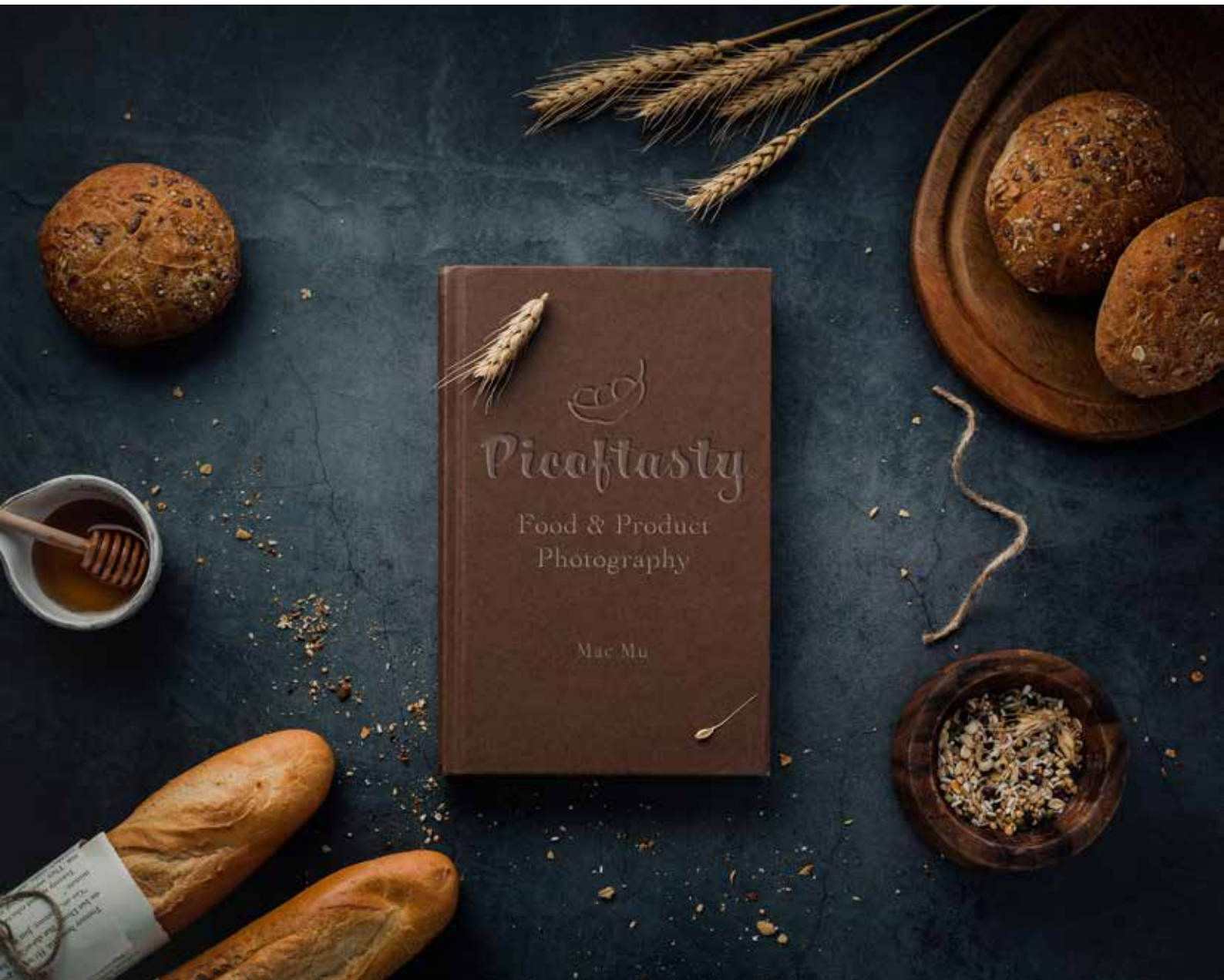

Luxury Deck Ovens

These high-end Butler electric & gas based Deck Ovens come with microcomputer controller & steam generator. The outer cabinet is finished in brushed stainless. They are specially designed for baking bread, cakes, croissants, pastries and more. Using infrared radiant heating tube, they bake the food rapidly and uniformly. The required temperature can be set up to 400°C and controlled automatically. Ideal for hotels, restaurants, bakehouses and bread shops, each deck comes with two variants - one that can accommodate 2 EN trays and the other that can place 3 EN trays inside the baking chamber.



Electric: EFO-1D-2C, EFO-1D-3C
Gas: GFO-1D-2C, GFO-1D-3C



Electric: EFO-2D-4C, EFO-2D-6C
Gas: GFO-2D-4C, GFO-2D-6C



Electric: EFO-3D-6C, EFO-3D-9C
Gas: GFO-3D-6C, GFO-3D-9C



Technical Specifications - Luxury Deck Ovens



Product	Model	Power/Gas Power	Weight	Dimensions (W x D x H) mm	Electricals	Trays
Electric Single Deck Oven	EFO-1D-2C*	6.8 kW	130 kgs.	1355 x 960 x 700	1-220V / 50Hz	2 x EN Trays
Electric Two Deck Oven	EFO-2D-4C*	13.6 kW	220 kgs.	1355 x 960 x 1255	3-380V / 50 Hz	4 x EN Trays
Electric Three Deck Oven	EFO-3D-6C*	20.4 kW	310 kgs.	1355 x 960 x 1645	3-380V / 50 Hz	6 x EN Trays
Gas Single Deck Oven	GFO-1D-2C*	120W/45MJ/H	130 kgs.	1355 x 960 x 720	1-220V / 50Hz	2 x EN Trays
Gas Two Deck Oven	GFO-2D-4C*	240W/90MJ/H	220 kgs.	1355 x 960 x 1375	1-220V / 50Hz	4 x EN Trays
Gas Three Deck Oven	GFO-3D-6C*	360W/135MJ/H	310 kgs.	1355 x 960 x 1835	1-220V / 50Hz	6 x EN Trays
Electric Three Tray Single Deck Oven	EFO-1D-3C*	8KW	-	1775 x 960 x 720	3-380v/50hz	3 x EN Trays
Electric Six Tray Two Deck Oven	EFO-2D-6C*	16KW	-	1775 x 960 x 1350	1-380v/50hz	6 x EN Trays
Electric Nine Tray Three Deck Oven	EFO-3D-9C*	24KW	-	1775 x 960 x 1835	1-380v/50hz	9 x EN Trays
Gas Three Tray Single Deck Oven	GFO-1D-3C*	120W/ 8.3KW/H	-	1775 x 960 x 720	1-220v/50hz	3 x EN Trays
Gas Six Tray Two Deck Oven	GFO-2D-6C*	240W/ 16.6KW/H	-	1775 x 960 x 1350	1-220v/50hz	6 x EN Trays
Gas Nine Tray Three Deck Oven	GFO-3D-9C*	360W/ 25KW/H	-	1775 x 960 x 1835	1-220v/50hz	9 x EN Trays

Temperature Range - 0 ~ 400°C (The default setting of temperature is 300°C and can be increased upto 400°C by programming the micro computer controller.)

Gas based ovens can work on LPG.

* These models are microcomputer controlled & come with a steam generation feature.

Specifications are subject to change without prior notice due to continuous product development





OVP-1212



OVP-1224

Electric Ovens & Proofers

This unified range of Butler Electric Ovens cum Proofers come in two variants - a 1 deck/ 2 tray or a 2 deck/4 tray electric oven built atop a 12 tray proofer. The outer cabinet is finished in brushed stainless. The oven is designed for baking bread, cakes, pastries and more. The proofer section at the bottom allows you to set the perfect temperature and humidity levels and can accommodate 12 pans (not supplied with the machines).



Technical Specifications - Electric Ovens & Proofers



Model	Power	Weight	Dimensions (W x D x H) mm	Internal Dimensions of Each Oven (W x D x H)	Electricals	Temperature
OVP-1212	9.2KW	125 kgs.	1300x830x1420	870 x 670 x 200mm	380V / 50 Hz	0-400°C (Oven) / 0-110°C (Proofer)
OVP-1224	15.8KW	210 kgs.	1300x830x1815	870 x 670 x 200mm	380V / 50 Hz	0-400°C (Oven) / 0-110°C (Proofer)

Specifications are subject to change without prior notice due to continuous product development

Trays not supplied with the machines.



Electric Convection Ovens with Steam

These convection ovens with steam regulation are ideal for bakeries, snack bars and cake shops that need to heat up or cook croissants, pastry, bread or simple dishes. Electric ovens with a side opening strong hinged door, advanced computer controls, 4 x 1 EN trays with an average pitch of 70-90 mm, they come with a stainless steel AISI 304 cooking chamber.



ECO-920S

Technical Specifications



Model	Power	Voltage	Trays	External Dimensions W x D x H (mm)	Internal Dimensions W x D x H (mm)	Tray Size W x D (mm)	Control Panel
ECO-920S	6.0kw	220V/50Hz	4	920 x 815 x 600	645 x 455 x 420	580 x 400	Touch Pad
ECO-920S	6.0kw	380V/50Hz	4	920 x 815 x 600	645 x 455 x 420	580 x 400	Touch Pad

Specifications are subject to change without prior notice due to continuous product development
Trays not supplied with the machines.



ECO-28-2T Premia



ECO-28 (New)

Electric Convection Ovens

Butler convection ovens allow you to bake like a professional. They are designed for cooking or reheating croissants, chocolate buns, pastries or cookies, lasagna, baked potatoes and a wide variety of fresh frozen or pre-raised savories.

- ◆ Fan assisted heating ensures a quick rise in temperature up to 350°C
- ◆ Easy to clean chamber
- ◆ Double glass door; openable at 90° enables easy pullout of trays
- ◆ Advanced motor and heavy duty fan blades
- ◆ ECO-28-2T Premia comes with 2 trays and ECO-28-4T (New) comes with 4 trays



Technical Specifications



Model	Power	Dimensions W x D x H (mm)	Chamber Dimensions W x D x H (mm)	Pans W x D x H (mm)	Temperature Range	Trays
ECO-28-2T Premia	2.5kW	670 x 650 x 395	465 x 370 x 270	0°C - 350°C	2	
ECO-28 (New)	4.5kW	670 x 650 x 470	460 x 370 x 350	440 x 318 / 4pans	0°C - 350°C	4

Voltage: 220-240V/50Hz Specifications are subject to change without prior notice due to continuous product development
Trays not supplied with the machines.



Table Top Tilt-head Mixers

The Butler B-5 & B-7 stand mixer has a 300-watt motor, 5 litre stainless steel bowl with ergonomic handle, pouring shield and a tilt-back mixer head design that provides easy access to bowl and beaters.

- ◆ 10-Speed Solid-State Control



B-5, B-7



Wire Whip

- Cooks dough
- Cake batter
- Dips & sauces



Flat Beater

- Whipped cream
- Egg Whites
- Cake batter



'C' Dough Hook

- Yeast Dough
- Mixes
- Kneads

Technical Specifications



Model	Bowl Volume	Power	Max Kneading Capacity	Mixing Speed (rpm)	Dimensions (WxDxH) mm	Electricals
B-5	5 ltrs.	0.3 KW	0.5 - 0.8 kgs.	45 ~ 260	230x350x400	220V/50 Hz./ 1 Ph
B-7	7 ltrs.	0.32 KW	0.5 - 1.5 kgs.	45 ~ 260	400x250x410	220V/50 Hz./ 1 Ph

Specifications are subject to change without prior notice due to continuous product development

Planetary Mixers

Like in the cosmic planetary movement, the beaters in these mixers move like planets in the bowl so that the food is mixed thoroughly. Butler high performance planetary mixers are suitable for mixing of flour, foodstuff and also for egg beating. All parts are made of quality stainless steel to ensure that they meet the required hygiene standards for food. They are simple to operate and easy to clean.



PM-10, PM-20



PM-30, PM-40



PM-60

Technical Specifications



Model	Bowl Volume	Power	Max Kneading Capacity	Mixing Speed (rpm)	Weight	Dimensions (W x D x H) in mm	Electricals
PM-10	10 ltrs.	0.6kw	2.5 kgs.	148/244/480	45KG	470x420x620	220V/50 Hz./ 1 Ph
PM-20	20 ltrs.	1.1kw	5 kgs.	462/317/197	65KG	540x470x810	220V/50 Hz./ 1 Ph
PM-30	30 ltrs.	1.5KW	7 kgs.	462/317/197	71KG	620x520x890	220V/50 Hz./1 Ph
PM-40	40 ltrs.	2.1KW	9 kgs.	520/187/120	170KG	600x750x1100	220V/50 Hz./1 Ph
PM-60	60 ltrs.	2.3KW	25 kgs.	458/221/114	400KG	600x750x1100	380V/50 Hz./3 Ph

Specifications are subject to change without prior notice due to continuous product development



Spiral Mixers

Butler high performance and durable spiral mixers are specially designed for dough mixing application in bakeries, hotels and restaurants. In the spiral mixing methodology, both the mixer and bowl revolve simultaneously, thus giving an enhanced mixing effect. They come with a safety cover and all parts that come in contact with food are made of stainless steel.



SM-20T



SM-34T



SM-45T

Technical Specifications



Model	Bowl Volume	Power	Max Kneading Capacity	Mixing Speed (rpm)	Bowl Speed (rpm)	Dimensions (W x D x H) in mm	Electricals	Weight
SM-20T	20 ltrs.	1.5KW	8 kgs.	150/200	15/20	390 x 730 x 900	220V/50 Hz/ 1 Ph	90KG
SM-34T	34 ltrs.	1.5KW	12 kgs.	150/200	15/20	435 x 750 x 900	220V/50 Hz/ 1 Ph	100KG
SM-45T	45 ltrs.	3.0KW	16 kgs.	150/200	15/20	480 x 800 x 970	220V/50 Hz/1 Ph	115KG
SM-200	200 ltrs.	5/7.5KW	75 kgs.	210/107	16	950 x 1332 x 1510	380V/50 Hz/3 Ph	675KG

Specifications are subject to change without prior notice due to continuous product development



DS-520FS



DS-520

Dough Sheeters

Butler Dough Sheeters are designed to take a ball of dough, roll it and stretch it out to a thickness ranging from 0.5 mm to 30 mm. They come with special motors and work on a two-way pressing mechanism that avoids tearing of the dough whilst optimising the output. Available in two versions - table top or with a stand, they are equipped with a safety shield and designed to operate smoothly, safely and reliably. All parts that come in contact with food are made of stainless steel or are specially plated to meet the required hygiene standards for food.

Technical Specifications



Model	Power	Weight	Dimensions with Trays Pulled-out (W x D x H)	Dimensions without trays Pulled-out (W x D x H)	Remarks
DS 520FS	0.75 kW	255 kgs.	2780 x 875 x 1230 mm	2080 x 875 x 1230 mm	133 rpm / Roller length 520 mm
DS-520	0.75 kW	216 kgs.	2780 x 875 x 650 mm	2080 x 875 x 650 mm	133 rpm / Roller length 520 mm

Voltage: 220-240V/50Hz

Specifications are subject to change without prior notice due to continuous product development



PDR-40

Pizza Dough Rollers

Butler Pizza Dough Rollers are designed to compress the dough between the rotating rollers. They are ideal for producing smooth and consistent dough sheets in the required thickness. Two pairs of parallel and adjustable rollers to allow for variation in thickness of pizza dough and for either square or rectangular sheet. You can obtain a round sheet by just turning the dough around 90° once it comes out of the upper rollers and before it enters the lower rollers.

Technical Specifications



Model	Power	Weight	Dimensions (W x D x H)	Electricals	Remarks
PDR-40	0.37 kW	39 kgs.	540 x 550 x 650 mm	220V / 50 Hz.	Pizza Diameter 400 mm / Dough Weight 50g - 500g

Specifications are subject to change without prior notice due to continuous product development



Dough Dividers

Butler Automatic Dough Dividers are specially designed to take a large batch of dough and portion it out into equally sized and weighted balls of dough for consistent results when making pies, breads, or even pizza crusts. Made in high quality stainless steel, these stable, low noise machines work on a hydraulic transmission, capable of dividing the dough into 36 pieces (30- 100gm) at one go. They are mounted on heavy duty castors for ease of mobility.



DD-36

Technical Specifications



Product	Model	Power	Weight	Dimensions (W x D x H)	Electricals	Remarks
Dough Divider	DD-36	1.5 kW	200 kgs.	520 x 420 x 1400 mm	220V / 50 Hz.	36 pcs. (30 - 100 gms.)

Specifications are subject to change without prior notice due to continuous product development

A close-up photograph of a chef's hands grating a wedge of yellow cheese onto a salad. The chef is wearing a white chef's coat. The grater is a metal zester, and the cheese is falling in thin shreds. The salad in the white bowl below contains sliced cucumbers, black olives, and green leafy vegetables. The background is dark and out of focus.

Food preparation
made easy

Commercial Blenders

Butler TruBlend blenders are ideal for restaurants, cafes and other commercial applications. They are perfect for crushing ice in seconds, making cocktails, frothy milkshakes, smoothies, frappes, cold coffee and more. TruBlend 2.2AQT model features an advanced acoustic enclosure that reduces blending noise by up to 80%.



Trublend 2.2 AQT



Trublend 2.2 T

Technical Specifications

Model	Power	Motor Power	Jar Capacity	Timer
TruBlend 2.2 T	1680W	2.2 HP	2.5 Litre	Yes
TruBlend 2.2 AQT	1680W	2.2 HP	2.5 Litre	Yes

Voltage: 220-240V/50Hz

Specifications are subject to change without prior notice due to continuous product development



Meat Slicers

These semi-automatic meat slicers from Butler come with high quality bearing design that allows for a smooth operation. The handle is safe and convenient to use when in operation. They are easy to clean, are durable and have a firm-grip base.



SL 250 ES-10

Model	Power	Dimensions W x D x H (mm)	Blade diameter	Cutting thickness	Net Weight
SL 250 ES-10	320W	390 x 470 x 380	250mm/10"	0~10 mm	15.5 kgs

Voltage: 220-240V/50Hz

Specifications are subject to change without prior notice



TC-8



Meat Mincers

These durable meat mincers from Butler come with an all stainless steel construction. They are easy to operate & clean; conform to international sanitation standards. All models are loaded with an easy to replace, circular orifice knife and cross-blades.

Model	Power	Dimensions W x D x H (mm)	Capacity	Net Weight
TC-8	350W	370 x 230 x 470	80 kgs /h	20 kgs

Voltage: 220-240V/50Hz

Specifications are subject to change without prior notice

Hamburger Patty Press

The Butler Manual Hamburger Patty Press has a simple, functional design. It is designed to be used in restaurant kitchens and for food processing. The whole body is made of aluminium and the patty bowl is made in stainless steel confirming to international sanitation standards. The platform is firm and durable making the patty press easy to operate and clean.



SL-H100

Model	Patty Diameter	Dimensions W x D x H (mm)	Net Weight
SL-H100	110mm	230 x 165 x 280	4.6 kgs

Voltage: 220-240V/50Hz
Specifications are subject to change without prior notice due to continuous product development

Table Top Vacuum Packing Machine

Vacuum packing is a method of packaging that removes air from the package prior to sealing. ... On a more short-term basis, vacuum packing can also be used to store fresh foods, such as vegetables, meats, and liquids, because it inhibits bacterial growth. Vacuum packing greatly reduces the bulk of non-food items.

The Butler vacuum packing machine facilitates the extension of the shelf life of raw or cooked foods, without weight loss, without drying out or mixing of flavours and odours. It perfectly packages products in vacuum bags and practical reusable containers, inside or outside the vacuum chamber. The transparent tempered glass lid provides better visibility of the product during packaging.



DZ 400T



Model	Electricals	Power	Sealing length	Sealing Width	Thickness	Chamber Dimensions	Dimensions DxWXH (mm)	Weight
DZ 400T	220V/50Hz	0.9KW	400mm	10mm	0.1-0.5mm	440x420x75mm	550x640x600mm	75kg

Specifications are subject to change without prior notice due to continuous product development

Flat Packed Stainless Steel Furniture

The knocked down stainless steel furniture range from Butler perfectly complements its cooking and food preparation equipment. Built in solid 0.8mm stainless steel, it is easy to install and aims to comprehensively address the equipment needs of commercial kitchens.

Work Tables with Splash Back



- ◆ Flat packed
- ◆ Easy to install
- ◆ Four side table support for stability

Model	Description	Dimensions (WDXH) mm
WT.1200SB	Work Table with Splash Back - 1200 mm	1200*700*850+100

Specifications are subject to change without prior notice

Work Tables

- ◆ Flat packed
- ◆ Easy to install
- ◆ Four side table support for stability



Model	Description	Dimensions (WDXH) mm
WT.1200	Work Table - 1200 mm	1200*700*850

Specifications are subject to change without prior notice

Stands with 4 shelves



- ◆ Flat packed
- ◆ Easy to install
- ◆ Holes for air ventilation
- ◆ Each shelf designed to accommodate a load 80 kg

Model	Description	Dimensions (WDXH) mm
4S.1200	Stand with 4 shelves - 1200mm	1200*500*1800
4S.1400	Stand with 4 shelves - 1400mm	1400*500*1800
4S.1500	Stand with 4 shelves - 1500mm	1500*500*1800
4S.1800	Stand with 4 shelves - 1800mm	1800*500*1800

Specifications are subject to change without prior notice

Single Layer Wall Shelves

- ◆ Flat packed
- ◆ Easy to install
- ◆ Adjustable shelf height

Model	Description	Dimensions (WDXH) mm
1WS.1000	Single Layer Wall Shelf -1000mm	1000*300*600
1WS.1200	Single Layer Wall Shelf -1200mm	1200*300*600

Specifications are subject to change without prior notice



Exotic Paan Displays





CTSS-5

Refrigerated Paan Displays

Certain cuisines, particularly Indian meals are often concluded with Paan - a mouth freshener wrapped in beetle leaf, being offered as a grand finale. These Countertop Showcases from TruFrost ensure a vibrant display of paans. They are designed in an elegant showcase of glass and steel with a powerful cooling performance coupled with stable humidity & temperature control to keep the 'paans' fresh and prevents them from drying out.

Technical Specifications



Product	Model	Cooling System	Product Dimensions W*D*H (mm)	Volume (Litres)	Product Weight (Kgs.)	Temperature Range (°C)	Refrigerant	Input Power (Watts)
Refrigerated Paan Display	CTSS-5	Static	1200*335*430	52	60	2 ~ +10	R 134a	135

Electricals: 220V/50Hz/1 Phase

Specifications are subject to change without prior notice due to continuous product development

Adopt hygiene standards
that make you stand out



UV Multipurpose Sterilisers

This versatile product from Butler that can sterilise knives, cutlery, small packages, currency notes and masks with UV light. You can also use this for hand towel sterilisation by running the added hot air circulation feature. Ideal for restaurants, salons, business lounges, meeting rooms, reception areas and other health care applications.



UVS-20



Sterilisation & Warming of Hand Towels



Sterilisation of Knives



Sterilisation of Currency Notes



Disinfection of Small Packages

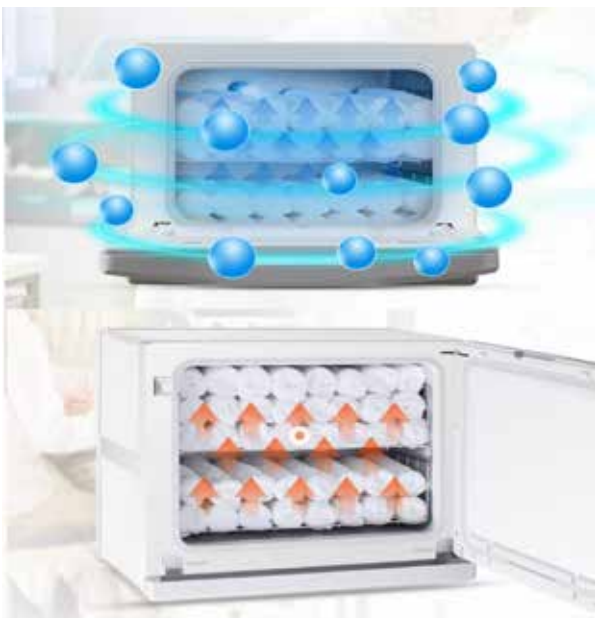

Key Features:

- ◆ Use of UV & high temperature ensures comprehensive cleaning, warming and disinfection
- ◆ Independent control for UV and warming function allows it to disinfect a vast variety of items
- ◆ Holds up to 70 facial/hand towels; also suitable for knives, cutlery, small packages, currency notes and masks
- ◆ UV sanitising function kills up to 99.9% of bacteria
- ◆ Equipped with water tray and interior towel rack
- ◆ Warms towels up to 75 degree C
- ◆ Sterilisation time: 25 minutes
- ◆ The UV light automatically switches off when the door is opened

Technical Specifications



Model	Dimensions (mm)			Electricals	Frequency (Hz)	Power (W)		Temperatures (°C)	Capacity (L)	Weight (Kg)
	W	D	H			Heating	Sterilization			
UVS-20	450	285	330	220V	50/60	180	6	75°C ± 10°C	20	7.5

Specifications are subject to change without prior notice due to continuous product development



When it all comes together



This catalogue is dedicated to the master class of chefs, who through their labour of love, stimulate our senses and bring such joy and happiness into our lives.







Trufrost & Butler

Trufrost Cooling Pvt. Ltd., 1214 & 1215, 12th Floor, Tower B, Emaar Digital Greens,
Golf Course Extn. Road, Sector 61, Gurugram - 122011, India

Tel: +91-124-4246560 Email: info@trufrost.com www.trufrost.com

UAE: +971-54-557-9395, +971-55-676-1323, Email: middleeast@trufrost.com



Andhra/Telangana : 7042027666, 9289143692
Chennai : 7303890587, 9289143691
Chhattisgarh : 7303890590
Coldroom (North): 8448445701, 7303196612
Coldroom (South): 9319399771, 7303890585
Delhi/NCR : 8448759200, 7303890582
Goa : 7303196614

Gujarat : 9319579748
Assam/North-East : 9319391542, 9667795491
J & K / Himachal : 8448319200, 9319399772
Karnataka : 7303890588, 9289143696
Kerala : 7303890587
Maharashtra : 7303890586
Mumbai : 7303196614, 9319579748

Orissa : 7303890590, 9667795491
Punjab / Haryana : 8448319200, 9319399772
Rajasthan : 8448759200
UP : 7303196607
MP : 7303892582
Uttarakhand : 8448319200, 9319399772
West-Bengal/Bihar : 7303890590, 9667795491

Reach-in Cabinets • Undercounter Refrigeration • Blast Freezers • Ice Cubers • Flake Ice Machines • Wine Coolers • Wine Walls • Back Bars • Bottle Coolers • Draught Beer Systems
Soft Serve Freezers • Granita Dispensers • Juice Dispensers • Hot Chocolate Dispensers • Confectionery Display Cases • Chest Freezers & Coolers • Minibars • Multideck Chillers
Deli Counters • Visi Coolers • Visi Freezers • Walk-in Coldrooms • Cold Storages • Pre-Coolers • Ultra Low Freezers • Pharmacy Freezers & Coolers • Blood Bank Refrigeration • Mobile Coolers
Air Sanitisers • Crockery & Cutlery Sterilisers • UV Warm Wipe Sterilisers • Ozone Fruits & Vegetables Disinfectors • Foot Press Water Dispensers



www.trufrost.com