





Two brands - Trufrost and Butler team up to provide a comprehensive bouquet of products designed to provide a cutting edge to bakeries, hotels, restaurants, bars & pubs, coffee shops, ice cream & beverage, food retail & display, food preservation and the bio-medical & healthcare segments. Products that will cook, cool, display and preserve, and let you breathe easy by their tireless performance, extraordinary features and dependable service.



Applications

Trufrost products find great use in applications such as:



Food Retail



Commercial Kitchens



Ice Cream & Juice Bars



Bakeries



Cafés & Cake Shops



Pizza Making



Bars & Pubs



Food Preservation – Coldrooms



Butcheries & Seafood



Research & Medical

Foreword

We are happy to present the Trufrost Butler book - a compilation that is dedicated to our customers who would wish to have a reference document that lays down the exhaustive bouquet of our commercial cooling and foodservice products & solutions for bakeries, hotels, restaurants, bars & pubs, coffee shops, ice cream & beverage, food retail & display, food preservation and the bio-medical & healthcare segments. The more serious professionals, hospitality consultants, architects and designers may like to have this book on their library shelves to be used as a ready-reckoner for more frequent use.

Cheers!

Neeraj Seth
Managing Director

Contents

Professional Refrigeration Products	8
Ice Machines	18
Bar Refrigeration Products	24
Cold Dispensers	34
Confectionery Showcases	40
Visi Cooler & Freezers	62
Chest Freezers & Coolers	90
Freezer on Wheels	100
Cold Rooms	102
Coffee Machines	120
Commercial Blenders	126
Commercial High Speed Ovens	132
Combi Steamers	138
Bakery Equipment	144
Commercial Induction Systems	162
Catering Products	172
Food Prep Equipment	186
Hygiene Products	192
Biomedical Refrigeration Products	200
Manufacturing & Quality	218
Trufrost Experience Centre	220
Our Clients	224





First choice of any chef



With Trufrost, professional chefs can now enjoy the benefits of reliable equipment built with reputed refrigeration system & controllers from Europe, high quality stainless steel, energy saving design, rounded internal edges for complete hygiene, removable magnetic gaskets for ease of cleaning, self-closing doors with heaters to prevent condensation. Our unique Uniblock refrigeration system is a pioneering feature that allows for easy replacement of the refrigeration system in the rare event of a breakdown.

Reach in Cabinets

Trufrost Reach-Ins are available as Chillers or Freezers, or as Dual Temperature Machines, and come with 1, 2 or 4 door options. Available in a choice of two refrigeration systems - Ventilated or Static with fan, these are offered in 550, 600, 625, 1100 and 1350 litre capacities. There are different models to address the wide-ranging needs right from the professional kitchen of a 5 star hotel to a dhaba.

Gastronorm Series & Function Series

Both these premium category reach in cabinets come with a first of its kind uniblock refrigeration system that allows easy replacement and service in the unlikely event of a breakdown. Extremely rugged and based on a forced air ventilation system, they are designed for heavy duty usage in commercial kitchens of Star hotels and busy restaurants who seek a world class quality. The GN series is gastronorm compliant.



Facilitates easy cleaning and hygiene inside the cabinet.



Available Models

G 600 TNM, STF 600 TNM, GN680TNM, G 600 BTM, GN680BTM, STF 550 DTM



Available Models

G 1200 TNM, STF 1200 TNM, G 1210 TNM, GN1340TNM, G 1200 BTM, GN1340BTM, STF 1100 DTM, G 1210 BTM

Economy Series

The Economy series Reach-ins are meant for those who seek a 'no-frills' cabinet that is robust, durable and has great cooling efficiency. Based on a ventilated cooling system, they have a capacity of 600 litres and come with strong, stainless steel door making them an ideal choice for commercial use.



Available Models
G 600 TN

Static Series with Fan Assisted Cooling

These static cabinets come with a specially designed fan assisted cooling system making them capable of working in the trying conditions of a commercial kitchen where a normal static machine just wouldn't do and offer a great value for your money.



Available Models
STF 600 BTM



Available Models
STF 1200 BTM

Reach in Cabinets with Glass Doors

These Trufrost Reach-Ins are available in 1 or 2 glass door options. Available in a choice of two refrigeration systems - Ventilated or Static with fan, these are offered in capacities ranging from 600 - 1410 litres. They are designed to address the wide-ranging needs right from the professional kitchen of a 5 star hotel to a café or a restaurant.



Available Models
GN 740 TNG, GN 740 BTG
STF 600 TNG



Available Models
GN 1480 TNG, GN 1480 BTG
STF 1200 TNG

Ventilated Undercounters

Trufrost refrigerated work tables, mounted on heavy duty lockable castors, combine storage and preparation thereby enhancing the effectiveness of kitchen professionals. Available in a choice of two refrigeration systems - Ventilated or Static with fan, these Chillers or Freezers are available in 2 and 3 door options.



Available Models
G2100TN, GN 2100 TN, STF 2101 TN,
G2100TNG, G2100BT, GN 2100 BT



Available Models
G3100TN, GN 3100 TN, STF 3101 TN,
G3100TNG, G3100BT, GN 3100 BT



Available Models
S 901



Preparation Counters

Trufrost Preparation Counters come in 2 & 3 door variants and bring in an exceptional efficiency to the preparation of pizzas, salads, starters, sandwiches, desserts and more. PS 200V & 300V are compact counters that can house 5 & 8 GN 1/6 pans respectively on their decks while SH 2000 & 3000 models are large enough to house 8 & 10 GN 1/3 pans respectively on their decks.



Available Models
PS-200 (New), PS-300



Available Models
SH-2000/800, SH-3000/800

Chef Counters

Refrigerated Chef Bases from Trufrost are perfect for storing prepped ingredients and are designed to enhance the efficiency of chefs by allowing for placement of countertop cooking equipment right on top of these refrigerated drawers. They also maximise space utilisation by eliminating the traditional equipment stands.



Available Models
CT-36



Available Models
S 900 (2 doors), S 903 (3 doors)



Ventilated Saladettes

Trufrost Saladettes come with a refrigerated display top and a night cover that can take in frozen yogurt toppings, salads and more. S 900 comes with pan supports for 1 x GN 1/1 pan, 3 x GN 1/3 pans and 3 x GN 1/6 pans. S 903 comes with pan supports for 1 x GN 1/1 pan, 4 x GN 1/2 pans and 3 x GN 1/3 pans (not included). The refrigerated section in its underbelly is good for additional storage.

Countertop Cold Display

Trufrost Countertop Cold Display is a versatile appliance. Apart from salads, starters and toppings, it is also ideal for storing a variety of Indian Desserts like kheer, rabadi, rasogullas, ras-malai and phirni on one hand to pani-poori, jal jeera on the other. They accept 5 GN 1/4 pans (not included) and come with a glass sneeze-guard.



Available Models
VRX-1200/330

Countertop Sushi Display

Apart from being a point of attraction on the sushi counter, a Trufrost Sushi Showcase ensures the freshness of foodstuff. Designed with an elegant curved glass, its powerful cooling performance coupled with stable humidity & temperature control keeps sushi fresh and keeps it from drying out. It comes loaded with 5 GN 1/4 pans.



Available Models
CTSS-5

Technical Specifications



Product	Model	Dimensions (wxdxh) mm	Internal Dimensions	Volume (L)	Cooling System	Refrigerant	Input Power (W)	Temperature Range (°C)	GN Compatibility	Door/Drawers	No. of Shelves	Weight (Kg)	
Reach In Refrigerators	G 550 TNM	680x760x1965	560x590x1380	550	Ventilated	R134a	350	-2 ~ +10	-	2	3	98	
	STF 550 TNM	680x760x1965	560x590x1395	550	Static with fan	R134a	175	-5 ~ +10	-	2	3	70	
	G 600 TN	680x710x2010	564x582x1394	600	Ventilated	R290	195	-2 ~ +8	-	1	3	115	
	G 600 TNM (New)	680x710x2010	560x580x1390	600	Ventilated	R600a	225	-2 ~ +8	-	2	4	110	
	STF 600 TNM	680x710x2010	564x582x1394	600	Static with fan	R290	185	-2 ~ +8	-	2	3	115	
	STF 600 TNM (New)	600x700x1950	500x540x1380	600	Static with fan	R134a	230	-5 ~ +5	-	2	3	82	
	GN 680 TNM	680x810x2010	564x682x1394	680	Ventilated	R290	210	-2 ~ +8	GN 2/1	2	3	115	
	GN 680 TNM (New)	680x810x2010	560x680x1390	680	Ventilated	R600a	225	-2 ~ +8	GN 2/1	2	3	121	
	STF 1210 TNM	1200x700x1950	1100x540x1380	1210	Static with fan	R134a	400	-5 ~ +5	-	4	6	115	
	G 1210 TNM	1200x740x1950	1100x540x1380	1210	Ventilated	R 134a	408	2 ~ +10	-	4	6	132	
Reach In Freezers	GN 1340 TNM	1340x810x2010	1224x682x1394	1340	Ventilated	R290	430	-2 ~ +8	GN 2/1	4	6	167	
	GN 1340 TNM (New)	1340x810x2010	1220x680x1390	1340	Ventilated	R290	415	-2 ~ +8	GN 2/1	4	6	170	
	STF 550 BTM	680x760x1965	560x590x1380	550	Static with fan	R134a	240	0 ~ -18	-	2	3	75	
	G 600 BTM	680x710x2010	564x582x1394	600	Ventilated	R290	465	-22 ~ -18	-	2	3	126	
	G 600 BTM (New)	680x710x2010	560x580x1390	600	Ventilated	R290	327	-18 ~ -22	-	2	4	118	
	STF 600 BTM	680x710x2010	564x582x1394	600	Static with fan	R290	435	-20 ~ -15	-	2	3	155	
	STF 600 BTM (New)	600x700x1950	500x540x1380	600	Static with fan	R134a	300	-18 ~ -12	-	2	3	84	
	GN 680 BTM	680x810x2010	564x682x1394	680	Ventilated	R290	465	-22 ~ -18	GN 2/1	2	3	126	
	GN 680 BTM (New)	680x810x2010	560x680x1390	680	Ventilated	R290	327	-18 ~ -22	GN 2/1	2	3	131	
	STF 1100 BTM	1220x760x1965	1100x590x1380	1100	Static with fan	R404a	380	0 ~ -18	-	4	6	145	
Double Temperature Reach In Cabinet	STF 1200 BTM	1340x710x2010	1224x582x1394	1200	Static with fan	R290	626	-20 ~ -15	-	4	6	155	
	G 1210 BTM	1200x740x1950	1100x540x1380	1210	Ventilated	R 404a	741	-22 ~ -17	-	4	6	132	
	GN 1340 BTM	1340x810x2010	1224x682x1394	1340	Ventilated	R290	730	-22 ~ -18	GN 2/1	4	6	177	
	GN 1340 BTM (New)	1340x810x2010	1220x680x1390	1340	Ventilated	R290	800	-18 ~ -22	GN 2/1	4	6	180	
	STF 550 DT-M	615x760x2005		550	Static with fan	R134a, R404a	330	0 ~ +8, -12 ~ -18	-	2	4	73	
	STF 1100 DT-M	1230x760x2005		1100	Static with fan	R134a, R404a	560	0 ~ +8, -12 ~ -18	-	4	6	130	
	STF 1200 DT-M	1200x700x1950	525x540x1380 (x2)	1200	Static with fan	R134a	500	-18 ~ -12/-5 ~ +5	-	4	6	135	
	Reach In Refrigerators with Glass Door	STF 600 TNG	600x700x1950	500x540x1380	600	Static with fan	R 134a	220	2 ~ +10	-	1	3	82
		GN 740 TNG	740*830*2010	-	700	Ventilated	R 134a		2 ~ +10	GN 2/1	1	3	
		GN 740 BTG	740*830*2010	-	700	Ventilated	R 134a		-15 ~ -18	GN 2/1	1	3	
GN 1410 BTG		1480x830x2010	1364x702x1401	1276	Ventilated	R290	865	-18 ~ -15	GN 2/1	2	6	232	
GN 1410 TNG		1480x830x2010	1364x702x1401	1276	Ventilated	R290	415	+2 ~ +8	GN 2/1	2	6	208	
Undercounter Refrigerators	S 901	900x700x850	830x595x455	240	Static with fan	R600a	170	+2 ~ +8	GN 1/1 Shelf per door	2	2	81	
	STF 2100 TN (New)	1200x700x837	800x529x582	270	Static with fan	R134a	300	-5 ~ +5	-	2	4	83	
	STF 2101 TN	1360x600x850	799x480x564	228	Static with fan	R290	255	-2 ~ +8	-	2	2	89	
	STF 3100TN	1800x650x800	1380x489x535	430	Static with fan	R134a	180	-5 ~ +10°C	-	3	3	100	
	STF 3101 TN	1795x600x850	1234x480x564	339	Static with fan	R290	275	-2 ~ +8	-	3	3	111	
	STF 3101 TN (New)	1800x700x800	1400x529x582	340	Static with fan	R134a	400	-5 ~ +5	-	3	6	107	
	G 2100 TN (New)	1360x600x860	902x430x560	228	Ventilated	R600a	275	-2 ~ +8	-	2	2	94	
	GN 2100 TN (New)	1360x700x860	902x530x560	282	Ventilated	R600a	275	-2 ~ +8	GN1/1	2	2	92	
	G 3100 TN (New)	1795x600x860	1337x430x560	339	Ventilated	R600a	275	-2 ~ +8	-	3	3	127	
	GN 3100 TN (New)	1795x700x860	1337x530x560	417	Ventilated	R600a	275	-2 ~ +8	GN1/1	3	3	114	
Undercounter Freezers	G 2100BT	1360x600x850	799x480x564	228	Ventilated	R290	520	-22 ~ -18	-	2	2	107	
	G 2100BT (New)	1360x600x860	902x430x560	228	Ventilated	R290	675	-18 ~ -22	-	2	2	95	
	GN 2100BT	1360x700x850	799x580x564	282	Ventilated	R290	520	-22 ~ -18	GN1/1	2	2	107	
	G 3100BT (New)	1795x600x860	1337x430x560	339	Ventilated	R290	675	-18 ~ -22	-	3	3	129	
	GN 3100BT	1795x700x850	-	417	Ventilated	R404a	620	-10 ~ -20	GN1/1	3	3	117	
	GN 3100 BT (New)	1795x700x860	1337x530x560	417	Ventilated	R290	675	-18 ~ -22	GN1/1	3	3	124	
Saladette	S 900	900x700x876	830x595x455	240	Static with fan	R600a	170	+2 ~ +8	GN 1/1 Shelf per door	2	2	81	
	S 903 (New)	1365x700x875	1295x595x500	368	Static	R290	435	+2 ~ +10	GN 1/1 Shelf per door	3	3	104	
Refrigerated Chef Tables/Drawers	CT 36	925x815x650	-	134	Ventilated	R134a	363	+3 ~ +10	YES	2	-	100	
Preparation Counters	SH 2000/800 (New)	1510x800x1085	1052x630x560	390	Ventilated	R290	340	-2 ~ +8	-	2	2	138	
	SH 3000/800	2025x800x1070	1605x584x586	650	Ventilated	R134a	360	-2 ~ +10	-	3	3	160	
	SH 3000/800 (New)	2020x800x1085	1052x630x560	580	Ventilated	R290	360	-2 ~ +8	-	3	3	180	
	PS 200 (NEW)	900x700x970	830x595x510	240	Static	R134a	300	+2 ~ +10	GN 1/1 Shelf per door	2	4	68	
	PS 300	1365x700x970	1295x595x455	392	Static with fan	R290	240	+2 ~ +8	GN 1/1 Shelf per door	3	3	104	
Countertop Display	VRX 1200 (Glass)	1200x335x435	-	-	Static	R134a	115	+2 ~ +10	GN 1/4	-	-	-	
Countertop Sushi Display	CTSS-5	1200*335*430	-	52	Static	R134a	135	+2 ~ +10	#	-	-	60	

Electricals: 220V/50Hz/1 Phase Specifications are subject to change without prior notice due to continuous product development # Please refer to information given next to the product picture.



Trufrost Blast Chillers/Freezers

The Trufrost Blast Chiller / Freezer is a revolutionary appliance which rapidly lowers the core temperature of foods (chilling from +90°C to +3°C in 90 minutes, freezing from +90°C to -18°C in 240 minutes), thus allowing perfect preservation and eliminating bacterial growth. It is an ideal appliance for chefs, pastry chefs and ice cream makers who need reliability, convenience and improved efficiency, without compromising on food quality.

Benefits of using a Blast Chiller/Freezer

- ◆ Reduce deterioration of products during the freezing process
- ◆ Increase the shelf life of the food product
- ◆ Maintain food quality including flavour, texture, colour, aroma and nutrients
- ◆ Save money making use of seasonal and bulk offers
- ◆ Save labour by enabling larger batch production
- ◆ Reduce waste of unwanted products and preserve for later use
- ◆ Enables preparation and storage during less busy periods



BCF-5
Yield per cycle 20 kg



BCF-10
Yield per cycle 40 kg



BCF-13
Yield per cycle 60 kg

Blast Chilling from +90°C to +3°C in 90 minutes

This process helps lower the food temperature to safe +3°C in a suitably short time, in line with HACCP standards. The adequate chilling speed helps reduce bacteria growth in the range from +65°C to +10°C. Blast chilling helps retain the quality, colour and smells of food and extends the storage period.

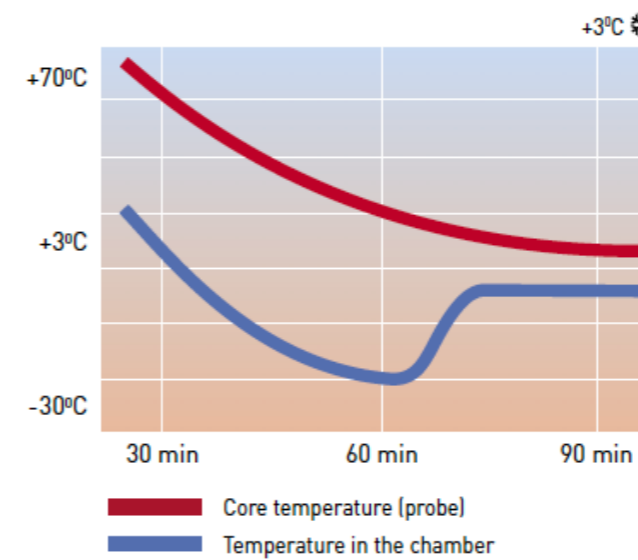

Shock Freezing from +90°C to -18°C in 4 hours

Blast freezing results in a large number of small crystals preserving the original properties of food: flavour, colour, texture and nutrients, and helps extend the storage period. This enables you to store the foods ready for thaw, regeneration and service for up to several months. Blast freezing can also be applied for raw materials and semi-cooked foods.

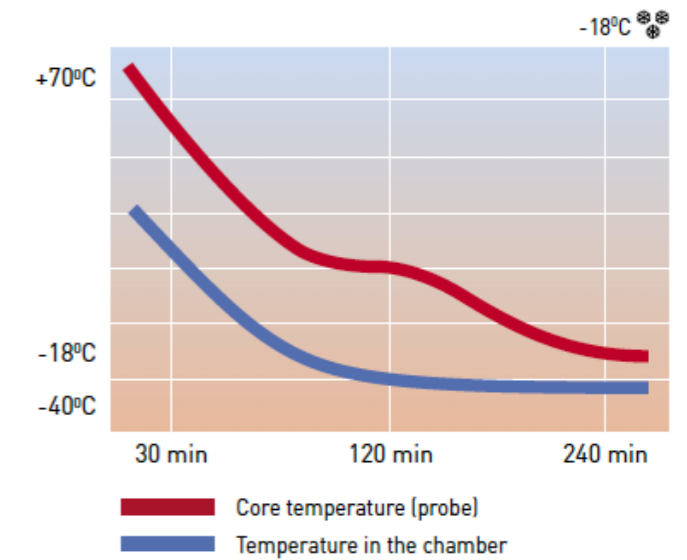

What can you blast freeze?

A great benefit of blast freezing is the variety of goods you can prepare and freeze in advance. You might be surprised at just how much you can store safely for weeks and months at a time. Below list is just some of the most popular food items caterers choose to blast freeze.



Raw & cooked meat, fish and poultry

Just like a regular domestic freezers, blast freezers are perfect for storing raw and cooked produce for use at a later date. A blast freezer can help to extend the life of meat, fish and poultry substantially whilst not compromising on flavour or food safety.

Fresh fruits & vegetables

Whole and pre-cut fruits and vegetables such as berries, chopped carrots, broccoli and peas are all suitable for blast freezing if stored correctly. They can be thawed to be eaten as is or added into soups, smoothies and other cooked meals.



Baked foods

Other helpful 'prepare ahead' items for caterers include breakfast pastries, pies, canopies and savouries. These popular buffet foods are often overlooked when it comes to freezing ahead. Like other foods, bakery produce will freeze best if stored correctly.

Ready meals

Blast freezers are useful to help store full, ready cooked meals ahead of time, and are handy when serving large volumes, daily. Blast freezing ready meals is particularly useful for catering in industrial canteens, schools or hospitals, as you can freeze and thaw full meals without losing that all-important nutritional content.



Ice Cream

When ice cream comes out of the batch freezer, you need to bring its temperature down to -14°C for display or -18°C for storage. Shock freezing brings it to -18°C in the shortest possible time. Free water turns into micro-crystals, which preserve the product, preventing changes to its quality, consistency, texture and allows your ice cream to maintain its 'overrun'.

Use of Blast Chiller /Freezer in various applications



Benefits of using a Blast Chiller /Freezer

- ◆ Reduce deterioration of products during the freezing process
- ◆ Increase the shelf life of the food product
- ◆ Maintain food quality including flavour, texture, colour, aroma and nutrients
- ◆ Save money making use of seasonal and bulk offers
- ◆ Save labour by enabling larger batch production
- ◆ Reduce waste of unwanted products and preserve for later use
- ◆ Enables preparation and storage during less busy periods

Technical Specifications



Model	Cooling System	Dimensions W*D*H (mm)	Pan Supports EN & GN 1/1		Chilling Capacity +70°C to +3°C	Freezing Capacity +70°C to -18°C	Refrigerant	Input Power (W)
			40mm deep	65mm deep				
BCF-5	Ventilated	800*800*990	5	3	20kgs in 90mins	15kgs in 240mins	R404a	760
BCF-10	Ventilated	800*800*1520	10	7	40kgs in 90mins	28kgs in 240mins	R404a	1500
BCF-13	Ventilated	800*800*1780	13	9	60kgs in 90mins	38kgs in 240mins	R404a	1860

Electricals: 220V/50Hz/Single Phase

Pans not supplied with machine

Specifications are subject to change without prior notice due to continuous product development



Roll-in Blast Chillers/Freezers

Our roll-in range of blast freezers for trolleys are designed to address the needs of medium to large-scale food preparation areas, from restaurant kitchens to semi-industrial bread and pastry manufacturers.

Built entirely in AISI 304 stainless steel, these blast freezers come with touch-screen controls. They are fitted with insulated floor with ramps for trolleys and high-performance condensing units. Their modular construction design allows easy transportation and flexible installation.

Key Features: Roll-ins

- Choice of Blast Chiller /Freezer models (90kg to 320kg) to accommodate 2/1 GN size trolley (Trolley is not included)
- Foodsafe 304 grade stainless steel exterior and interior
- Easy to use, control panel with LED Display
- Cam-lock modular panels allow the ease of on-site installation and disassembly for delivery
- Advanced airflow design enabling uniform freezing
- Easy to access evaporator for servicing and maintenance
- Automatically switches to storage mode at the end of each cycle before transfer to appropriate storage cabinet
- Removable balloon type magnetic door gasket for ease of cleaning & replacement
- Environmental-friendly CFC-free refrigerant (R404a)



At the heart of good spirits

Trufrost Ice Machines are built around the Trufrost brand promise: best-in-class manufacturing, a wide variety of ice production & storage capacities and above all, reliability. Trufrost Ice Cube Machines and Flake Ice Machines come in capacities ranging from 25 kg to 1000 kg per day and are ideal for use in hotels, restaurants, fast food outlets, bars, coffee shops, clubs, convenience stores, healthcare applications and more.



Why invest in an ice machine?



Food safety

Today's demanding food service professionals recognize that ice is a food product and therefore needs to be accorded its due in terms of food safety. All that you need is a good quality water connection and our ice machines take care of the rest.



Simple to use and maintain

Trufrost Ice Maker is simple to use, easy to maintain and quite durable. Just connect your ice-maker to a water inlet or insert a bottled water jar (in case of IC 50BW), turn the machine on, and you can begin to enjoy perfect ice within minutes. Designed to automatically turn off when the storage bin is full, they ensure a high level of energy efficiency.



Savings

Those in the hospitality and food service business would know that buying ice is not only unreliable from a food safety perspective but also more expensive in the long run. Moreover, your sales and profits go up, the more ice you use in your cold beverages.

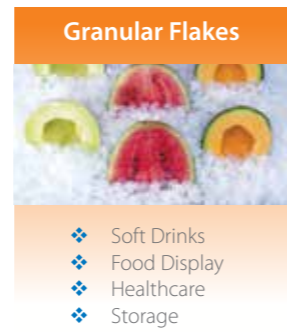
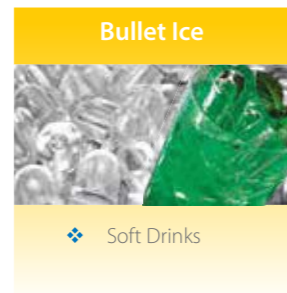
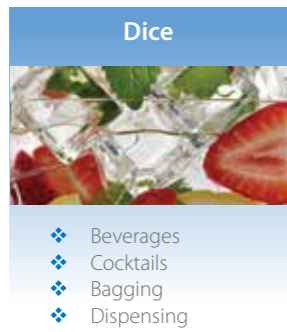

Ice Makers with Built-In Storage Bin

Highly relevant for commercial outlets where space is at a premium, the self contained Trufrost Ice Machines present the best options for bars, coffee shops and restaurants and can also be used for undercounter applications.

- Contemporary, elegant design available in ice production capacities ranging from 18 to 95 kg per day.
- Insulated ice storage bin and door minimize air condensation and water formation.
- IC 18BW also comes with a cold water dispensing option
- IC 35BWA & IC 50BWA models have the option of accommodating a bottled water jar on top



IC-18BW



IC-35BWA, IC-50BWA



IC-100

Modular Ice Machines

Modular ice machines need separate storage bins. Trufrost modular ice machines come with a vertical evaporator and are specially designed for large scale usage such as fast foods, discos, hotels and bars. They combine maximum energy yield whilst ensuring low investments and operating costs.

- Modular Ice Machines with high production capacity (190 to 900 kg per day).
- Low energy consumption
- Low water consumption per kg of ice produced
- Compatible Ice Storage Bins available separately at an extra cost.



IC-200
on ISB 105 Bin



IC-300, IC-455
on ISB 125 Bin



IC-900
on ISB 350 Bin

Selecting the appropriate storage bin for your ice machine

Trufrost Ice Storage Bins are perfectly insulated and specially designed to be compatible with Trufrost modular ice machines. Please refer to the technical specifications table to find out the storage bin compatible with each model.

Getting the most out of your ice machine

- For best performance in air-cooled machines, please allow for a minimum of 15 cm on both sides of the machine for air circulation.
- Please also provide enough space at the back of the machine for electrical and water connections.
- Please provide good quality potable water at the inlet of the ice machine. This will result in crystal clear, eye catching ice cubes and prevent the ice machine from accumulating scale.
- The cooler the temperature of the inlet water, the better would be the ice production efficiency of the machine.
- Do not install the ice maker near any heat source as it may impact the production capacity of the ice machine.



Flake Ice Machines

Flake ice is granular type of ice, perfect for display of fresh fish or for use by hotels for buffets for moisturising and cooling foodstuff to perfection. It is also perfect for use in research labs and bio-medical, life sciences and healthcare applications.

- ♦ Flake Machines with self contained bins in production capacities of 20 - 200 kg per day.
- ♦ Modular Ice Flake Machines with high production capacity (500 & 1000 kg per day).
- ♦ Low water and energy consumption.
- ♦ Compatible Ice Storage Bins available separately at an extra cost.



Ice Storage Bins

Trufrost Ice Storage Bins are perfectly insulated and specially designed to be compatible with Trufrost modular ice machines. They are made with special food grade material and come with an internal scoop holder that stays above ice line, enabling easy access and better sanitation.



Technical Specifications



Model	Rated Capacity / 24 hrs.*	Ice Storage Capacity	Cube Shape / Size	Refrigerant	Power (w)	Dimensions wxdxh (mm)	Compatible Storage Bin
IC 18 BW	18 kgs.	2.2 kgs.	Bullet / Ø 35*39 mm	R134a	-	357*423*452	-
IC 35 BWA	30 kgs.	15 kgs.	Dice / 28*28*23 mm	R404a	280	500*450*830	-
IC 50 BWA	50 kgs.	18 kgs.	Dice / 28*28*23 mm	R404a	320	500*590*830	-
IC 100	98 kgs.	36 kgs.	Dice / 28*28*22 mm	R404a	580	660*685*920	-
IC 200	192 kgs.	105 kg	Dice / 28*28*22 mm	R404a	1100	560*830*1718	ISB-105
IC 300	318 kgs.	125 kg	Dice / 28*28*22 mm	R404a	1420	760*830*1718	ISB-125
IC 455	455 kgs.	125 kg	Dice / 28*28*22 mm	R404a	2300	760*830*1893	ISB-125
IC 900	910 kgs.	350 kg	Dice / 28*28*22 mm	R404a	3800	1227*973*2048	ISB-350
IF 20	20 kgs.	10 kgs.	Granular Flakes	R 134a	280	330*470*605	-
IF 50	50 kgs.	15 kgs.	Granular Flakes	R 134a	380	400*540*700	-
IF 70	70 kgs.	25 kgs.	Granular Flakes	R 134a	460	400*510*845	-
IF 120	120 kgs.	40 kgs.	Granular Flakes	R 134a	550	500*611*950	-
IF 200	200 kgs.	60 kg	Granular Flakes	R134a	1040	650*740*1100	-
IF 500	500 kgs.	125 kg	Granular Flakes	R404a	2000	760*830*1950	ISB 125
IF 1000	1000 kgs.	315 kg	Granular Flakes	R404a	4000	1227*973*2195	ISB 350

* At 10°C incoming water and 10°C air temperature Electricals: 220V/50Hz/Single Phase
Height & width for IC 200/300/455/900 and IF 500/1000 is with the suggested storage bin
Specifications are subject to change without prior notice due to continuous product development

Specifications - Storage Bins

Model	Ice Storage Capacity	Dimensions wxdxh (mm)	Compatible with
ISB-105	105 kgs.	560*830*1150	IC-200
ISB-125	125 kgs.	760*830*1150	IC-300, IC-455, IF-500
ISB-350	350 kgs.	1227*973*1255	IC-900, IF-1000

We just raised the bar



Wine Storage - why a normal refrigerator wouldn't do?

If you are a collector of vintage wines and use your refrigerator to store them, you might have already been compromising with the quality of your wines. Normal refrigerators are not designed for wine storage – not only in terms of the temperature they need but also due to lack of UV protection, humidity, vibration control and even the ventilation that is so important for wines. Incorrect warming or cooling can play havoc with the wine's aroma.



Recommended serving temperatures for different wines

Wine should always be enjoyed at the right temperature. As a general rule, red wine is best served at a temperature between 12°C and 18°C, depending on the origin, grape and year. White wine is best served between 8°C and 12°C. Champagne and fruity dessert wine should be served ice cold, between 5°C and 7°C.

White wines
8°C to 12°C

Red wines
12°C to 18°C

Sparkling wines
5°C to 7°C



Trufrost Wine Coolers

Wines develop their full flavour when they are stored in the right conditions and served at the right temperature. Trufrost wine coolers ensure that. They create the perfect conditions for optimal storage of all types of wines – be it red, white or sparkling. You can choose among 4 different models with single, double and three temperature zone options.



3 Temperature Zones

W 133 TZ

Ideal for a large assortment of wine collection with 3 separate compartments for your reds, whites and champagnes. It can store up to 133 bottles of 0.75 litres.



2 Temperature Zones

W 100 DZ

Ideal for a large variety of wine collection with two separate compartments for your reds and whites that can store up to 100 bottles of 0.75 litres.



2 Temperature Zones

W 30 DZ

This dual temperature zone cabinet comes with two separate compartments for your reds and whites that can store up to 30 bottles of 0.75 litres - 15 bottles in each compartment.



1 Temperature Zone

W 18 SZ

This single temperature zone wine cabinet can be set at a mid-point temperature so as to cater to the storage needs of different wines and can store up to 18 bottles.

Technical Specifications



Specificatio	W 133 TZ	W 100 DZ	W 30 DZ	W 18 SZ
Bottle Storage (0.75 ltr)	Upper Zone: 44 Middle Zone: 44 Lower Zone: 45	Upper Zone: 44 Lower Zone: 56	Upper Zone: 15 Lower Zone: 15	18
Storage Volume (litres)	405	308	93	68
Dimensions (w*d*h) (mm)	598*685*1815	598*685*1403	380*610*890	453*512*715
Temperature Range	Upper Zone 5-15°C Middle Zone 5-15°C Lower Zone 7-18°C	Upper Zone 5-15°C Lower Zone 7-18°C	Upper Zone 5-15°C Lower Zone 7-18°C	5-18°C
Temperature Zones	Three	Dual	Dual	Single
Power (w)	200w	200w	190w	60W
Digital Temperature Indicator	Yes	Yes	Yes	Yes
Lock	Yes	Yes	Yes	No
Glass Door	2 layered tempered brown	2 layered tempered brown	2 layered tempered brown	2 layered tempered brown
Door Handle	Steel	Steel	Steel	Steel
No. of beech wood shelves	Sliding x 12 + Display x 1	Sliding x 9 + Display x 1	Sliding x 6	Storage x 4
Refrigerant	R 600a	R 600a	R 600a	R 600a
Cabinet Case & Interior	Black	Black	Black	Black
Lighting under each shelf	Blue LED	Blue LED	Blue LED	Blue LED

Electricals: 220V/50Hz/1 Phase

Specifications are subject to change without prior notice due to continuous product development

Distinctive Features of Trufrost Wine Coolers

Full glass door with elegant black border

Digital temperature controller with display

Stylish Blue LED under each shelf

Double tempered brown glass with UV protection

Air intake and exhaust from the front allowing built-in applications



Ball bearing track for easy sliding

Beechwood shelves

Stainless Steel Handle

Dual Temperature Zones

Black cabinet and interiors

Lock

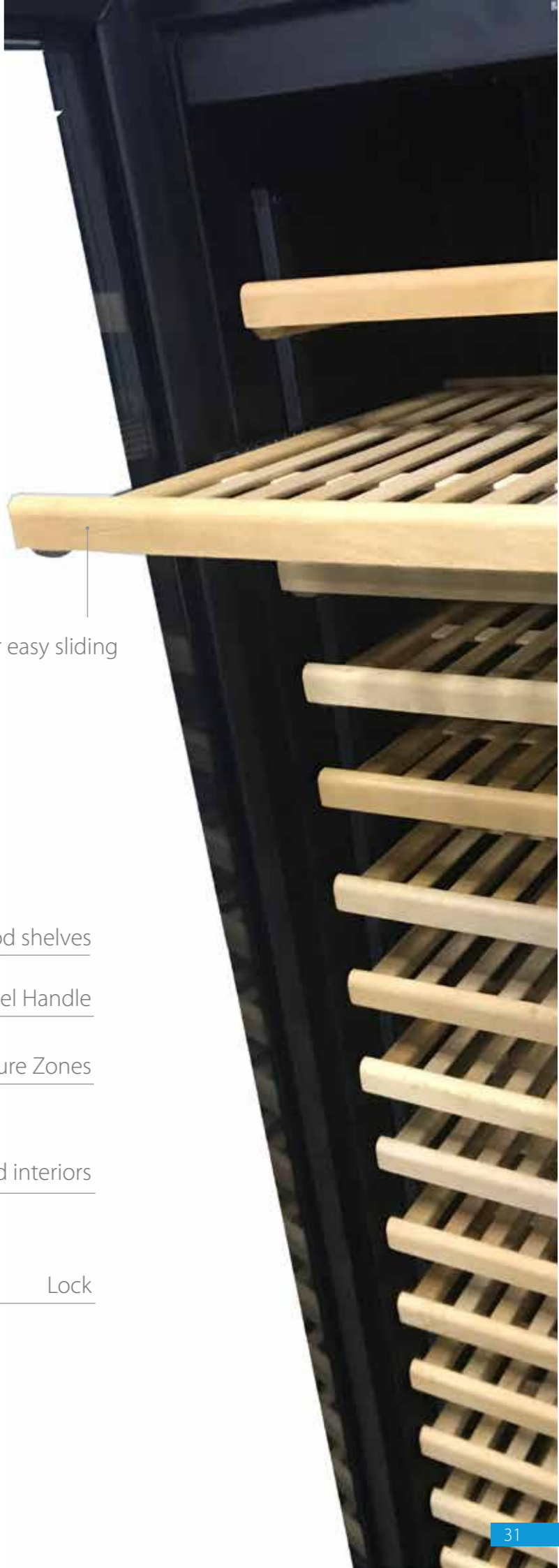



Visi Coolers

Trufrost Bottle Coolers are designed to chill products quickly, even when the frequency of door openings is high. Fitted with 2 LED lights, they provide an attractive view of the displayed bottles & cans and allow rapid restocking & cooling.

Undercounters in stainless steel

Elegant yet reliable, Trufrost Undercounter Back Bars are made in solid stainless steel and are ergonomically designed to enhance the efficiency of professional bartenders. They are perfect for showcasing bottled and canned beverages.



Back Bars

Trufrost Back Bars come in two options - one in stunning black coloured body and matching door frame and the other in stainless steel exterior. They provide an attractive view of the displayed items – be it bottles or cans. Available in 1, 2 and 3 door options.

Technical Specifications



Specification	Black Bottle Coolers		Back Bars			Back Bars in Stainless Steel		Glass Door Undercounters		Glass Door Undercounters		Glass Froster
	VC-320	VC-400	BB-100	BB-200	BB-300	BB-200SS	BB-300SS	G 2100 TNG	G 3100 TNG	GN 2100 TNG	GN 3100 TNG	GF 201 SS
Gross Volume (Litres)	280	350	100	200	300	200	300	252	380	282	417	200
w*d*h (mm)	545*620*1727	600*665*1877	600*505*895	900*505*865	1335*505*865	900*505*865	1335*505*865	1360*600*860	1795*600*860	1360*700*860	1795*700*860	595*628*830
Temperature Range	0-10°C	0-10°C	2-10°C	2-10°C	2-10°C	2-10°C	2-10°C	2-8°C	2-8°C	2-8°C	2-8°C	-18 ~ -22°C
Power (W)	170	170	250	280	350	280	350	350	350	350	350	130
Lock	Yes	Yes	Yes	Yes	Yes	Yes	Yes	No	No	Yes	Yes	Yes
Defrost	Automatic	Automatic	Automatic	Automatic	Automatic	Automatic	Automatic	Automatic	Automatic	Automatic	Automatic	Manual
No. of Doors	1	1	1	2	3	2	3	2	3	2	3	1
No. of shelves	4	5	2	2	2	2	2	2	3	2	3	2
Refrigerant	R 134a	R 134a	R 134a	R 134a	R 134a	R 134a	R 134a	R 134a	R 134a	R 134a	R 134a	R 134a
Interior Light	Yes / 2 LEDs	Yes / 2 LEDs	Yes	Yes	Yes	Yes	Yes	Yes	Yes	Yes	Yes	Yes
Wheels / Castors	Yes	Yes	No	No	No	No	No	Yes	Yes	Yes	Yes	No

Electricals: 220V/50Hz/1 Phase

Specifications are subject to change without prior notice due to continuous product development



Draught Beer Systems

When handled properly from brewery to bar to glass, draught beer delivers what many consider to be the freshest, most flavorful beer available to the customer. We find draught taps so often that we assume it must be relatively simple to keep and serve beer this way. But behind the simple flick of a handle that sends beer streaming into our glass at the bar, there is an alignment of the dispense variables and consistent housekeeping practices. Trufrost Draught Beer Systems are meticulously designed for exact operating conditions, and regular maintenance to ensure the proper flow of high-quality beer.

Essential Components of Draught System

Beer Coolers

Our cooling systems hold beer at a constant temperature from keg to glass and prevent any increase in beer temperature between the cooler and the faucet that can lead to dispensing problems such as foaming. The drinks are carried - via thermally insulated plastic tubes - from the external environment to the dispensing tower. The insulating tube (known as the "python") and the dispensing tower are not included with the machine. You have the option of choosing between countertop coolers, undercounter coolers.



Draught Beer Systems comprise of three sub-systems: gas, beer, and cooling

Gas

Draught systems use CO2 alone or mixed with nitrogen in varying proportions depending on the requirements of the system and the beers being served. When properly selected and set, dispense gas maintains the correct carbonation in the beer and helps to preserve its flavor. In most draught systems, the dispense gas also propels beer from the keg to the faucet. Because the dispense gas comes into direct contact with the beer, it must meet strict criteria for purity.

Beer

Most draught systems use the gases mentioned above to drive beer from the keg, through tubing and to the faucet where it will flow into the customer's glass. During the journey from keg to glass, we want to protect the beer from anything that would compromise its flavor or alter the carbonation created by the brewery. The beer should flow through well maintained proper beer lines and avoid any contact with brass parts that would impart a metallic flavor. We also want the beer to flow at a specific rate and arrive with the ideal carbonation level.

Cooling

The cooling system should hold beer at a constant temperature from keg to glass. Any increase in beer temperature between the cooler and the faucet can lead to dispense problems such as foaming. In a simple direct-draw system, a refrigerated cabinet maintains the temperature of the keg and provides cooling to the beer as it travels the short distance to the faucet. Many long-draw systems use a walk-in refrigerator to cool the kegs, plus chilled glycol that circulates in tubes next to the beer lines all the way to the faucet, to ensure that the beer stays cold all the way to the glass.

Counter Top Beer Coolers



CTB-1, CTB-2

Under Counter Beer Coolers



UBC-100, UBC-150

Mobile Coolers



MBC-2

Kegeators



UDD-1, UDD-24-60SS

Technical Specifications



Model No.	Dispensing Capacity (L)	Water Tank (Litres)	w x d x h (mm)	Temperature Range	Power (w)	Compressor Power (Hp)	Ice bank (kg)	Pumping Capacity (L/H)	Water Pump Head (m)	Net Weight	Refrigerant	Max Taps
CTB-1	40	14	430x420x290	3 -7°C	220	1/4 HP	7-9,	-	-	21	R - 134 A	1
CTB-2	40	14	430x420x290	3 -7°C	220	1/4 HP	7-9,	-	-	23	R - 134 A	2
UBC - 100	90/100	40	480x460x680	3 -7°C	350-400	1/4 HP, 1/3 HP	15-18, 17-19	780	6.5	30-35	R - 134 A	1-4,
UBC - 150	150	55	480x490x720	3 -7°C	410	1/3+ HP	24-26,	780	6.5	42-46	R - 134 A	1-8,
MBC - 2	200	70	80x560x900	3 -7°C	430	1/3+ HP	30-38,	780	6.5	45-48	R - 134 A	2

Model No.	Doors	Capacity (Litres)	Dimensions w x d x h (mm)	Temperature Range	Compressor Power (Hp)	KEG Capacity 50 Liters	KEG Capacity 20 Liters	Refrigerant	Max Taps
UDD - 1	1	186	596x772x983	0.5°C-3.3°C	1/6 HP	1	2	R - 134 A	1
UDD - 24 -60 SS	2	446	1544x620x905	0°C-5°C	1/3+ HP	2	6	R - 134 A	2

Electricals: 220V/50Hz

Specifications are subject to change without prior notice due to continuous product development

A photograph of two glasses filled with bright orange sorbet, each garnished with a small sprig of fresh green mint. The glasses are placed on a rustic, light-colored wooden board. In the background, a white ceramic spoon and a small white bowl are visible on a light-colored, textured surface. The overall scene is bright and clean, suggesting a fresh and healthy treat.

Turn your business
into the **fast lane**

Trufrost presents a truly world class range of dispensers designed to help scale up the sales and profitability of ice cream parlours, frozen yogurt outlets, convenience stores, coffee shops, clubs, food courts, kiosks, canteens and a wide variety of small and medium sized stores.

Soft Serve Freezers

With a Trufrost freezer, it is easy to make soft ice cream and frozen yogurt. Just add the pre-mix from your chosen dairy or premix supplier, freeze it down and in few minutes, you are ready to serve. Trufrost freezers produce consistent quality, draw after draw. The countertop models are designed to dispense a single flavour for light duty applications.



Solo

Solo Plus

2 Plus 1, 2 Plus 1 HD

CE

Model	Flavours	Max. production	Mix Hopper capacity	Freezing cylinder capacity (Litres)	W x D x H (mm)	First Dispensing	Consecutive Dispensing (Cups)	Rated Input Power
Solo	1	10 Litres/Hr.	4 Litres x 1	1.5 x 1	220x660x660	13 minutes	5	700 W
Solo Plus	1	16 Litres/Hr.	5.5 Litres x 1	1.5 x 1	340x670x725	10 minutes	5	1500 W
2 Plus 1	Twin Twist	25 Litres/Hr.	5.5 Litres x 2	1.75 x 2	540x710x1440	9 minutes	5	2500 W
2 Plus 1 HD	Twin Twist	32 Litres/Hr.	9 Litres x 2	1.9 x 2	540x710x1440	8 minutes	7	3000 W

Data based on ambient temperature of 32°C

Electricals: 220V/50Hz/1 Phase

Specifications are subject to change without prior notice due to continuous product development

Ice Cream & Gelato Batch Freezers

Trufrost Batch Freezers provide you the convenience of making your own signature ice creams, gelato and a wide variety of premium desserts from one easy to use machine. Serve homemade ice cream, sorbet or Italian ice. Fruits, nuts and candies can be folded in as the product is being drawn into your container.



GBF-10



GBF-20

CE

Model	W x D x H (mm)	Freezing Cylinder	Max Production	Refrigerant	Rated Input Power	Drive Motor	Weight
GBF-10	596 x 530 x 400	4.7 L	10L / hr	R 134a	800w	1.375 HP	50 Kg
GBF-20	455 x 710 x 755	5.4 L	20L / hr	R 404a	2000w	1.5 HP	100 Kg

Electricals: 220V/50Hz/1 Phase

Specifications are subject to change without prior notice due to continuous product development





Frozen Drink Dispensers

Compact dispensers for Granita/Slush and other frozen drinks such as sorbets, yogurts, cocktails, frozen coffee & cappuccino. Their visual display assists in more sales. You can choose between models that have 1 or 2 bowls and come in 3 litre or 6 litre variants as reflected in the table below. They come with an unbreakable, transparent, easy to clean, food-grade bowl and thermostats for soft drink mode and for overnight storage.



Quark 2



B3.1 ETC



JJ-12



Turia 19

Model	W x D x H (mm)	No. of bowls
B3.1 ETC	180 x 510 x 470	1 x 3L
Quark 2	360 x 470 x 650	2 x 6L

Electricals: 220V/50Hz/1 Phase
Specifications are subject to change without prior notice due to continuous product development



Multipurpose Dispensers

Versatile counter top models for the cooling and dispensing of a variety of popular Indian drinks such as Jal Jeera, Buttermilk, Lassi, Aam (mango) Panna & other natural juices with light pulp. You can choose between two models that come in 12 and 19 litre capacities. The paddle is designed to stir the beverages and prevent any sedimentation and the machines are easy to clean and sanitize.



Chach/ Buttermilk Jal Jeera Sweet Lassi Aam Panna

Model	W x D x H (mm)	Bowl capacity
JJ-12	220x660x660	12 litres
Turia 19	320x400x700	19 litres

Electricals: 220V/50Hz/1 Phase
Specifications are subject to change without prior notice due to continuous product development



Juice Dispensers

These Trufrost dispensers are ideal for non-carbonated beverages, built with an energy efficient refrigeration system, they are easy & quick to dismantle and clean. They come with a shock proof, non-toxic polycarbonate bowls of 8 litres. capacity with independent mixing control. JD-8.2 comes with a spray mechanism that creates a fountain effect and is suitable for syrup based, watery juices whereas Jolly-8.2 comes with an impeller and can adapt to cold teas and milky drinks also. Both are however not recommended for pulp based drinks which are better dispensed in our models JJ-12 or Turia 19 shown ahead.



Jolly-8.2



JD-8.2



Model	W x D x H (mm)	No. of bowls
Jolly 8.2P	250 x 400 x 630	2
JD-8.2	290 x 400 x 680	2

Electricals: 220V/50Hz/1 Phase
Specifications are subject to change without prior notice due to continuous product development

Hot Chocolate Dispensers

Hot chocolate as a menu option has gained preference in ice cream parlours and cafes, across the world. This elegant countertop dispenser from Trufrost is specially suited for the mixing and dispensing of thick chocolate and other hot drinks. Beverage container made of shock proof, food grade polycarbonate with 3 litre capacity that is completely removable even when full of product. They come with a removable faucet for easy cleaning, an adjustable thermostat, an overhold protector and a noise level less than 70 db(A).



Scirocco 3

Model	W x D x H (mm)	Bowl capacity
Scirocco 3	240x320x490	3 litres

Electricals: 220V/50Hz/1 Phase
Specifications are subject to change without prior notice due to continuous product development



Show off your
masterful creations in style



With Trufrost Display Cases you can virtually upgrade your food business to club class. These world class showcases are built using reliable cooling system, controllers and design elegance that Europe is known for. In short, these are designed to increase your sales... not your problems.

Why Trufrost confectionery showcases are miles ahead?

Help you save on food wastage:

If the display in your showcases looks anything like the showcase shown on the top right, it is time you looked for an upgrade to Trufrost. Our display cases come with an advanced, double tempered and heated front glass that enhances visibility and prevents unhygienic condensation as would be experienced in conventional display cases. This, coupled with a reliable ventilated refrigeration system and an auto defrost ensures uniform cooling which means that your food stuff – be it the Bengali mithais or exotic cheesecakes, can stay fresh, longer.

Aesthetics:

Trufrost display cases come in an elegant combination of black glass & stainless steel and contemporary LED lighting under each shelf that enhances the display giving a very classy, premium and an international feel to the ambience.

Conventional Display



Trufrost Display





Curved Glass Showcases

These classic showcases are all time favourites and are suitable for upscale refrigerated display and retail of Cakes, Pastries, Indian Desserts, Dairy Products, Beverages, Yogurts, Cold Cuts, Sandwiches etc. Ideal for Hotels, Coffee Shops, Cafes, Pastry Shops, Sweet Shops, Restaurants and more. You can choose between 2 models with options of 3 layers or 4 layers. The standard models come in 1200mm width.

Options for firm project orders booked with longer lead times:

- ◆ Choice of 900, 1500 or 1800 mm width
- ◆ Showcases with marble base in place of regular stainless steel
- ◆ Option of warm showcases



CS-43



CS-44



Flat Glass Showcases

The Flat Glass Showcases from Trufrost are a runaway success. They are absolutely stunning showcases and you can choose between 2 models with options of 3 layers or 4 layers. The standard models come in 1200mm and 1500 mm widths.

Options for firm project orders booked with longer lead times:

- ◆ Choice of 900 or 1800 mm width
- ◆ Showcases with marble base in place of regular stainless steel
- ◆ Option of warm showcases



CSF 43
WSF-43



CSF 44
WSF 44



Temptation 44
Temptation 44W

Temptation

This fashionable new product with an international appeal from the house of Trufrost has become an instant hit and a bestseller within a short span of time, since its launch. Its unique front glass is inclined dramatically to create an inviting and unhindered view of the displayed foodstuff. Moreover, it comes with a front heated glass that keeps the condensation away. You can also place multiple units next to each other to give a magical look to the store ambience. The standard models come in 1200mm width.

Options for firm project orders booked with longer lead times:

- ◆ Choice of 900, 1500 or 1800 mm width
- ◆ Option of warm showcases



Key Features - Floor Standing Displays

All our floor standing models - Flat Glass, Curved Glass and Temptation come with several distinguishing features such as:

- ◆ Double tempered & special heated front glass that enhances visibility and prevents unhygienic condensation
- ◆ Auto defrost
- ◆ Elegant combination of black glass & stainless steel
- ◆ Contemporary LED lighting under each shelf
- ◆ Ventilated refrigeration for uniform cooling
- ◆ Digital temperature controller & display
- ◆ Castors for easy mobility

Flat Glass Tall Showcases

This stunning new showcase from Trufrost stands tall and enables you to proudly display your delightful creations. It comes in a width of 5' (1500mm to be precise) and has 4 underlit shelves with LED lighting to enhance your cakes and bakes. The model can be paired well with our other models shown in the previous pages.



CSF-55 Tall





Crystal Tower

This show-stopper from Trufrost presents a 4 side panoramic view of your display enhanced by LED lighting and comes with a digital temperature display, chrome plated adjustable shelves, 4 castors and air duct to remove condensation on the glass. It is ideal for showcasing beverage bottles, canned drinks, packed savouries, cakes, pastries and more.



Key Features

- Panoramic 4 side double glass
- Digital temperature controller & display
- Elegant finish
- Ventilated cooling
- Chrome plated adjustable shelves
- Brilliant LED lighting
- Air duct outside the glass to remove condensation
- 4 Castors, 2 with breaks



the fashion statement

Diva

Inspired by the jewellery shop and high-end fashion boutiques, this jewellery box type display showcase from Trufrost is perfect for gorgeous creations especially, exotic pastries and chocolates. It has two refrigerated pull-out drawers at the rear and brilliant LED lighting to enhance the display. It also comes with an additional refrigerated storage underneath the drawers. You can place multiple units together to give a magical look to your store's ambience.



Diva



Pull-out Drawers



Countertop Cold Displays

Suitable for showcasing and retailing Cakes, Pastries, Indian Desserts, Dairy Products, Cold Cuts, Sandwiches and Beverages. You can choose between two models that come in a dazzling combination of steel & glass, and fitted with a reliable, bottom mounted cooling system.



CTR-23



CTSR-23



Mini Tower

Mini Tower

This stunning countertop cold display is suitable for showcasing and retailing Cakes, Pastries, Indian Desserts, Dairy Products, Cold Cuts, Sandwiches and Beverages. It comes in a dazzling combination of steel and glass, and is fitted with a reliable, bottom mounted cooling system.



Countertop Warm Displays

Suitable for showcasing and retailing a wide variety of appetizers and savouries like Samosas, Kachories, Patties, Wraps, Cutlets, Kathi Rolls and similar snacks. You can choose between 4 models that come in a dazzling combination of steel & glass. The model, CTW-4 is particularly suitable for displaying Halwas, Gulab Jamuns or similar Indian desserts that are served warm. FDW-3 is also suitable for displaying warm pizzas amongst other food items.



CTW-23



CTSW-23



CTW-4



FDW-3



Technical Specifications



Model	Product	No. of Layers		Dimensions W*D*H (mm)	Volume (Litres)	Temp. Range (°C)	Front Glass	Refrigerant	Power (Watts)
		No.	Description						
CS 43	Curved Glass 3 Layer Cake Showcase	3	Base + 2 shelves	1200*730*1200	459	2~8	Heated	R 134a	450
CS 44	Curved Glass 4 Layer Cake Showcase	4	Base + 3 shelves	1200*730*1300	530	2~8	Heated	R 134a	450
CSF 33	Flat Glass 3 Layer Cake Showcase	3	Base + 2 shelves	900*730*1200	390	2~8	Heated	R 134a	450
CSF 34	Flat Glass 4 Layer Cake Showcase	4	Base + 3 shelves	900*730*1300	390	2~8	Heated	R 134a	450
CSF 43	Flat Glass 3 Layer Cake Showcase	3	Base + 2 shelves	1200*730*1200	459	2~8	Heated	R 134a	450
CSF 44	Flat Glass 4 Layer Cake Showcase	4	Base + 3 shelves	1200*730*1300	530	2~8	Heated	R 134a	450
WSF 44	Flat Glass 4 Layer Warm Showcase	4	Base + 3 shelves	1200*730*1300	530	40-65	-	-	450
CSF 53	Flat Glass 3 Layer Cake Showcase	3	Base + 2 shelves	1500*730*1200	580	2~8	Heated	R 134a	450
CSF 54	Flat Glass 4 Layer Cake Showcase	4	Base + 3 shelves	1500*730*1300	670	2~8	Heated	R 134a	450
WSF 54	Flat Glass 4 Layer Warm Showcase	4	Base + 3 shelves	1500*730*1300	670	40-65	-	-	450
CSF 55 Tall	Flat Glass 4 Layer Warm Showcase	5	Base + 4 shelves	1500*720*1900	1400	2~10	Heated	R404a	1255
Temptation-44	Inclined Glass 4 Layer Cake Showcase	4	Base + 3 shelves	1200*730*1300	480	2~8	Heated	R 134a	450
Temptation-44W	Inclined Glass 4 Layer Warm Showcase	4	Base + 3 shelves	1200*730*1300	480	40-65	-	-	450
Crystal Tower	4 Side Glass Panoramic Cake Showcase	5	Base + 4 shelves	515*485*1895	280	2~12	Double Glass	R 134a	400
Diva	Chocolate & Confectionery Counter with Drawers	1	2 Pullout Drawers	900*850*1030	160	2~10	Heated #	R 134a	500
Mini Tower	Desk Top Tall Display Refrigerator	4	Base + 3 shelves	430*390*986	78	2~12	Double Glass	R 134a	180
CTR-23	Countertop 3 Layer Cake Showcase	3	Base + 2 shelves	660*530*730	68	2~8	-	R 134a	160
CTSR-23	Countertop 3 Layer Square Glass Cake Showcase	3	Base + 2 shelves	660*530*730	68	2~8	-	R 134a	160
CTW-23	Countertop 3 Layer Warm Showcase	3	Base + 2 shelves	660*530*730	68	40~65	-	-	450
CTSW-23	Countertop 3 Layer Square Glass Warm Showcase	3	Base + 2 shelves	660*530*730	68	40~65	-	-	450
CTW-4	Countertop Warm Display Case	1	4 x GN 1/3 pans	773*420*336	67	30~90	-	-	500
FDW-3	Food Display Warmer with 3 Shelves	3	3 shelves	400*448*785	97	30~90	-	-	800

Electricals: 220V/50Hz/Single Phase

Specifications are subject to change without prior notice due to continuous product development

Top glass also heated



Food Display Warmer with Humidity Control

Suitable for showcasing and retailing a wide variety of appetizers and savouries like Samosas, Kachories, Patties, Wraps, Cutlets, Kathi Rolls and similar snacks. Dazzling combination of steel & glass. FDW-4H is suitable for displaying warm pizzas amongst other food items.

- ◆ Digital temperature controller and display
- ◆ Rotational chrome plated shelves
- ◆ Adjustable humidity and heat control



FDW-4H

■ Suitable for displaying 18" pizzas

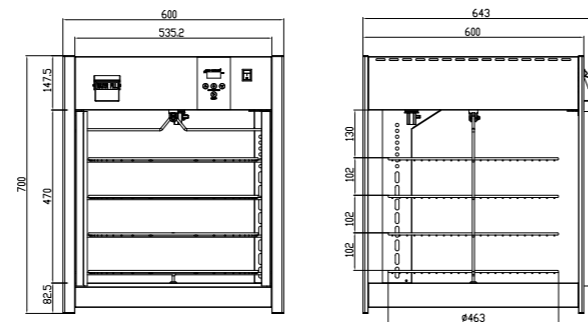

Technical Specifications



Model	Capacity (L)	Temperature Range	Power	Weight	Dimensions (W x D x H)	Electricals
FDW-4H	158	30-90°C	1700W	32 kgs.	600x642x700 mm	220V / 50 Hz/1Ph

Specifications are subject to change without prior notice due to continuous product development



Adding colours to food retail



Open Multideck Chillers – Remote

These positive temperature vertical open type refrigerated cabinets by Trufrost feature efficiency and high visibility, thanks to the integration of the most recent technological innovations with a sophisticated design. Ideal for packaged dairy products, beverages, packaged food, fruits & vegetables, and even certain meat & poultry items. Available in three widths, these models can be multiplexed together to create bespoke solutions. Remote systems are commonly the best solution for outlets looking to install a large number of chillers as they will keep noise and heat to a minimum within the store.



RMD-1935, RMD-2560, RMD-3810
Tesey Compact 250, Tesey Compact 375

Key Features

- ◆ Reliable and customised remote refrigeration
- ◆ Low front edge maximizes space for food display
- ◆ Optimised shelf depth enables more effective displayable volume
- ◆ Shelves can be tilted to 0°/10°/20°
- ◆ Top tubing design makes construction easier
- ◆ Ultra-wide night curtains minimize the gaps and also energy loss
- ◆ Off-cycle defrost reduces the energy consumption
- ◆ Option of CFC free refrigerant available

Line Drawing

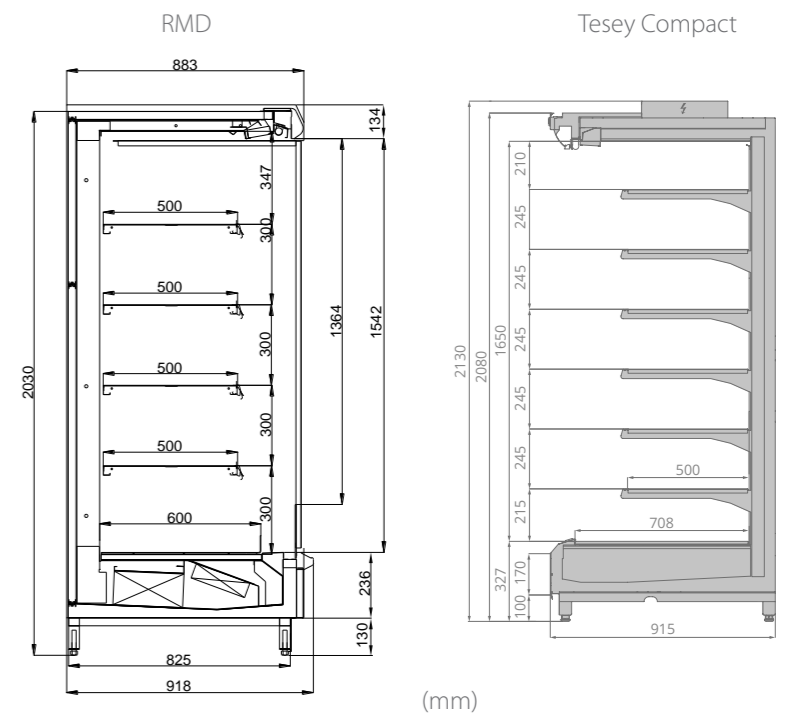

Technical Specifications - Remote Multideck Chillers



Model	Dimension (WxDxH)	Display Area (M ²)	Cooling System	Electricals	Temperature Range	Refrigerant	Cooling Capacity	Power	LED	Night Curtain
RMD-1935	1935x918x2030 mm	2.94	Ventilated	220V/50Hz/1 Ph	2°C ~ 6°C	R404a/R22	2.6KW	1.8KW	Yes	Yes
RMD-2560	2560x918x2030 mm	3.92	Ventilated	220V/50Hz/1 Ph	2°C ~ 6°C	R404a/R22	3.5KW	1.8KW	Yes	Yes
RMD-3810	3810x918x2030 mm	5.88	Ventilated	400V/50Hz/3 Ph	2°C ~ 6°C	R404a/R22	5.2KW	2.6KW	Yes	Yes

* The width mentioned above is inclusive of two end panels of 30mm each Shelves can be tilted to 0°/10°/20°
Specifications are subject to change without prior notice due to continuous product development

Technical Specifications - Tesey Compact Remote Multidecks Chillers



Model	Dimension (WxDxH)	Display Area (M ²)	Cooling System	Electricals	Temperature Range	Refrigerant	Cooling Capacity	Power	LED	Night Curtain
Tesey Compact-250	2570x915x2130	4.0	Ventilated	220V/50Hz/1Ph	2°C ~ 6°C	R404a/R22	3.5KW	2.4KW	Yes	Yes
Tesey Compact-375	3820x915x2130	6.0	Ventilated	400V/50Hz/3Ph*	2°C ~ 6°C	R404a/R22	4.6KW	4.5KW	Yes	Yes

* 220V/50Hz/1Ph available End panels thickness is 35mm Specifications are subject to change without prior notice due to continuous product development



Upright Vertical Freezers or Chillers – Remote

The upright 3, 4 and 5 door Freezers or Chillers from Trufrost are designed to respond to the increasingly dynamic needs for small surfaces and proximity stores. They combine the elegance and design of remote solutions with the flexibility of plug-ins.

Remote Glass Door Chillers & Freezers

The Remote Chillers and Freezers from Trufrost can be configured next to each other to give a uniform, pleasing look to the store ambience and are ideal for creating themed walls or corners. Available in 3,4 or 5 door variants.



VCR-2800
Chiller



VFR-2800
Freezer

Technical Specifications

Model	Dimensions (wxdxh)	Volume	Doors	Shelves	Temp. range	Refrigerant	Cooling Capacity	Power	Electricals
VCR-2000	2050x750x2000mm	2190L	3	18	+2°C ~ +6°C	R404a/R22	1150W	1.2kW	220V/50Hz/1Ph
VCR-2800	2734x750x2000mm	2955L	4	24	+2°C ~ +6°C	R404a/R22	1570W	1.4kW	220V/50Hz/1Ph
VCR-3500	3418x750x2000mm	3720L	5	30	+2°C ~ +6°C	R404a/R22	1750W	1.6kW	220V/50Hz/1Ph
VFR-2000	2050x750x2000mm	2080L	3	18	-18°C ~ -20°C	R404a	1200W	1.3kW	220V/50Hz/1Ph
VFR-2800	2734x750x2000mm	2820L	4	24	-18°C ~ -20°C	R404a	1750W	1.8kW	220V/50Hz/1Ph
VFR-3500	3418x750x2000mm	3560L	5	30	-18°C ~ -20°C	R404a	2200W	2.3kW	400V/50Hz./3Ph

Specifications are subject to change without prior notice due to continuous product development



Key Features

- ◆ Reliable and customised remote refrigeration
- ◆ Temperature range:
 - ◆ Chillers: +1 ~ +10°C
 - ◆ Freezers: -18 ~ -20°C
- ◆ Digital temperature control
- ◆ Automatic defrost for freezers
- ◆ Adjustable feet
- ◆ Interior LED light
- ◆ Self closing doors
- ◆ Triple pane glass with heat film for freezers

Plug-In Refrigerated Multidecks



Vento Plug-In Refrigerated Multidecks



Best solution for small stores

Trufrost Vento are a premium range of Plug-Ins manufactured in Europe. They are designed specifically for small stores looking to find a balance between the widest possible display amidst a tight retail space.

Making the most of the inside thanks to the deep shelves, Vento Plug-In makes more room for customers, with its space-effective outer dimensions and ergonomic flat design. In addition to the efficient use of retail space and its high performance, they are equipped with an energy-saving fan and an innovative two-level condensation removal system. These technical solutions make these refrigerated cases the most energy-efficient equipment in their range.



Vento-125



Vento-190

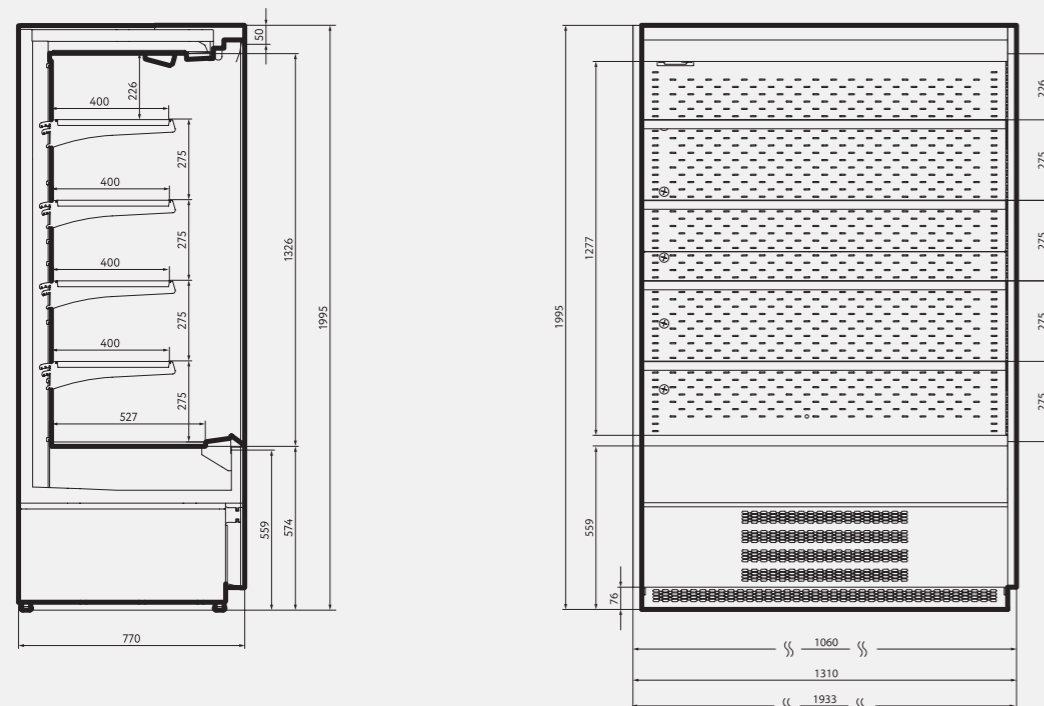

Standard Features

- ◆ **Sest** innovative evaporator, Italy
- ◆ Four rows of 400 mm deep shelves with price tags
- ◆ Coloured front panels
- ◆ Top led lighting
- ◆ Vandal-proof look-through metal side pieces with a double-glazed unit
- ◆ Energy-saving magnetic night blinds
- ◆ Wooden packaging
- ◆ **Danfoss** controller

Options

- ◆ Fruit section
- ◆ Mirror side pieces
- ◆ Plexiglass internal volume divider
- ◆ Shelf space divider
- ◆ Wire restraints
- ◆ Connection kit for aligning
- ◆ Electrical defrosting

Technical Specifications - Vento Plug-In Refrigerated Multidecks



Model	Temperature Range	Lenght without end walls	Lenght with end walls	Depth	Height	Net weight	Display area	Volume	Shelf depth	Energy consumption	Power	Refrigerant	Shelves
	°C	mm	mm	mm	mm	kg	m ²	L	mm	kW per day	kW		
Vento-125	+1 ~ +7	1178	1260	710	1946	220	2.4	860	400	17.5	1.43	R404a	4
Vento-190	+1 ~ +7	1873	1955	710	1946	350	3.8	1370	400	27.0	2.05	R404a	4

Electricals: 220V/50Hz/Single Phase

Specifications are subject to change without prior notice due to continuous product development



Plug in Multideck Chillers

The vertical open type refrigerated plug-in cabinets by Trufrost are designed to enhance product display and stimulate impulse buying in strategic areas of the store, such as in front of cash registers or promotional islands. They are ideal for packaged dairy products, beverages, packaged food, fruits & vegetables, and even certain meat & poultry items. These Multidecks have the full condensing unit system housed within the cabinet and eliminate the need for the installation of an external condenser. They offer maximum flexibility as they can be moved to different locations within the store or can be positioned away from walls as there is no requirement for pipe work to be routed outside. Finished in highly polished stainless steel, they add a touch of class to any store.

Key Features

- ◆ High efficiency and balanced refrigeration system
- ◆ Stainless steel body
- ◆ Optimised shelf depth enables more effective displayable volume
- ◆ Night curtain minimizes energy loss
- ◆ Off-cycle defrost reduces the energy consumption
- ◆ Eco friendly R404a refrigerant



PMD-1200, PMD-1800

Technical Specifications - Plug in Multidecks



Product	Model	Dimensions wxdxh (in mm)	Capacity (in Litrs)	Temperature (in °C)	Power	Refrigerant	Rated Current	Shelves
Plug In Multideck Chiller	PMD-1200	1200x670x2000	548L	+2 ~ +8	1200 W	R404a	5.5A	4
Plug In Multideck Chiller	PMD-1800	1800x670x2000	822L	+2 ~ +8	1800 W	R404a	10A	4

Electricals: 220V/50Hz/Single Phase

Specifications are subject to change without prior notice due to continuous product development

Serve Over
& Self Service Counters



Serve Over Counters - Plug-in

Trufrost presents stylish serve over counters for display of a variety of foodstuff including delicatessens, dairy products, sausages, meat and poultry that ensure maximum visibility in a pleasing manner. The front glass can be lifted for cleaning. They also come with an additional refrigerated storage underneath which can be accessed through specially provisioned small door/s at the rear.



SOC-1590, SOC 2590

Key Features

- ◆ Stylish display for dairy products, sausages, packaged meats & poultry and delicatessens
- ◆ High performance compressor
- ◆ Easy to clean, stainless steel platform on the top rear portion
- ◆ Ensures maximum visibility to the products presented
- ◆ LED lighting
- ◆ Rear storage with 1/2 doors in different models



Openable front glass



Rear storage

Self Serve Counters

These refrigerated self-service counters from Trufrost are designed to store and display deli & pastry products, sausages, packaged meats & dairy products and delicatessens. Thanks to a contemporary and functional design, they respond effectively to the multiple demands of retailers.



SSC-1350, SSC-1980

Key Features

- ◆ High performance compressor
- ◆ East to clean, stainless steel platform on the top rear portion
- ◆ Ensures maximum visibility to the products presented
- ◆ LED lighting

Stainless Steel Fish Counters

Built on a platform of stainless steel AISI 304, Trufrost fish counters are perfect for displaying fresh fish. They are designed for providing optimal chilling during display only, not as a storage vessel for continuous use. All contents should be removed and placed into refrigerated storage during out hours – the counter being clear for cleaning and sanitising prior to restocking, the next day.



SSFC-1930

Key Features

- ◆ Digital thermostat
- ◆ Adjustable feet/castor wheels
- ◆ High quality European compressor and fan
- ◆ Finned evaporator
- ◆ Thermostatic expansion valve
- ◆ Eco friendly refrigerant R404a

Technical Specifications - Serve Over & Self Serve Counters



Product	Model	Dimensions wxdxh (in mm)	Temperature range at 25 °C, 60%RH	Power	Refrigerant	Rated Current	Shelves	No. of Rear Doors
Serve Over Counters	SOC-1590	1590x918x1230	+2°C ~ +8°C	500 W	R404a	6.0A	1	1
Serve Over Counters	SOC-2590	2590x918x1230	+2°C ~ +8°C	732 W	R404a	6.0A	1	2
Self Serve Counters	SSC-1350	1350x1100x910	-2°C ~ +2°C	620 W	R404a	3.8A	-	-
Self Serve Counters	SSC-1980	1980x1100x910	-2°C ~ +2°C	676 W	R404a	4.0A	-	-
Stainless Steel Fish Counters	SSFC-1930	1930x1130x900	-5°C ~ 0°C	600W	R404a	6.0A	-	-

Electricals: 220V/50Hz/Single Phase

Specifications are subject to change without prior notice due to continuous product development

Combinable Island Freezers

With sliding glass top (left to right)

These stylish island freezers with uniquely designed curved glass lids from Trufrost come in combinable configurations although you can go for individual units as well. The exteriors are built in white pre-coated steel and the interiors in pleasing white pre-painted aluminium. They can also be converted to be used as chillers.



CIL-1650EC

CIL-2000MS

CIL-1650EC



CIL-1475MS
CIL-2000MS



CIL-1650EC

Key Features

- ◆ Elegant top curved sliding glass lid
- ◆ White pre-coated galvanized steel interior liner
- ◆ Mechanical temperature control
- ◆ 2 Tempered & low emissivity glass lids
- ◆ Lock & Key
- ◆ Ventilated free maintenance condenser
- ◆ Interior LED Lighting
- ◆ Increased 70 mm insulation resulting in energy savings
- ◆ Full Basket with dividers
- ◆ Caster wheels
- ◆ Convertible temperature range: $\leq -18^{\circ}\text{C} / 0-10^{\circ}\text{C}$

Technical Specifications - Combinable Island Freezers



Product	Model	Dimensions wxdxh (mm)	Capacity (L)	Temperature (in $^{\circ}\text{C}$)	Power	Refrigerant	Casters	Weight
Combinable Island Freezer - End Corner	CIL-1650EC	1650x757x867	600	$\leq -18 / 0-10$	395W	R290	4	85
Combinable Island Freezer - Mid Section	CIL-1475MS	1475x757x867	500	$\leq -18 / 0-10$	395W	R290	4	80
Combinable Island Freezer - Mid Section	CIL-2000MS	2000x757x867	700	$\leq -18 / 0-10$	480W	R290	6	120

Electricals: 220V/50Hz/Single Phase

Specifications are subject to change without prior notice due to continuous product development

Inviting vertical displays with glass doors





VC-1225 Premiã
VC-1250 Premiã

Visi Coolers - Premiã Series (With top mounted compressors)

These Trufrost Premiã Series plug-in type 2 glass door upright Coolers come with top mounted compressors. They provide an ultra rich and pleasing 'top to bottom' view of the displayed foodstuff – be it ice creams or any other packaged food. The cabinet interiors come with LED lights to enhance the quality of display.

Key Features

- ◆ Forced air circulation
- ◆ Adjustable shelves
- ◆ Interior LED lights
- ◆ Universal wheels, front with brake
- ◆ Double pane glass including Low E in Visi Coolers
- ◆ Triple pane glass with heated film in Visi Freezers
- ◆ Self Closing doors
- ◆ Self evaporating drip tray
- ◆ Low-maintenance condenser
- ◆ Standard ambient for Visi Coolers +35°C at 65%RH and for Visi Freezers +25°C at 60%RH
- ◆ Auto-defrost in Visi Freezers

Technical Specifications



Model	Volume (L)	Door type	Shelves	Power	Dimensions (wxdxh) mm	Temperature range	Refrigerant	No. of Compressors
VC-1225 Premiã	1225	2 Hinge	10	420W	1215x710x2050	+1°C ~ +10°C	R134a	1
VC-1250 Premiã	1250	2 Hinge	10	412W	1260x750x2092	+1°C ~ +10°C	R134a	1

Electricals: 220V/50Hz/Single Phase

Specifications are subject to change without prior notice due to continuous product development

Get your products
moving off the shelves



Showcase Coolers

Convenience stores have plenty of refrigeration and storage needs for beverage bottles, cans and tetrapaks aside of equipment for dispensing. That is where Trufrost Upright Showcases reflected in the pages ahead, come in handy.

Copper (Cu)



The key to superior refrigeration

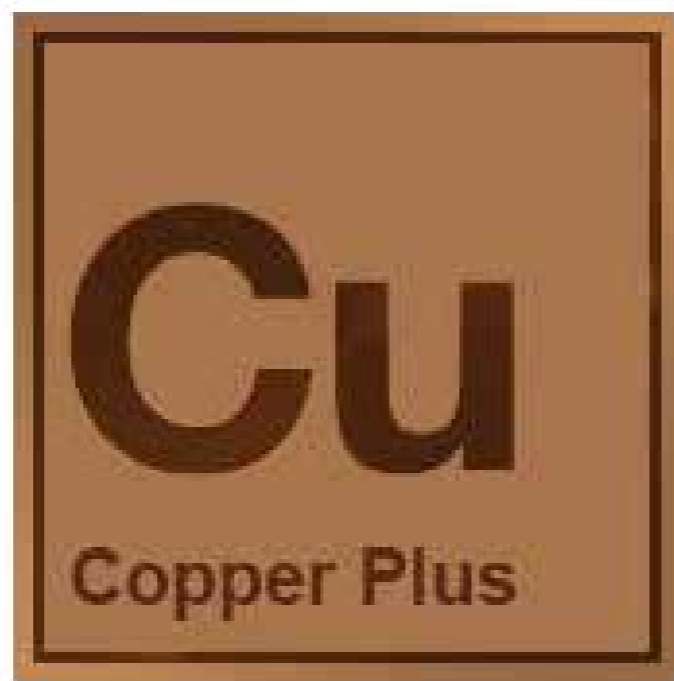

Visi Coolers - Copper Plus Series

In the world of refrigeration, Copper is the Gold Standard. The new Copper Plus series visi coolers from Trufrost are a cut above the rest. These coolers are built with copper in the compressor and forced air evaporator and condenser with copper tubes. Other features include a special Low-E glass on the doors and durable aluminium door frames tested for 3,00,000 openings/closings. A comprehensive set of superior features of the Copper Plus series is described on the next page. These innovative cooling displays are available in 410 to 1200 litre capacities and single or double door variants.



VC-451 Copper Plus



VC-551 Copper Plus



VC-651 Copper Plus



VC-1051 Copper Plus,
VC-1251 Copper Plus

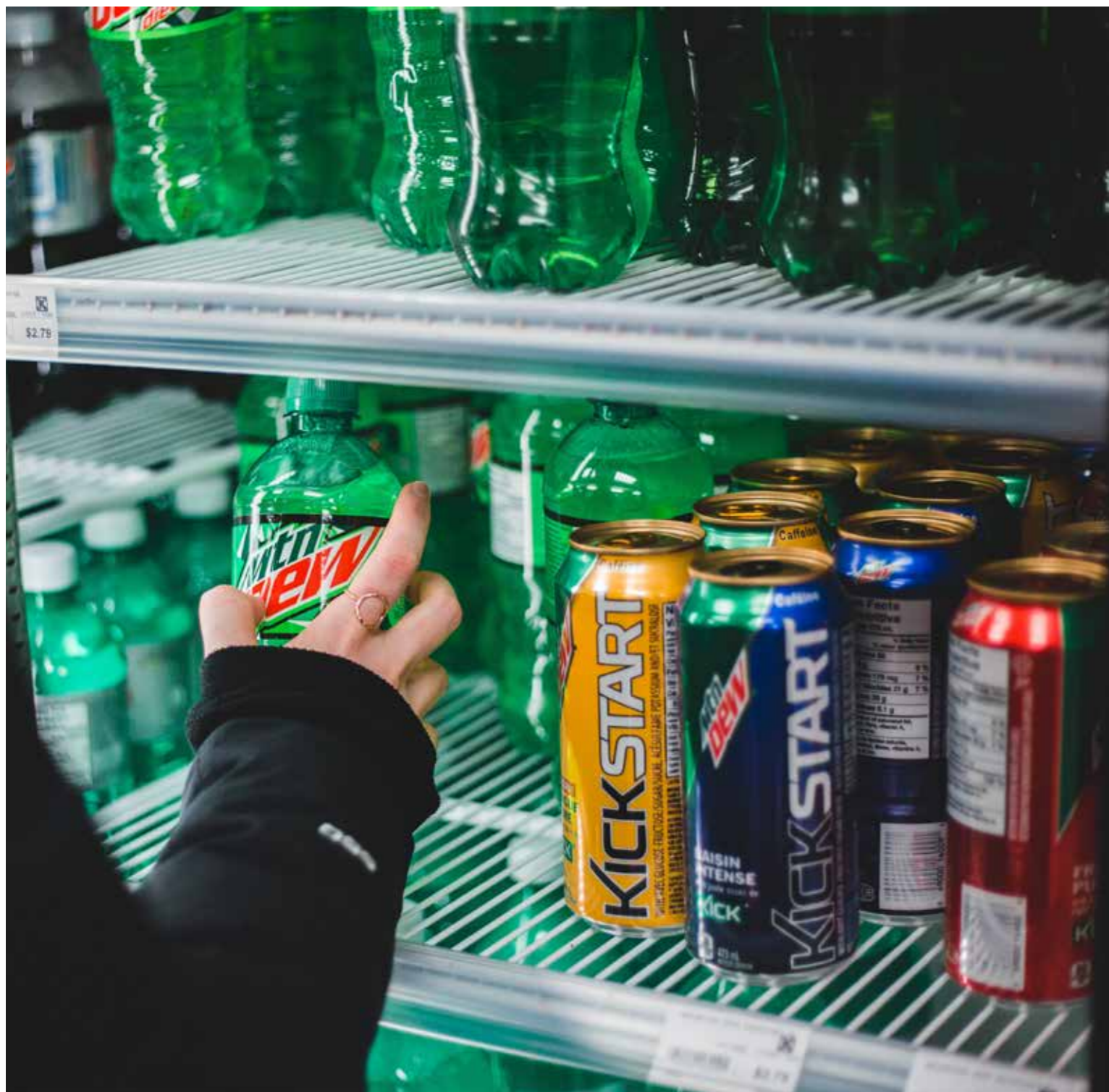

Key Features - Copper Plus Series

Here is how the new Copper Plus Series Visi Coolers from Trufrost offer unmatched features over ordinary showcases available in the market:

- ◆ Copper in the compressor and forced air evaporator and condenser with copper tubes and aluminium fins that result in:
 - ◆ Reduced power consumption and improved cooling capacity
 - ◆ 30% faster cooling
 - ◆ Improved life of compressor due to lower operating condensing pressure and temperature, even at high ambient temperature
- ◆ Low-E (Low-Emissivity) glass for supreme insulating power and consequent energy savings and reduced condensation even under high humidity
- ◆ Double tempered 4mm glass
- ◆ Designed to work in super tropical extreme conditions; tested for D Condition.
- ◆ Higher CFM indoor fan for faster and uniform cooling
- ◆ IP67 compliant LED Driver and LED Strips for better illumination
- ◆ Durable aluminium door frame tested for 3,00,000 openings/closings
- ◆ Heat exchanger in the discharge tube for evaporating drain water
- ◆ Copper ball bearing with service free sealed IP68 Motor



Technical Specifications - Visi Coolers - Copper Plus Series



Specification	Gross Volume (Litres)	Dimensions w x d x h (mm)	Temperature Range	Power (w)	Lock	Defrost	No. of Lids / Doors	No. of shelves	Interior Light	Wheels / Castors	No. of Compressors	Refrigerant
VC-451	410	583 x 715 x 1792	2 - 8°C	284	Yes	Automatic	1	4	LED light	Yes	1	R134a
VC-551	510	583 x 715 x 2053	2 - 8°C	313	Yes	Automatic	1	5	LED light	Yes	1	R134a
VC-651	610	640 x 715 x 2053	2 - 8°C	258	Yes	Automatic	1	5	Yes / 1LEDs	Yes	1	R134a
VC-1051	1050	1025 x 785 x 2182	2 - 8°C	333	Yes	Automatic	2	10	Yes / 2LEDs	Yes	1	R134a
VC-1251	1200	1152 x 785 x 2187	2 - 8°C	466	Yes	Automatic	2	10	Yes / 2LEDs	Yes	1	R134a

Electricals: 220V/50Hz/1 Phase

Specifications are subject to change without prior notice due to continuous product development





Traditional Visi Coolers

Trufrost brings to India a contemporary range of merchandising solutions that help you increase your sales by showing beverage bottles, cans, juice packs and other foodstuff at their very best. These innovative cooling displays are available in 50 to 1500 litre capacities and 1 Door/ 2 Door / 3 Door variants. They are designed to keep products at the optimum temperature and display them in a way that causes them to jump off the shelves into shopping baskets.



VC-50



VC-100 (New)



VC-220



VC-200, VC-300,
VC-400 (NEW)



VC-500



VC-600 NF (New)
VC-660 NF



VC-700 NF, VC-901,
VC-1000 NF, VC-1100 NF, VC-1200 NF



VC-999 NF



VC-1500 NF

Technical Specifications - Visi Coolers



Specification	Gross Volume (Litres)	w x d x h (inches)	Temperature Range	Power (w)	Lock	Defrost	No. of Lids / Doors	No. of shelves	Interior Light	Wheels / Castors	No. of Compressors	Refrigerant
VC-50	50	18 x 20 x 20	2 - 8°C	65	No	Yes	1	2	LED light	No	1	R134a
VC-100 (New)	100	18 x 20 x 33	2 - 8°C	65	No	Yes	1	4	LED light	No	1	R134a
VC-220	220	21 x 21 x 62	2 - 8°C	67.9	Yes	Yes	1	3	Normal light	No	1	R600a
VC-500	450	23 x 23 x 78	2 - 8°C	225	Yes	Automatic	1	5	LED light	Yes	1	R134a
VC-600NF (New)	532	25 x 28 x 81	2 - 8°C	425	Yes	Automatic	1	5	Yes / 1 LED	4	1	R134a
VC-660NF	610	28 x 27 x 82	2 - 8°C	310	Yes	Automatic	1	5	Yes / 1LEDs	4	1	R134a
VC-700NF	680	35 x 24 x 78	2 - 8°C	349	Yes	Automatic	2	8	Yes / 2LEDs	Yes	1	R134a
VC-901	900	44 x 23 x 80	2 - 8°C	430	Yes	Automatic	2	10	2 LED	4	1	R134a
VC-999 NF	1000	44 x 23 x 78	2 - 8°C	475	Yes	Automatic	2	10	2 LED	4	1	R134a
VC-1000NF	1000	44 x 27 x 82	2 - 8°C	475	Yes	Automatic	2	8	Yes / 2LEDs	Yes	1	R134a
VC-1100NF	1050	46 x 29 x 81	2 - 8°C	550	Yes	Automatic	2	10	Yes / 2LEDs	4	1	R134a
VC-1200NF	1200	46 x 31 x 86	2 - 8°C	615	Yes	Automatic	2	10	Yes / 2LEDs	4	1	R134a
VC-1500NF	1495	71 x 27 x 82	2 - 8°C	687	Yes	Automatic	3	15	Yes / 5LEDs	Yes	1	R134a

Electricals: 220V/50Hz/1 Phase Specifications are subject to change without prior notice due to continuous product development
Working condition for open chillers/glass door freezer is class 3 (Room Temp. 25°C and 60%RH)

Specification	Gross Volume (Litres)	w x d x h (inches)	Temperature Range	Power (w)	Lock	Fan	No. of Lids / Doors	No. of shelves	Interior Light	Wheels / Castors	No. of Compressors	Refrigerant
VC-200	180	17 x 20 x 55	2 - 8°C	170	Yes	Yes	1	3	LED light	No	1	R600a
VC-300	280	21 x 20 x 61	2 - 8°C	200	Yes	Yes	1	3	LED light	Yes	1	R600a
VC-400 (New)	380	23 x 20 x 70	2 - 8°C	240	Yes	Yes	1	4	LED light	Yes	1	R600a

Electricals: 220V/50Hz/1 Phase Specifications are subject to change without prior notice due to continuous product development
Working condition for open chillers/glass door freezer is class 3 (Room Temp. 25°C and 60%RH)





Visi Coolers - New Series

Trufrost has just rolled out models in a new series of showcase coolers in 1 Door/ 2 Door / 3 Door variants. They are designed to keep products at the optimum temperature and display them in a way that causes them to jump off the shelves into shopping baskets.



VC-333



VC-444



VC-777, VC-1111



VC-1555



Technical Specifications - Visi Coolers



Specification	Gross Volume (Litres)	Dimensions w x d x h (mm)	Temperature Range	Power (w)	Lock	Defrost	No. of Lids / Doors	No. of shelves	Interior Light	Wheels / Castors	No. of Compressors	Refrigerant
VC-333	290	530*560*1850	2 - 8°C	160	Yes	Automatic	1	4	LED light	Yes	1	R134a
VC-444	410	580*610*1900	2 - 8°C	210	Yes	Automatic	1	4	LED light	Yes	1	R134a
VC-777	710	1050*610*2000	2 - 8°C	350	Yes	Automatic	2	8	Yes / 2LEDs	Yes	1	R134a
VC-1111	1050	1215*700*2000	2 - 8°C	350	Yes	Automatic	2	8	Yes / 2LEDs	Yes	1	R134a
VC-1555	1495	1830*700*2000	2 - 8°C	460	Yes	Automatic	3	12	Yes / 2LEDs	Yes	1	R134a

Electricals: 220V/50Hz/1 Phase Specifications are subject to change without prior notice due to continuous product development
Working condition for open chillers/glass door freezer is class 3 (Room Temp. 25°C and 60%RH)

3 Door Visi Cooler/Freezer Combo

This unique 3 door product has a multi-function utility with two separate compartments for cooling (750 litres) and freezing (350 litres) and are ideal for displaying beverages, dairy products as well as ice creams and frozen products. It comes with 2 compressors and 2 controllers.

CHILLER & FREEZER

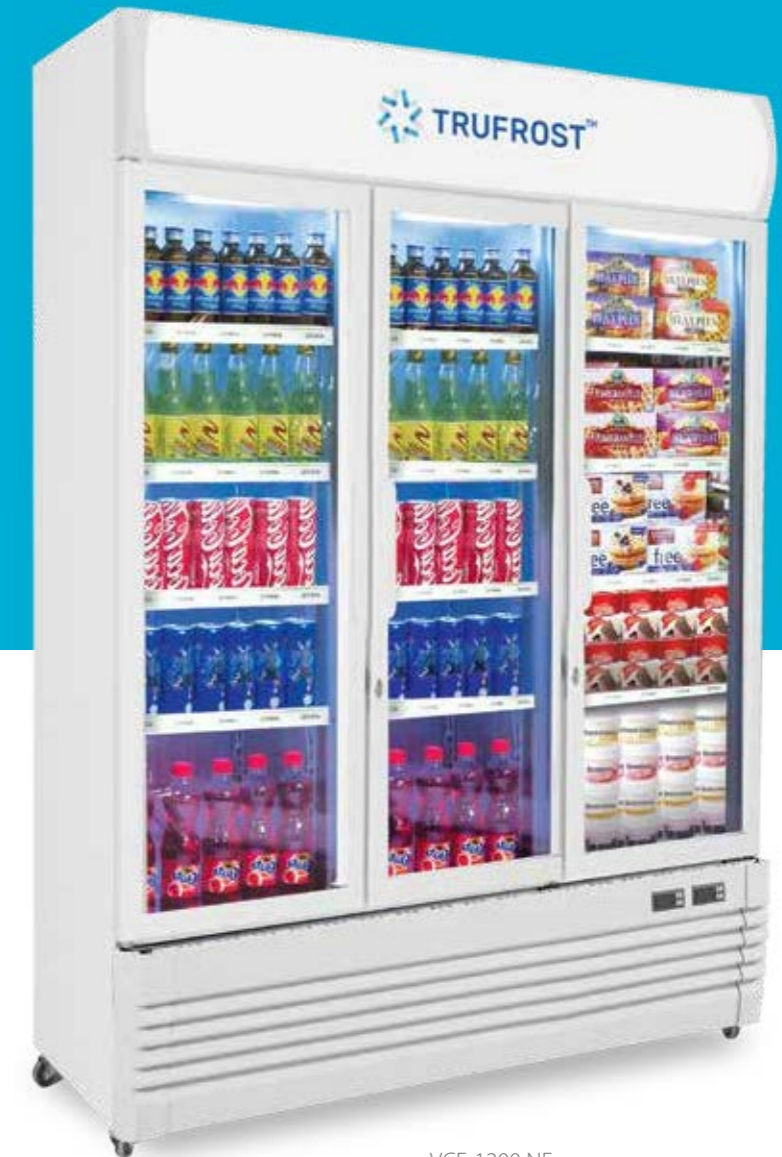

VCF-1200 NF

Key Features

- ◆ Forced air circulation
- ◆ Adjustable shelves
- ◆ Interior LED lights
- ◆ With lock & key
- ◆ Self closing door
- ◆ Self evaporating drip tray

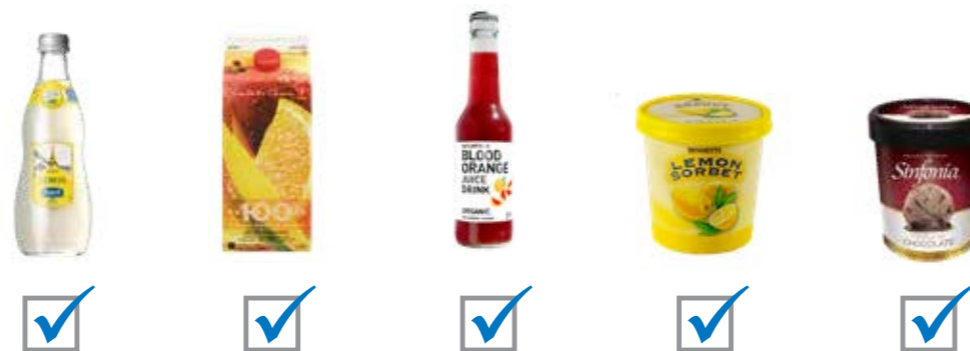

Technical Specifications



Specification	Gross Volume (Litres)	w x d x h (inches)	Temperature Range	Power (w)	Lock	Defrost	No. of Lids / Doors	No. of shelves	Interior Light	Wheels / Castors	No. of Compressors	Refrigerant
VCF-1200NF	1100	52 x 27 x 82	2-8°C / ≤-18°C	970	Yes	Automatic	3	15	Yes / 3LEDs	Yes	2	R404a

Electricals: 220V/50Hz/1 Phase Specifications are subject to change without prior notice due to continuous product development



Visi Freezers

Trufrost upright visi freezers are known for their reliability. VF 100 comes in an elegant champagne colour and the rest in an elegant white coloured body and provide a pleasing view of the displayed foodstuff – be it ice creams or any other packaged frozen food. You can choose between three models that are available in 100, 300, 400 and 1000 litre capacities and are fitted with LED lights to enhance the quality of display. VF 100, 300, 400 & 1000 come a ventilated cooling system with automatic defrost.



VF-375NF
Visi Freezer



VF-400
Visi Freezer



VF-1000
2 Door Visi Freezer
New upgraded model with
2 compressors



Technical Specifications of Visi Coolers & Visi Freezers



Specification	Gross Volume (Litres)	Dimensions w x d x h (mm)	Temperature Range	Power (w)	Lock	Defrost	No. of Lids / Doors	No. of Shelves	Interior Light	Wheels / Castors	No. of Compressors	Refrigerant
VF-375NF	375	23 x 24 x 80	-18°C ~ -22°C	760	Yes	Automatic	1	4	Yes / 1LEDs	Yes	1	R404a
VF-400	400	26 x 28 x 78	-18°C ~ -22°C	570	Yes	Automatic	1	5	2 LEDs	Yes	1	R404a
VF-1000NF	950	48 x 28 x 78	-18°C ~ -22°C	1250	Yes	Automatic	2	10	2 LEDs	Yes	2	R404a

Electricals: 220V/50Hz/1 Phase Specifications are subject to change without prior notice due to continuous product development

The art & science of cooling





Glass Top Freezers - Deluxe series

These Trufrost Flat Glass Freezers add a new dimension to the routine glass tops available in the market. They come with LED light to enhance the product display - feature that is a retailer's delight. GT 440 Dlx and GT 650 Dlx come with 4 and 6 fully loaded baskets respectively (2 of which are QDI baskets), for easy access & convenient segregation of the displayed items. They come with an extra thick 75 mm insulation and an elegant aluminium door frame that contrasts well with the white freezer body.



LED Light



Full basket



Prepainted aluminum plate

Aluminium alloy door frame



Double row Casters

Models available

- 1 GT-440 Dlx (with 4 baskets)
- 1 GT-650 Dlx (with 6 baskets)



Temperature display

Key Features

- ◆ New style flat sliding glass lid
- ◆ Fully Automatic operation
- ◆ 75 mm thickness insulation
- ◆ Exterior white finish
- ◆ Aluminum door frame
- ◆ Adjustable thermostat
- ◆ Main power indicator
- ◆ Defrost water drain hole
- ◆ Full basket as standard
- ◆ Interior LED light as standard
- ◆ Four caster wheels
- ◆ Environmentally friendly



Flat Glass Top Freezers

Trufrost Flat Glass Freezers are a retailer's delight and come with fully loaded baskets for easy access & convenient segregation of frozen food.



- Models available**
- GT-100 (with 1 basket)



- Models available**
- GT-255 (with 1 basket)
 - GT-355 (with 4 baskets)
 - GT-455 (with 4 baskets)
 - GT-555 (with 4 baskets)



Curved Glass Top Freezers

Trufrost Curved Glass Freezers are a retailer's delight. GTC 330 and 400 come with 3 baskets and GTC 625 has 9 baskets with 18 separators for easy access & convenient segregation of frozen food.

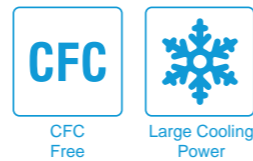

GTC 330 (with 3 baskets)
GTC 450 (with 5 baskets)



GTC 625 (with 9 baskets with 18 Separators)

Technical Specifications



Specification	Glass Top Freezers - Deluxe series			Flat Glass Top Freezers				Curved Glass Top Freezers		
	GT-440 DLX	GT-650 DLX	GT-100	GT-255	GT-355	GT-455	GT-555	GTC-330	GTC-450	GTC-625
Gross Volume (Litres)	400	600	100	230	330	430	530	330	430	610
w*d*h (inches)	50x27x34	71x27x34	23x21x33	32x27x31	44x27x31	55x27x31	66x27x31	41x26x35	50x27x34	71x27x34
Temperature Range	≤-18°C	≤-18°C	≤-20°C	+5°C ~ -27°C	+5°C ~ -27°C	+5°C ~ -27°C	+5°C ~ -27°C	≤-20°C	≤-20°C	≤-20°C
Power (W)	210	252	133	290	320	345	395	215	200	240
Refrigerent	R290	R290	R134a	R134a	R290	R290	R290	R134a	R290	R290
Lock	Yes	Yes	Yes	Yes	Yes	Yes	Yes	Yes	Yes	Yes
Defrost	Manual	Manual	Manual	Manual	Manual	Manual	Manual	Manual	Manual	Manual
No. of Lids / Doors	2	2	2	2	2	2	2	2	2	2
No. of Baskets	4 (2 standard + 2 QDI)	6 (4 standard + 2 QDI)	1	1	4	5	5	3	5	9
Wheels / Castors	4	6	Yes	Yes	Yes	Yes	Yes	Yes	Yes	Yes

Electricals: 220V/50Hz/1 Phase

Specifications are subject to change without prior notice due to continuous product development

No Frost Convertible Chest Freezers / Chillers

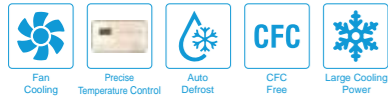

This is a pioneering product from Trufrost. Ideal for homes, medicine shops, high traffic stores and busy restaurants, this unmatched feature makes manual defrosting a thing of the past. It also features precise temperature control, a digital temperature indicator and a full set of baskets for segregated, easy-to-access loading while the multi-dimensional air flow ensures uniform cooling inside the cabinet.



Key Features (NF-150)

- ◆ Self-adaptive frost system
- ◆ Precise temperature control
- ◆ Multi-dimensional wind circulation
- ◆ Embedded handle
- ◆ Digital temperature indicator
- ◆ Two baskets



Single Lid Models

- ◆ CF-110
- ◆ CF-220 Dlx.
- ◆ CF-222
- ◆ CF-300 Dlx.
- ◆ CF-333

2-in-1 Convertible Chest Freezers / Chillers



Trufrost 2-in-1 hard top chest freezers conveniently double up as chillers at the turn of a knob and are available in a wide variety of sizes ranging from 100 to 820 litres to suit every conceivable need. You can also choose between single, double and three lid variants.



Double Lid Models

- ◆ CF-333 2D
- ◆ CF-400 2D (not convertible into chiller)
- ◆ CF-444 2D
- ◆ CF-500 2D
- ◆ CF 500 2D (New)
- ◆ CF 550 2D (New)
- ◆ CF 550 2D Dlx.
- ◆ CF 555 2D
- ◆ CF 700 2D
- ◆ CF 700 2D (New)
- ◆ CF 800 2D



Three Lid Models

- ◆ CF-720 3D

Technical Specifications



Model	Gross Volume (Litres)	Dimensions w*d*h (mm)	Temperature Range	Power (W)	Refrigerent	Lock	Defrost	No. of Lids / Doors	No. of Baskets	Wheels / Castors
NF-150	145	714*550*903	≤-20°C	97	R 290	Yes	No Frost	1	2	Yes

Electricals: 220V/50Hz/1 Phase Specifications are subject to change without prior notice due to continuous product development



Technical Specifications



Model	Gross Volume (L)	w*d*h (mm)	Temperature Range	Power (W)	Refrigerent	Lock	Defrost	No. of Lids / Doors	No. of Baskets	Wheels / Castors
CF-110	100	560*595*790	+2°C -20°C	110	R600a	Yes	Manual	1	1	Yes
CF-220 Dlx	200	860*540*835	+2°C -20°C	103	R 600a	Yes	Manual	1	1	Yes
CF-222	220	815*720*845	-18°C ~ -24°C (F) +0°C ~ +10°C (C)	154	R 600a	Yes	Manual	1	1	Yes
CF-300 Dlx	276	1080*600*835	+2°C -20°C	115	R 134a	Yes	Manual	1	1	Yes
CF-333	330	1115*720*845	-18°C ~ -24°C (F) +0°C ~ +10°C (C)	295	R 290	Yes	Manual	1	1	Yes
CF-333 -2D	330	1115*720*845	-18°C ~ -24°C (F) +0°C ~ +10°C (C)	295	R 290	Yes	Manual	2	1	Yes
CF-400-2D	400	1304*670*830	≤-20°C	270	R 134a	Yes	Manual	2	2	Yes
CF-444-2D	440	1395*720*845	+2°C -20°C	295	R 290	Yes	Manual	2	2	Yes
CF-500-2D	470	1523*725*842	+2°C -20°C	253	R 134a	Yes	Manual	2	2	Yes
CF-550-2D Dlx	550	1683*670*880	+2°C -20°C	300	R 290	Yes	Manual	2	1	Yes (6)
CF-555-2D	550	1685*720*845	-18°C ~ -24°C (F) +0°C ~ +10°C (C)	395	R 290	Yes	Manual	2	2	Yes
CF-700-2D	680	1843*725*842	+2°C -20°C	305	R 134a	Yes	Manual	2	2	Yes
CF-700-2D (New)	680	1810*755*840	+2°C -20°C	300	R 600a	Yes	Manual	2	2	Yes
CF-800-2D	800	2000*740*850	+2°C -20°C	330	R 290	Yes	Manual	2	2	Yes
CF-720-3D	700	1810*755*840	+2°C -20°C	320	R 600a	Yes	Manual	3	2	Yes

Electricals: 220V/50Hz/1 Phase Specifications are subject to change without prior notice due to continuous product development

Traditional Island Freezers

Trufrost Island Freezers are a retailer's delight and come with fully loaded baskets for easy access & convenient segregation of frozen food. IL 450 and IL 660 (New) come with 4 baskets each.



Models available

- ◆ IL-450 (with 4 baskets)
- ◆ IL-660 (New) (with 4 baskets)

Dual Temperature Freezers / Chillers

Trufrost dual temp freezers/chillers have two segregated storage compartments – ideal for storing ice-creams & frozen foods in one and dairy products or beverages in the other.



Models available

- ◆ DT-300
- ◆ DT-444

Milk / Bottle Chiller

Trufrost Milk Chillers come with a food-grade stainless steel inner compartment that allows for optimum temperature management of pre-refrigerated milk. The product is suitable for chilled milk to be poured directly into the tank. It is also suitable for storing & chilling bottled beverages and other food-stuff.



Models available

- ◆ BC-400-2D-SS

Technical Specifications

Specification	Island Freezers		Dual Temp Freezers		Milk Chiller
	IL-450	IL-660 (New)	DT-300	DT-444	BC-400-2D-SS
Gross Volume (Litres)	450	660	162F/120C*	200F/225C*	360
w*d*h (inches)	70x29x33	74x32x34	46x24x33	55x28x34	50x26x33
Temperature Range	≤-18°C	≤-18°C	+2°C -20°C	-18°C ~ -24°C (F) +0°C ~ +10°C (C)	2~10°C
Power (w)	355	380	195	268	233
Refrigerant	R290	R134a	R134a	R290	R134a
Lock	Yes	Yes	Yes	Yes	Yes
Defrost	Manual	Manual	Manual	Manual	Manual
No. of Lids / Doors	2	2	2	2	2
No. of Baskets	4	4	1	1	
Wheels / Castors	Yes	Yes	Yes	Yes	Yes

Electricals: 220V/50Hz/1 Phase

Specifications are subject to change without prior notice due to continuous product development



Compressor Minibars

Trufrost Mini Fridges are ideal for use as minibars in guest rooms of hotels and clubs and also in homes. They are built with special low noise compressors and come with interior light and a lock and are available in a neutral, pleasing white colour. Model MF-55 has a small freezing chamber.



MF 55

Technical Specifications



Model	Dimension W x D x H (mm)	Net Weight (kgs)	Refrigerator Volume	Power Rated (W)	Temp. °C	Cooling	Refrigerant
MF-55	445X475X510	16	47	80W	0-7	Compressor	R600a

Electricals: 220V/50Hz/1 Phase

Specifications are subject to change without prior notice due to continuous product development

Cooling
without distraction



The science of
preserving food anywhere



For an actual picture of the product, please see on the reverse of this page.

Freezer on Wheels

The Trufrost FOW-110 is a deep freezer with a difference. It can be virtually taken anywhere and comes with an efficient glycol based eutectic system that allows for the freezer to perform well without electricity for several hours once it has been sufficiently charged. The product is ideal for sales of ice creams and other frozen foods when mounted on a cycle rickshaw or a push cart (not supplied with the freezer).



FOW-110

Technical Specifications

Model	Capacity in Litre	Capacity in CFT	Capacity in Gallons	Temperature Range	Power (W)	Current (Amps)	Dimensions WxDxH (mm)	Doors (on top)	Refrigerant	Stabilizer Required
FOW-110	110	3.9	20	-18 to 30°C	315W	1.64	975x640x750	1 in SS	R 134a	1KW

Electricals: 220V/50Hz/1 Phase Specifications are subject to change without prior notice due to continuous product development



The art & science of **food preservation**



Team Trufrost has an expertise in design, supply, installation and after-service for your coldroom needs. Having worked extensively in the cold chain industry for over 3 decades, we've devoted ourselves to creating products and solutions that are extremely dependable. Our team has done extensive work with leading brands like Accor, Hilton, Marriott, Taj Hotels, Subway, Sanofi, Johnson & Johnson, Ranbaxy, Dinshaw's, Radisson, Westin, Park Plaza, Haldiram, Ramada, Amul, ITC, Oberoi, Shantha Biotechnics, Radha Regent, Cisco, Nilgiris and many more names.



The Coldroom Experts

Team Trufrost has an expertise in design, supply, installation and after-service for your coldroom needs. Having worked extensively in the cold chain industry for over 3 decades, we've devoted ourselves to creating products and solutions that are extremely dependable. Our team has done extensive work with leading brands like Google, Bahrain International Airport, Hyatt, Hilton, Marriott, Taj Hotels, Leela, Sanofi, Johnson & Johnson, Ranbaxy, Dinshaw's, Radisson, Westin, IBIS, Haldiram, Curefit, Ramada, ITC, Oberoi, Cisco and many more names.



Walk-in Coldrooms

We specialize in preservation & storage of products ranging from hospitality, frozen foods, fresh produce, dairy products, beverages, to medicines & vaccinations and more. Be it small walk-in coolers & freezers, or large refrigerated warehouses, Trufrost Coldrooms are easy to install, use, and maintain, keeping you up and running from the very start.



Key Features - Trufrost Coldrooms

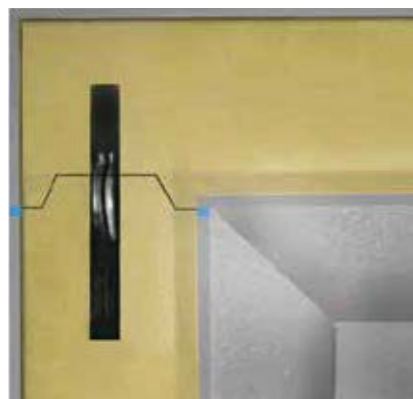

Cam Locking & Gaskets

Our camlocks ensure strong, perfect alignment of all joints. Food-grade PVC gaskets make them neat & leak-proof and are a superior replacement of silicon sealants.



Rounded Corners

Trufrost gives you the option of rounded corner and T-joint on wall to wall, wall to ceiling (only imported) and wall to floor sections that enables easy cleaning of corners and utmost hygiene in your cold room.



Inside & Outside Ramp

Site conditions are often not perfect but you may still need to move in and out of cold rooms frequently. Trufrost custom designed ramps ensure that you cart out your foodstuff on trolleys, unhindered.

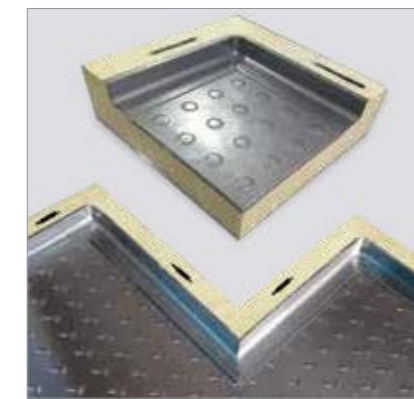

Custom Built Panels

Trufrost PUF Panels can be made to suit your layout design and site conditions. Our sizes are flexible and use L, T and + shape panels to ensure the cold rooms are structurally strong, rivet-free and hygienic.



Sliding Doors

Perfect solution for tight alleys but a wider opening requirement. Trufrost offers heavy duty sliding doors with highly durable, European accessories.



Shelving System

Trufrost offers shelving for cold rooms with option of SS304 or SS201. We offer you optimal storage system to maximise space utilisation in a coldroom to suit different budgets.



Control Panel (with I.O.T.)

Our control panels are designed to maximise the performance of all types of refrigeration systems. Optional features of remote monitoring and BMS compatibility are available.



LED lighting (optional)

Energy saving LED lighting options designed for damp, wet, walk-in coolers or freezers applications are available from Trufrost. We also offer IP65 lighting.



Panel Finishes

Trufrost offers a wide choice of panel finishes to suit any application. We can help you choose the right sheet thickness for each finish depending upon your need.

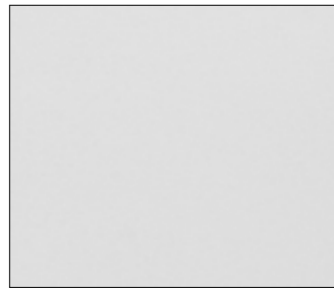

Pre-Painted White Sheet
0.4/0.5/0.6/0.8/1.0/1.2 mm



PVC Finish.
0.6/0.8/1.0/1.2 mm



Galvanized Sheet.
0.5/0.6/0.8/1.0/1.2 mm



Stucco Aluminum Sheet.
0.5/0.6/0.8/1.0/1.2 mm



S.S. Sheet (#304)
0.5/0.6/0.8/1.0/1.2 mm

Physical Property of PUF & PIR Panels

PUF Thickness (mm)	Recommended Temp. Degree @ 32°C Ambient Temp.	Weight						Thermal Conductivity 'K' Value W/mK	Thermal Transmittance 'U' Value W/m²K	Thermal Resistance 'R' Value m²K/W	Thermal Transmittance 'U' Value K.Cal/m²K	Thermal Resistance 'R' Value m²K/K.Cal
		Wall & Ceiling		Floor Panel								
		Kg/Sq.ft	Kg./Sq.mtr	Floor Bare Slab		Alu. Checkered Floor						
Kg/Sq.ft	Kg./Sq.mtr			Kg/Sq.ft	Kg./Sq.mtr							
60	+20 to +2	1.5	16	0.25	3	2.5	27	0.022	0.3521	2.84	0.3018	3.31
80	+2 to -8	1.6	17	0.35	4	2.6	28	0.022	0.2679	3.73	0.2296	4.36
100	-8 to -18	1.7	18	0.425	5	2.7	29	0.022	0.2163	4.62	0.1854	5.39
125	-18 to -27	1.85	20	0.525	6	2.85	31	0.022	0.1721	5.81	0.1475	6.78
150	-27 to -50	2	22	0.65	7	3	32	0.022	0.1459	6.85	0.1251	7.99

Insulation Property of PUF & PIR Panels

Panel Thickness (mm)	Thermal Flux (Heat loss per m2 wall area) at different ΔT									
	W/m³					K.Cal/m³				
	60	80	100	125	150	60	80	100	125	150
Temp. Difference °C										
1	0.3521	0.2679	0.2163	0.1721	0.1459	0.3018	0.2296	0.1854	0.1475	0.1251
10	3.5205	2.6797	2.1631	1.7556	1.4596	3.0174	2.2968	1.854	1.5047	1.251
15	5.2808	4.0196	3.2446	2.6335	2.1894	4.5262	3.4452	2.781	2.2572	1.8766
20	7.0411	5.3595	4.3262	3.5113	2.9192	6.0349	4.5936	3.708	3.0095	2.5021
25	8.8014	6.6993	5.4077	4.3891	3.6491	7.5437	5.7419	4.635	3.7619	3.1276
30	10.5617	8.0391	6.4893	5.267	4.3789	9.0524	6.8903	5.562	4.5143	3.7531
35	12.3219	9.379	7.5708	6.1447	5.1087	10.5611	8.0387	6.489	5.2667	4.3786
40	14.0822	10.7189	8.6524	7.0226	5.8384	12.0699	9.1871	7.4159	6.0191	5.0041
45	15.8424	12.0587	9.734	7.9004	6.5682	13.5786	10.3356	8.343	6.7714	5.6296
50	17.6028	13.3986	10.8155	8.7782	7.298	15.0873	11.484	9.2699	7.5238	6.2551
55	19.3631	14.7385	11.8971	9.6561	8.0278	16.5961	12.6324	10.197	8.2762	6.8806
60	21.1239	16.0784	12.9786	10.5339	8.7576	18.1053	13.7808	11.1239	9.0286	7.5062
65	22.8836	17.4182	14.0602	11.4117	9.4874	19.6135	14.9292	12.051	9.781	8.1317
70	24.6439	18.4382	15.1417	12.2896	10.2172	21.1223	15.8034	12.9779	10.5334	8.7572
80	28.1644	21.4377	17.3048	14.0452	11.6769	24.1397	18.3743	14.832	12.0382	10.0082

Wall Drain System

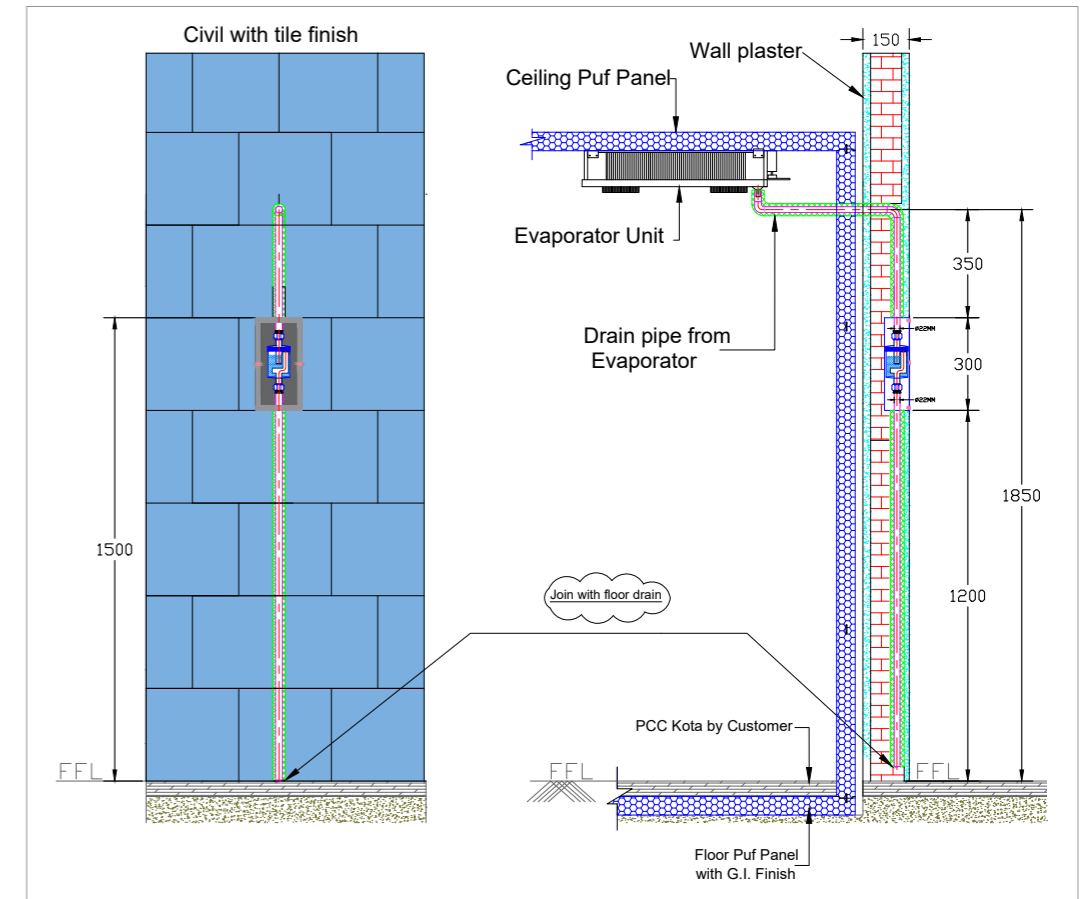
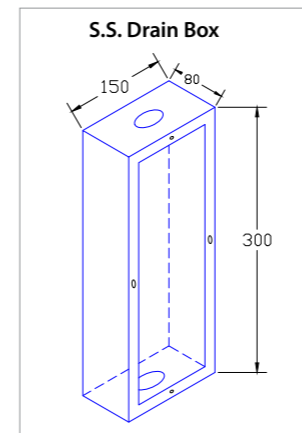
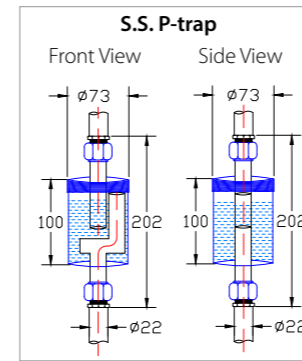

Floor Finishes

Although often overlooked, coldroom floors play a vital part in ensuring hassle free operation and maintaining a consistent temperature. Trufrost offers a wide choice of floor types to suit any application.



Contemporary ALTRO Safety Floor finish for wet application for premium kitchens



Kota Stone / Tiled Floor finish for wet & rough application for all types of kitchens and processing halls.

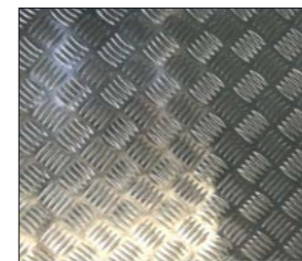

Aluminium Chequered 1.2 to 3.0 mm for Pharma, Ice Cream and any water free applications



Galvanized Sheet. 0.5/0.6/0.8/1.0/1.2/1.5 mm for dry applications



S.S. Dimple plates 0.8 to 2.0 mm for all dry type special applications

Flush door with accessories

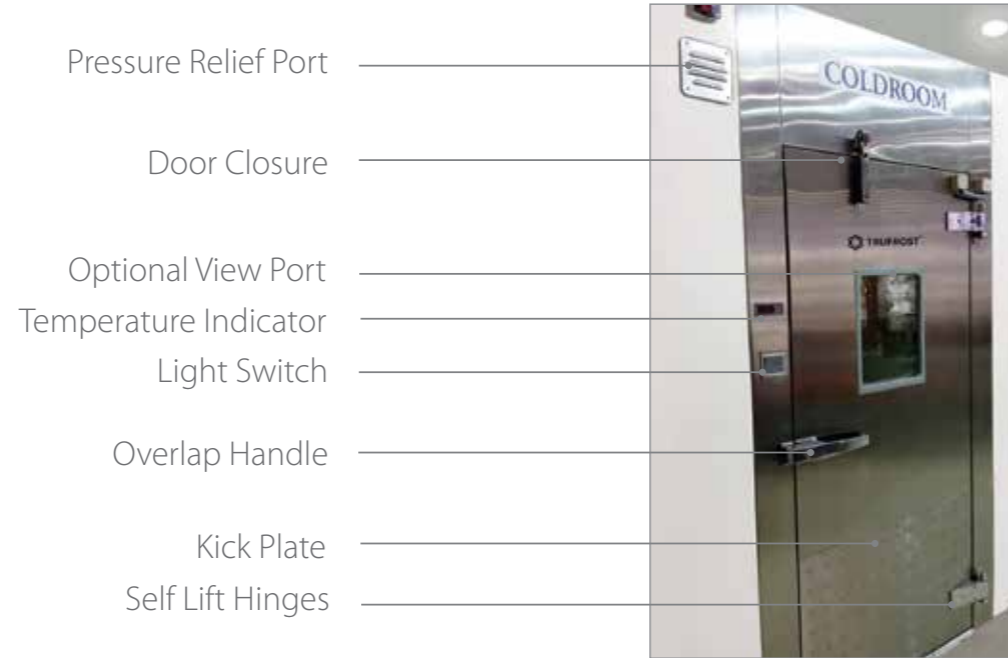

Variety of doors & accessories options

- ◆ Hinge Doors
- ◆ Sliding Doors
- ◆ High Speed Roll-up Doors
- ◆ Flip-flap Doors
- ◆ Sectional Doors
- ◆ Service Doors
- ◆ Dock Seal
- ◆ Dock Levelers

Evaporators

Trufrost is known for high quality evaporator units suited to site requirements, using Sim or low profile, with low energy fans, where available.

Slim

This is a long, slim, compact evaporator for maximising head and storage height below the evaporator and is suitable for the majority of standard commercial coldroom applications.



Cube

These low profile evaporators are ideal for small size cold and freezer rooms. You can use full size shelving to maximise your storage space.



Taper

These are for medium sized cold rooms for all applications with high and low humidity.



Boxer & Hyper

Large commercial, industrial and specialist application type evaporators with high air velocity for greater air throw distances with medium to low temperature and low to high humidity.





Energy-efficient Refrigeration Units

Presenting Trufrost Refrigeration Systems with temperatures ranging from -86°C to +22°C. These world-class Condensing units and Evaporator units are the perfect complement to your Coldroom Panels.

Salient Features :

- ◆ Rack systems with option of inverter compressor
- ◆ Original factory manufactured energy-efficient condensing unit for accurate performance
- ◆ Designed for tropicised conditions (Class T)
- ◆ Stainless steel or pre-painted aluminium evaporators
- ◆ Slim & Taper profile evaporators for space optimisation
- ◆ Silicon heater in drain help in quick installation and easy replacement
- ◆ Option of hermetic scroll & semi-hermetic compressors
- ◆ Option of remote monitoring for BMS compatible HACCP controller



Technical Specifications - Refrigeration System

Model No. Cond. Unit	Model No. Evapo. Unit	Refrigeration Capacity BTU/Hr.	Max. Room Volume (CFT)	Max. Room Area with 8'Ht. (Sq.Ft.)	Temp. Range (C)	Max. Loading (Kgs./Day)	Loading Temp. (C)	Ambient (C)	Power Supply (V/Ph/Hz)	Power* Consumption (Kw)	Defrosting (Type)	Approx. weight (Kgs.)
TH-AH-008-21	Slimmer-S2-08-AL	8000	525	65	2 to 6	300	30	38 to 43	230/1/50	1.6	Off-cycle	70
TH-AH-012-21	Slimmer-S3-12-AL	12000	1000	125	2 to 6	580	30	38 to 43	230/1/50	2	Off-cycle	90
TH-AH-015-21	Slimmer-S4-16-AL	15000	1400	175	2 to 6	810	30	38 to 43	230/1/50	2.5	Off-cycle	110
TH-AH-019-23	Slimmer-S5-20-AL	19000	1900	240	2 to 6	1115	30	38 to 43	400/3/50	3	Off-cycle	148
TH-AH-021-23	Boxer-K34-21-AL	21000	2200	275	2 to 6	1278	30	38 to 43	400/3/50	3.4	Off-cycle	150
TH-AH-036-23	Boxer-K44-36-AL	36000	4000	500	2 to 6	2320	30	38 to 43	400/3/50	5.3	Off-cycle	170
TH-AH-041-23	Boxer-K44-42-ALX	41000	4700	580	2 to 6	2700	30	38 to 43	400/3/50	5.8	Off-cycle	180
TH-AS-060-23	Hyper-H44-60-PPX	60000	7000	875	2 to 6	4065	30	38 to 43	400/3/50	7.6	Off-cycle	220
TH-AS-080-43	Hyper-H45-80-PPX	80000	9000	1125	2 to 6	5225	30	38 to 43	400/3/50	9	Off-cycle	250
TL-AH-005-41	Cuber-S2-05E-AL	5000	240	30	-16 to -18	85	-10	38 to 43	230/1/50	1.5	Electric	78
TL-ASH-007-43	Boxer-K23-07E-ALX	7000	800	100	-18 to -22	280	-10	38 to 43	400/3/50	2	Electric	85
TL-ASH-009-43	Boxer-K24-09E-ALX	9000	1200	150	-18 to -22	425	-10	38 to 43	400/3/50	2.6	Electric	88
TL-ASH-012-43	Boxer-K34-12E-AL	12000	1500	188	-18 to -22	525	-10	38 to 43	400/3/50	3.5	Electric	125
TL-ASH-016-43	Boxer-K43-17E-AL	15500	2000	250	-18 to -22	700	-10	38 to 43	400/3/50	4.3	Electric	150
TL-ASH-020-43	Boxer-K44-20E-ALX	20000	3000	375	-18 to -22	1050	-10	38 to 43	400/3/50	6	Electric	190

Basis of Design : (A) Loading will be 50 Kgs / Sq.ft. / day for Chiller room and 30 Kgs / Sq.ft. / day for Freezer room. (B) Door Openings : 3 to 5 / Hr. (C) Refrigerant : R22 / R407C / R404a / R134a for TH range and R-404a for TL range of equipment. (D) Supply Voltage : 200V - 240V for single phase while 400V - 440V for three-phase supply, otherwise use voltage stabiliser. (E) TH range offered for +22°C to +1°C is with Hermetic Danfoss / Emerson / Techemseh compressor, while TL range is offered for -1°C to -86°C with Hermetic Emerson for small capacities and Semi-Hermetic Bitzer / Dorin / Emerson compressors for higher capacities.

Trufrost reserves the right to change the specifications without prior notice

Condensing Units

Trufrost offers a variety of condensing units. Their selection is based on cold room size and usage.

Air Cooled Semi-hermetic: these are generally for small to industrial applications, excessive pipe run or vertical lift distances and speciality blast chilling and freezing applications. They are highly efficient and perform tirelessly.

Water Cooled Semi-hermetic: these are similar to above and use water from cooling tower or chiller to further improve the efficiency.

Reciprocating Hermetic: for standard cold rooms with split type remote unit application. These are economical and easy to install.

Hermetic Scroll: for medium to larger rooms, longer horizontal pipe runs and speciality applications such as blast chilling and medium temperature application.



Air Cooled



Water Cooled



Hermetic Recip/Scroll





Ecostar Inverter refrigeration system

The new Bitzer Ecostar from Germany comes with inbuilt variable frequency inverter that can reduce your operating cost by up to 30%. This can operate between 25 to 87 Hz frequency and it is 'plug & play'. These are compact, top discharge units that can be kept next to wall, hence space saving. A single system can run upto 6 cold rooms or 4 freezer rooms and is ideal for hotels and warehousing.



Ecolite With capacity control

The Bitzer Ecolite air cooled CDUs from Germany are highly flexible, sustainable and easy to install. These plug & play machines come with smart Bitzer controller allowing simple implementation in the cooling system and constant monitoring of operating parameters and settings. A single system can run upto 6 cold rooms or 4 freezer rooms and is ideal for hotels and banqueting applications.

Bitzer Rack Systems

The Bitzer Multipac & Hyperpac, multi compressor rack system comes with the proven series of new Bitzer Ecoline Semi Hermetic compressors & Screw compressors. They are surprisingly compact, yet solidly built and are known for enhanced performance and reduced pipe work.

Varipac: Addition of an inverter in the rack enhances its efficiency and increases the life of the system.



Coldrooms for a wide variety of applications

Hospitality



Commercial Kitchens



Fruits & Vegetables



Flight Kitchens



Dairy Products



Cloud Kitchens & Delivery



Bakery



Storage of Seafood





Butler, a brand that truly complements
Trufrost refrigeration solutions

The magnetising aroma of
good coffee



Fully Automatic Coffee Machines

Popularly also known as One-Touch Cappuccino Machines, this all new range of super-automatic coffee machines from Butler comes in 2 stunning variants that cater to the needs of busy rest-bars as well as medium and small foodservice applications such as canteens, pizzerias, bakery shops as also offices. The Swiss Touch leads the pack with an advised daily output of 200 cups or more and the Italia TurboSteam up to 100 cups a day. The special steam wand in both the models ensure you can whip up piping hot cappuccino.



Swiss Touch



- Easy to use touch panel with over 30 beverage options
- Powerful metallic brewer with high and low pressure brewing function for both espresso and regular (filter) coffee available.
- Dual water pump + double boiler system, each boiler capacity 700ml, one-touch steam/hot water
- Flat ceramic burrs , 2.0g/s coffee grinding, with bigger motor, life cycle 50000 cups+
- Pot coffee function+ brewing cycle index function, suitable to serve coffee for the people around table in hotels/restaurants etc.
- 1 steam wand
- 1 hot water wand
- Suitable for fresh & powder milk
- Self cleaning system for milk
- 1400 gm beans hopper
- Powder hopper for 600 gm milk powder or 1000 gm chocolate powder



Italia TurboSteam



- Easy to use touch panel with over 20 beverage options
- Powerful metallic brewer with high and low pressure brewing function for both espresso and regular (filter) coffee available.
- Flat ceramic burrs, 2.0g/s coffee grinding, with bigger motor, life cycle 50000 cups+
- Pot coffee function+ brewing cycle index function , suitable to serve coffee for the people around table in hotels/restaurants etc.
- 1 steam wand
- Large 8 litres water tank
- Suitable for fresh milk
- Smooth and easy to clean milk frothing system
- Intelligent self monitoring system with fault warning
- 1200 gm beans hopper

Technical Specifications



Items	Swiss Touch	Italia TurboSteam
Advised daily output	200 cups	100 cups
Rated input power	2700-3100 W	1500-1700 W
Electricals	220V/50Hz	220V/50Hz
Pump Pressure	19 Bar (2 pumps & 2 boilers)	19 Bar (2 Thermo blocks)
Water Tank Capacity	4 L + Tap Water	8L + Tap Water
Beans hopper capacity	1400g	1200g
Adjustable height of coffee spout	80-180mm	80-165mm
Ground coffee container capacity	70 portions	70 portions
Drain water tray capacity	1.5L	2L
Machine Weight	26 kg	17 kg
Dimensions (WxDXH)	340x545x610 mm	410x500x580 mm

Specifications are subject to change without prior notice due to continuous product development



Traditional Coffee Machines

Coffee connoisseurs and many coffee lovers still fall back on traditional coffee machines for a real coffee experience. Apart from allowing them to froth up piping hot cappuccino or cafe latte, these machines also offer great possibilities for baristas to do 'latte art', where some of the fully automatic machines fall short. Traditional Coffee Machines from Butler are built around elegance, reliability and high performance and reflect the finest tradition of Italian espresso.

Undici

These high quality espresso coffee machines are specially made for Butler, by La Cimbali of Italy. They are versatile, easy to use, adjust, and maintain. Made in an elegant combination of steel and black, they are ergonomic and robust. Their new thermo-syphon system is without injectors and with specific nozzles suited for sub-tropical countries. They are available in the 1 and 2 group "Coffee-to-go" versions and are designed for cups up to 14.5 cm height.



Undici A1



Undici A2



Roma 1



Roma 2

Roma

Butler's Roma range is a reflection of Italian excellence and two models are available in 1 and 2 high-raised groups, with automatic or semi-automatic dosage and 4 selection buttons plus continuous delivery. Made in an elegant combination of steel and teakwood or steel and black, they come with an automatic level control for boiler and heating up stage, thermo-siphonic heating of coffee groups and a double gauge for easy measurement and display of water as well as steam pressures.

Technical Specifications



Model	Boiler capacity (litres)	Dimensions W X D X H (mm)	Power	Electricals	Weight (kg)
Undici A1	4.9	432x598x670	3KW - 3.5KW	220-240V / 50Hz / 1Phase	33
Undici A2	10.5	712x598x570	4KW - 4.4KW	380-415V / 50 Hz /3Phase	57

Specifications are subject to change without prior notice due to continuous product development

Technical Specifications



Model	Boiler capacity (litres)	Dimensions W X D X H (mm)	Power	Electricals	Weight (kg)
Roma 1	4.0	339x475x500	1.85KW	220-240V / 50Hz / 1Phase	34
Roma 2	11.0	585x475x500	3.15KW	220-240V / 50Hz / 1Phase	47

Specifications are subject to change without prior notice due to continuous product development

Manual and On-demand Coffee Beans Grinders

Butler Professional Coffee Grinders are built in an elegant combination of steel and black and are a perfect complement to your Butler coffee machine. You can choose between two models - Brasil, a manual grinder or Kenia-Tron, an on-demand doser-grinder. They have single-bodied, hermetically sealed dosers that prevent aroma loss. The motor is equipped with a thermal protector.



Brasil-Black



Brasil



Kenia-Tron

Technical Specifications



Model	Hopper Capacity (kg)	Dispenser Capacity	Dimensions W X D X H (mm)	Power	Weight
Brasil-Black	1 kg of beans	300 gm of ground coffee	210x380x470	275W	8Kg
Brasil	1 kg of beans	300 gm of ground coffee	210x380x470	275W	8Kg
Brasil-Tron	1 kg of beans	On demand	210x380x470	275W	9Kg

Voltage: 220-240V/50Hz Specifications are subject to change without prior notice

Milk Chillers

Refrigerated unit from Trufrost with a real compressor in elegant black colour to go with your coffee machine. It preserves up to 8 (4+4) litres of milk. You can create the perfect light milk foam for trendy coffee creations by keeping the milk fresh and at a constant, cool temperature.



Frigo-Milk

Cup Warmers

The Butler electric cup warming units come in an all stainless steel construction. They have 2 cup warming shelves for preheating upto 72 cups for a real coffee experience. The special airflow ensures even heat distribution.



CW-2

Technical Specifications



Model	Capacity	Temperature	Refrigerant	External Dimensions	Internal Cavity	Power
Frigo Milk	8 Litres	1-10 °C	R600a	220x495x360mm	160x190x290mm	76W
CW-2	-	60-85 °C	-	360x320x550mm	-	14W

Voltage: 220-240V/50Hz Specifications are subject to change without prior notice



The craft behind
captivating blends





Commercial Blenders

Butler TruBlend blenders are ideal for restaurants, cafes and other commercial applications. They are perfect for crushing ice in seconds, making cocktails, frothy milkshakes, smoothies, frappes, cold coffee and more. TruBlend 2.2AQT model features an advanced acoustic enclosure that reduces blending noise by up to 80%.



Trublend 2.2 AQT



Trublend 2.2 T



Technical Specifications



Model	Power	Motor Power	Jar Capacity	Timer
TruBlend 2.2 AQT	1680W	2.2 HP	2.5 Litre	Yes
TruBlend 2.2 T	1680W	2.2 HP	2.5 Litre	Yes

Voltage: 220-240V/50Hz

Specifications are subject to change without prior notice

Commercial Cold Pressed Juicers

Butler's Commercial Whole Slow Cold Pressed Juicer comes with a robust 4 hour heavy duty motor designed to extract juices faster than traditional juicers. It expels dry pulp resulting in an enhanced juice yield. Its special masticating system presses the food, releasing their deeply entrenched nutrients and enzymes. The slow RPM ensures a richer texture of juices that retain more vitamins and minerals.

Comes with

- ◆ 1 Polyethylenimine (PEI) strainer
- ◆ 1 grey transparent ice cream strainer
- ◆ 2 grey transparent pulp containers
- ◆ 1 smoothie strainer



CPJ-600

Model	Power	Rated Working Time	Rated Interval Time	Dimensions (WxDxH)
CPJ-600	240W	4 Hours	30 min	250 x 160 x 470 mm

Voltage: 220-240V/50Hz Specifications are subject to change without prior notice due to continuous product development



Single Spindle Drink Mixers

The Butler Drink Mixers offer great versatility for mixing drinks as well as food preparation. They are ideal for mixing ice cream shakes, 'lassi' or bar drinks and are equally handy for blending eggs or mixing batter for pancakes or waffles.



Model	Power	Voltage	Dimensions (WxDxH)
DM-1F	1.5kW	220~240V/50Hz	190x160x530 mm

Specifications are subject to change without prior notice due to continuous product development

Turn fast food into a
gourmet experience!

Ventless High Speed Ovens

The Butler Ventless High Speed oven is a revolutionary appliance designed to combine three technologies- convection, accelerated air impingement and microwave. While microwaves offer fast cooking, they can often result in meals that are soggy and devoid of quality textures like crispy crusts. With Butler High Speed Ovens, this would be a thing of the past. They are designed to churn out great tasting food, quickly and consistently. They're also great space savers, reducing the need for multiple cooking appliances and the built-in catalytic converter breaks down grease-laden vapours, allowing for a ventless operation.

Typical Cook Times: Butler High Speed Ovens

Item	Concorde	Concorde Plus
9" Pizza-Fresh Dough (600g)	110 seconds	60 seconds
9" Pizza-Parbaked, Refrigerated	70 seconds	40 seconds
12" Sub Sandwich	40 seconds	20 seconds
12" Sub Sandwich (Qty 2)	50 seconds	30 seconds
6" Hamburger (Qty 2)	40 seconds	20 seconds
6" Hamburger (Qty 4)	50 seconds	30 seconds
Muffin (Qty 4)	50 seconds	30 seconds
Cinnamon Rolls (frozen, par-baked)-Qty 6	70 seconds	40 seconds
French Fries (2x170g)	160 seconds	90 seconds
Apple Strudel (300g)	120 seconds	70 seconds
Nachos (120g)	30 seconds	20 seconds
Sausages (15x56g)	150 seconds	90 seconds
Steak (600g)	330 seconds	210 seconds
Chicken Wings (8 count, Frozen)	170 seconds	100 seconds
Chicken Tenders (Frozen, 900g)	240 seconds	140 seconds
Roast Meat (block, 650g)	240 seconds	140 seconds

Butler Ventless High Speed Oven is a versatile, all-in-one cooking oven with an ability to cook, toast, grill, regenerate and bake a wide range of fresh or frozen foods, such as sandwiches, paninis, pizzas, burritos, toasties, quesadillas, samosas, fish, vegetables, kebabs, steaks and a lot more and offer the following benefits.

- Simple operation with Touchscreen control
- Up to 20 x faster preparation times
- Pre-programming on PC
- Download recipes via the USB port
- Rapid cooking with high quality repeatable results
- Ventless operation



Concorde / Concorde Plus

The little wonder from Butler

that cooks a surprisingly large variety of food
up to 20 x faster

Catalytic converter



The built-in catalytic converter breaks down grease-laden vapours, allowing for a ventless operation.



Coffee Shops



Casual Dining



Hotels & Resorts



Airports



Quick Service Restaurants



Cloud Kitchens



Theaters



Burritos



Quesadilla



Caprese Sandwich



Samosas



Burgers & Fries



Cinnamon Rolls



Lasagna



Muffins



Nachos



Pasta



Pizzas



Roasted Skewers



Panini Grills



Steaks



Wraps



Standard accessories



Oven shovel



Set of 2 baskets



Set of 2 non-stick baking pads



Baking stone



Set of 2 pans



Rack

Parameters	Concorde	Concorde Plus
Dimensions (Wx D x H)	383 X 693 X 610 mm	
Dimensions Chamber	320 x 320 x 195 mm	
Weight	65kg	77kg
Cooking Speed	10 times faster	20 times faster
100% Microwave	1-Mag/ 1100 W	2-Mag/ 2200 W
Impingement	1-heater/1600 W	2-heater/3800 W
Combi mode	1100w+1600 W	2200w+3800 W
Max Power	3500 W	6500 W
Max Current	16A	32A
Power Source	1-Ph / 220-240V / 50Hz	3-Ph / 380-440V / 50Hz
Frequency	2450MHz	
Display	Touch screen	
Temp Mode	3- mode	
Programmable Settings	432 recipes	
Program Menu	Multi-level menu capability	
Temp Setting	0-280°C in 2°C steps.	
Time Setting	00:00-59:50 in 10 second steps	
Micro Setting	0-100% in 10% steps	
Fan Setting	10-100% in 1% steps	
Edit	Can edit recipe data and images on both PC and ovens	
Load	USB port to load recipes and images	
Rack	Removable rack	
Door Opening	Pull down	
Exterior Finish	Stainless steel	
Interior Finish	304 Stainless steel	

Specifications are subject to change without prior notice due to continuous product development.



IMPORTANT: Butler High Speed Ovens require installing a type D circuit breaker for all installations.

Butler Combi Steamer
A chef's delight



Combi Steamers for Gastronomy & Pastry

Butler professional combi steamers bring an amazing reliability consistency and sturdiness at a chef's service through the use of an authentic Made in Italy product. Ovens with direct steam injection are available from 7 to 20 levels (GN 1/1 and EN) with Analog or Touch screen controls. They come in electric and gas variants with crosswise insertion of the trays, meant for chefs who expect the optimal performances both in gastronomy and pastry cooking. Butler combi steamers help you achieve perfectly even cooking results on every tray, at any level. More importantly, they don't burn a hole in your pocket.



Distinguishing features of Butler Combi Steamers

- ◆ Control panels: Simple, efficient and intuitive controls. Possibility to choose between Analog controls, Touch Screen and Multi Level Cooking
- ◆ Ergonomic door hand with opening from both sides and double snap safety lock (optional)
- ◆ Cooking chamber molded cavity in stainless steel AISI 304 with rounded corners
- ◆ Steam release valve: manual or automatic control
- ◆ Spotless chamber washing (with Touch Control Panel & Multi Level Cooking models)
- ◆ Tray holders to fit both GN 1/1 and EN trays
- ◆ Well-lit interiors
- ◆ Pitch: 67 mm

Analog Control Panel

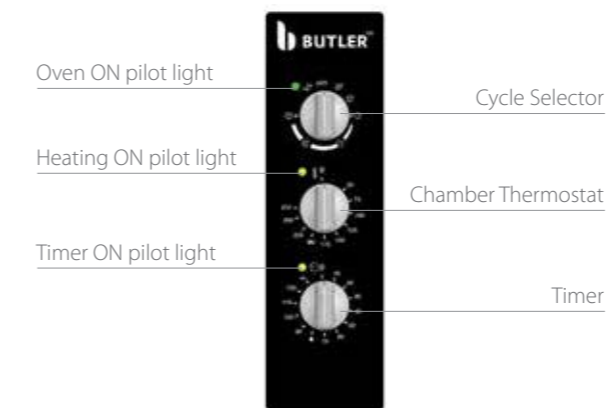

Touch Screen Control Panel

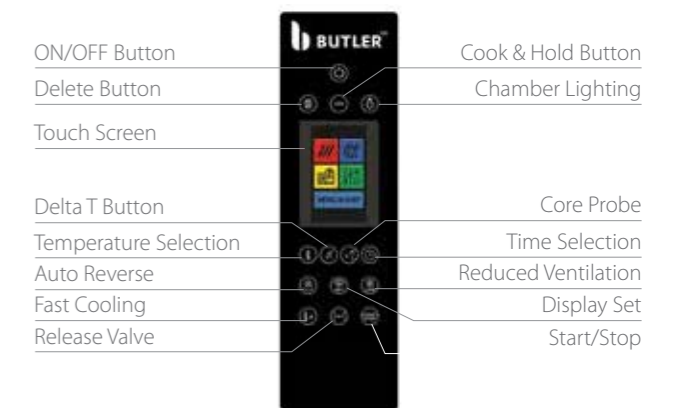

Multi Level Cooking

This feature on models ECS-007TM and GCS-007TM optimises food production during mise en place and is really handy for à la carte cooking. It allows for effective cooking of mix loads, thereby offering flexibility and speedy response. You can use each rack individually for production, increase utilisation through the use of clever mixed loads and save on both - time and energy.



ECS-020A, ECS-020T,
GCS-020A, GCS-020T



ECS-012A, ECS-012T,
GCS-012A, GCS-012T



ECS-007A, ECS-007T, ECS-007TM,
GCS-007A, GCS-007T, GCS-007TM



Vegetables

Vegetables fresh, crisp and colourful. Fresh vegetables are cooked gently, and ensure that vitamins, nutrients and colours are preserved.



Gratins, pizzas & snacks

Churns out an incredible variety of pizzas – super moist on the top, crispy on the borders and delicious at the core. It is equally easy to cook delicious pasta, rice and idlis to suit the local palate.



Desserts & cakes

Incredibly multifunctional – perfect for preparing desserts. Whether you bake cakes or poach pears in red wine, it's ingenious: with the 2 in 1 combination you can bake on one shelf and poach on another at the same time.



All kinds of bread

Scores of baguettes can be baked at the same time in a Butler combi. The special auto-reverse feature ensures that all bakery items turn out absolutely even, from the top to the bottom shelf.



Fish, meat & kebabs

Cooks fish, meat and vegetables at the same time - with no aroma transfer.



Grill & pan fry

Grill scores of cutlets in minutes. Juicy steaks get a delicious barbecue look.



Technical Specifications



Model	Power	Voltage	Gas Power	Gas Consumption	GN/EN* Trays	Dimensions W x D x H (mm)	Control Panel	Weight
ECS-007A	11.5Kw	400V 3N/50Hz	-	-	7 x 1/1	920 x 730 x 900	Analog	105kgs
ECS-007T	12.3Kw	400V 3N/50Hz	-	-	7 x 1/1	950 x 790 x 870	Touch Screen	123kgs
ECS-007TM	12.3Kw	400V 3N/50Hz	-	-	7 x 1/1	950 x 790 x 870	Touch Screen	123kgs
ECS-012A	17.3Kw	400V 3N/50Hz	-	-	12 x 1/1	920 x 730 x 1230	Analog	128kgs
ECS-012T	16.9Kw	400V 3N/50Hz	-	-	12 x 1/1	950 x 790 x 1190	Touch Screen	150kgs
ECS-012TM	18.4Kw	400V 3N/50Hz	-	-	12 x 1/1	840 x 996 x 1275	Touch Screen	150kgs
ECS-020T	52Kw	400V 3N/50Hz	-	-	20 x 1/1	970 x 1350 x 1880	Touch Screen	150kgs
GCS-007A	0.3Kw	230V 1N/50Hz	14.5Kw	1.143 Kg/hr	7 x 1/1	920 x 790 x 900	Analog	116kgs
GCS-007T	0.6Kw	230V 1N/50Hz	14.5Kw	1.143 Kg/hr	7 x 1/1	950 x 790 x 870	Touch Screen	137kgs
GCS-007TM	0.6Kw	230V 1N/50Hz	14.5Kw	1.143 Kg/hr	7 x 1/1	950 x 790 x 870	Touch Screen	137kgs
GCS-012A	0.5Kw	230V 1N/50Hz	20.5Kw	1.617 Kg/hr	12 x 1/1	920 x 790 x 1250	Analog	145kgs
GCS-012T	0.6Kw	230V 1N/50Hz	20.5Kw	1.617 Kg/hr	12 x 1/1	950 x 790 x 1190	Touch Screen	192kgs
GCS-012TM	0.6Kw	230V 1N/50Hz	20.0Kw	1.617 Kg/hr	12 x 1/1	840 x 1026 x 1294	Touch Screen	192kgs
ECS-020A	30 kW	400V 3N/50Hz	-	-	20 x 1/1	970 x 1030 x 1880	Analog	390kgs
ECS-020T	30 kW	400V 3N/50Hz	-	-	20 x 1/1	970 x 1030 x 1880	Touch Screen	390kgs
GCS-020A	1.5 kW	230V 1N/50Hz	29 kW	-	20 x 1/1	966 x 1086 x 1886	Analog	360kgs
GCS-020T	1.5 kW	230V 1N/50Hz	29 kW	-	20 x 1/1	966 x 1086 x 1886	Touch Screen	360kgs

Specifications are subject to change without prior notice due to continuous product development
*GN 1/1 Tray (530 x 325mm), EN Tray (600 x 400mm)

Control Panel Specifications

Oven Model	With Analog	With Touch Control
Convection with Ventilation	50-270°C	20-270°C
Combi with Direct Steam	50-270°C	20-270°C
Steam	50-100°C	20-100°C
Autoreverse	Standard	Standard
Double Ventilation speed	Standard	Standard
Core Probe	Not Available	Standard
Delta T	Not Available	Standard
Automatic Programs	Not Available	300 programs 6 phases
Automatic preheating	Not Available	Standard
USB connection	Not Available	Standard
Automatic washing	Not Available	Standard with Liquid detergent

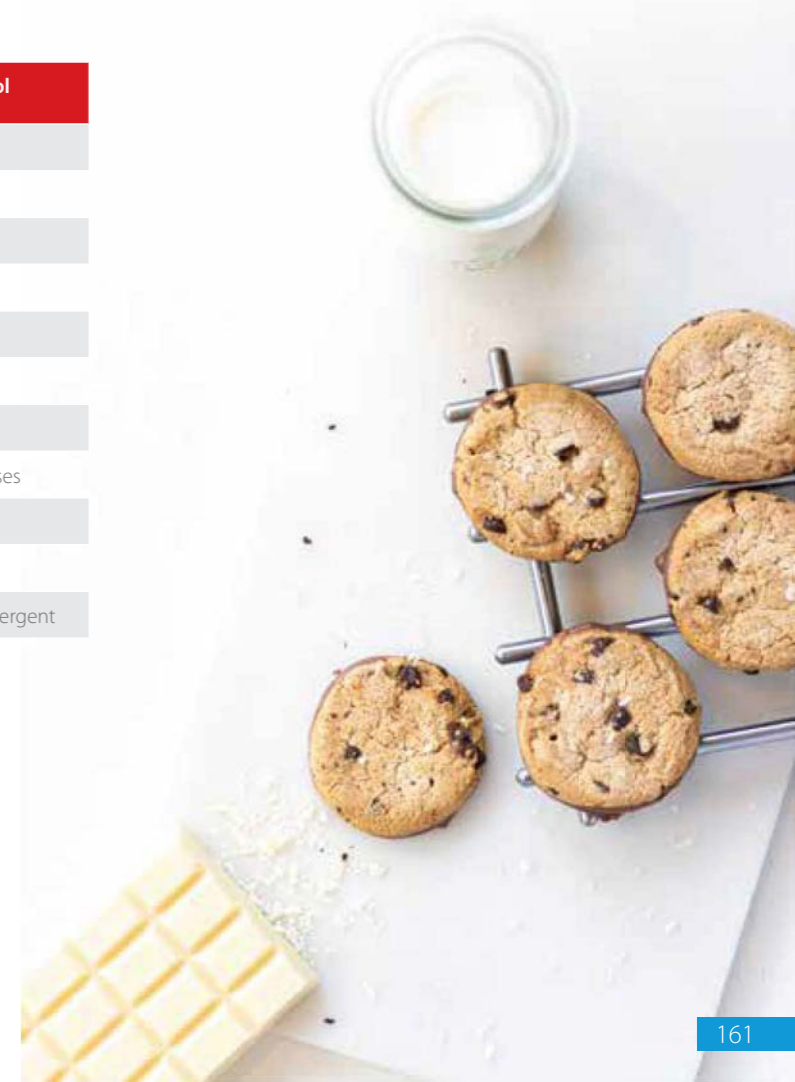

Get great baking
results consistently





Models Available in Electric, Gas and Diesel Versions

Rotary Rack Ovens - 32 Trays

The Butler Rotary Rack Ovens are designed to allow for efficient wheeling of a pan rack full of goods right into the oven for baking. They offer great labour savings due to reduced product handling and are suitable for baking large quantities of cakes, breads, biscuits and a vast variety of bakery products. The advanced hot air circulating motor is configured to distribute the heat evenly inside the machine. In addition, the drive motor rotates the trolley tray to make the heating effect more pronounced and uniform. The inside and outside body is in high quality stainless steel. They come in electric, gas and diesel variants.

- ◆ Unique double positioning door bolt technology prevents heat loss through the door
- ◆ Double fan with a large air duct for effective baking
- ◆ Advanced Italian burner ensures reliability and consistency

Rotary Rack Ovens - 16 Trays

The Butler Rotary Rack Ovens are designed to allow for efficient wheeling of a pan rack full of goods right into the oven for baking. They offer great labour savings due to reduced product handling and are suitable for baking large quantities of cakes, breads, biscuits and a vast variety of bakery products. The advanced hot air circulating motor is configured to distribute the heat evenly inside the machine. In addition, the drive motor rotates the trolley tray to make the heating effect more pronounced and uniform. The inside and outside body is in high quality stainless steel. They come in electric, gas and diesel variants.

- ◆ Unique double positioning door bolt technology prevents heat loss through the door
- ◆ Double fan with a large air duct for effective baking
- ◆ Advanced Italian burner ensures reliability and consistency



RO-16

Models Available in Electric, Gas and Diesel Versions



Technical Specifications - Rotary Rack Ovens



Product	Model	Rated Power	Gas Power	Dimensions (W x D x H)	Electricals	Weight	Remarks
Rotary Oven (Electric)	RO-32E	57kw	-	1660 x 2730 x 2400 mm	380V / 50 Hz	1950kg	32 Trays
Rotary Oven (Gas)	RO-32G	3.1kw	93379 - 107745 BTU/hr	1660 x 2730 x 2400 mm	380V / 50 Hz	1950kg	32 Trays
Rotary Oven (Diesel)	RO-32D	3.1kw	-	1660 x 2730 x 2400 mm	380V / 50 Hz	1950kg	32 Trays
Rotary Oven (Electric)	RO-16E	33kw	-	1280 x 2250 x 2400 mm	380V / 50 Hz	1180kg	16 Trays
Rotary Oven (Gas)	RO-16G	2.2kw	64647 - 89787.5 BTU/hr	1280 x 2250 x 2400 mm	380V / 50 Hz	1180kg	16 Trays
Rotary Oven (Diesel)	RO-16D	2.2kw	-	1280 x 2250 x 2400 mm	380V / 50 Hz	1180kg	16 Trays

Specifications are subject to change without prior notice due to continuous product development



Luxury Deck Ovens (2 trays on each deck)

These high-end Butler electric & gas based Deck Ovens come with microcomputer controller & steam generator. The outer cabinet is finished in brushed stainless. They are specially designed for baking bread, cakes, croissants, pastries and more. Using infrared radiant heating tube, they bake the food rapidly and uniformly. The required temperature can be set up to 400°C and controlled automatically. Ideal for hotels, restaurants, bakehouses and bread shops, each deck can accommodate 2 EN trays inside the baking chamber.



Electric: EFO-1D-2C
Gas: GFO-1D-2C



Electric: EFO-2D-4C
Gas: GFO-2D-4C



Electric: EFO-3D-6C
Gas: GFO-3D-6C

Electric: EFO-1D-2C
Gas: GFO-1D-2C



Electric: EFO-2D-4C
Gas: GFO-2D-4C

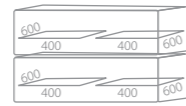

Electric: EFO-3D-6C
Gas: GFO-3D-6C

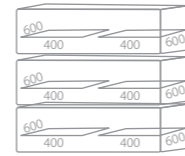

Technical Specifications



Product	Model	Power/Gas Power	Weight	Dimensions (W x D x H)	Electricals	Temperature	Trays
Electric Single Deck Oven	EFO-1D-2C*	6.8 kW	130 kgs.	1355 x 960 x 700 mm	1-220V / 50Hz	0 ~ 400°C	2 x EN Trays
Electric Two Deck Oven	EFO-2D-4C*	13.6 kW	220 kgs.	1355 x 960 x 1255 mm	3-380V / 50 Hz	0 ~ 400°C	4 x EN Trays
Electric Three Deck Oven	EFO-3D-6C*	20.4 kW	310 kgs.	1355 x 960 x 1645 mm	3-380V / 50 Hz	0 ~ 400°C	6 x EN Trays
Gas Single Deck Oven	GFO-1D-2C*	42651.9 BTU/Hr	130 kgs.	1355 x 960 x 720 mm	1-220V / 50Hz	0 ~ 400°C	2 x EN Trays
Gas Two Deck Oven	GFO-2D-4C*	85303.8 BTU/Hr	220 kgs.	1355 x 960 x 1375 mm	1-220V / 50Hz	0 ~ 400°C	4 x EN Trays
Gas Three Deck Oven	GFO-3D-6C*	127955.7 BTU/Hr	310 kgs.	1355 x 960 x 1835 mm	1-220V / 50Hz	0 ~ 400°C	6 x EN Trays

Specifications are subject to change without prior notice due to continuous product development
* These models are microcomputer controlled & come with a steam generation feature.

Gas based ovens can work on LPG.

Deck Ovens - Premia Series (2 trays on each deck)

These Butler electric & gas based Deck Ovens come with simple electromechanical temperature controllers, digital timers but without the steaming function. The outer cabinet is finished in brushed stainless. They are specially designed for baking bread, cakes, pastries and more. Using infrared radiant heating tube, they bake the food rapidly and uniformly. The required temperature can be set up to 400°C and controlled automatically. Ideal for hotels, restaurants, bakehouses and bread shops, each deck comes with 2 EN trays.



Electric: EDO-1D-2T Premia
Gas: GDO-1D-2T Premia



Electric: EDO-2D-4T Premia
Gas: GDO-2D-4T Premia



Electric: EDO-3D-6T Premia
Gas: GDO-3D-6T Premia

Technical Specifications



Product	Model	Power/Gas Power	Weight	Dimensions (W x D x H)	Cavity Dimensions (W x D x H)	Electricals	Temperature	Trays
Electric Single Deck Oven	EDO-1D-2T Premia	6.6 kW	85KG	1250 x 845 x 615mm	870 x 670 x 200mm	1-220V / 50Hz	0 ~ 400°C	2 x EN Trays
Electric Two Deck Oven	EDO-2D-4T Premia	13.2 kW	150KG	1250 x 845 x 1220mm	870 x 670 x 200mm	3-380V / 50 Hz	0 ~ 400°C	4 x EN Trays
Electric Three Deck Oven	EDO-3D-6T Premia	19.8 kW	200KG	1250 x 845 x 1615mm	870 x 670 x 200mm	3-380V / 50 Hz	0 ~ 400°C	6 x EN Trays
Gas Single Deck Oven	GDO-1D-2T Premia	13935.6 BTU/Hr	135KG	1340 x 900 x 660mm	890 x 690 x 200mm	1-220V / 50Hz	0 ~ 400°C	2 x EN Trays
Gas Two Deck Oven	GDO-2D-4T Premia	18580.8 BTU/Hr	250KG	1340 x 900 x 1380mm	890 x 690 x 200mm	1-220V / 50Hz	0 ~ 400°C	4 x EN Trays
Gas Three Deck Oven	GDO-3D-6T Premia	27871.2 BTU/Hr	370KG	1340 x 900 x 1775mm	890 x 690 x 200mm	1-220V / 50Hz	0 ~ 400°C	6 x EN Trays

Specifications are subject to change without prior notice due to continuous product development

Gas based ovens can work on LPG.



Deck Ovens - Premia Series (3 trays on each deck)

These Butler electric & gas based Deck Ovens come with simple electromechanical temperature controllers, digital timers but without the steaming function. The outer cabinet is finished in brushed stainless. They are specially designed for baking bread, cakes, pastries and more. Using infrared radiant heating tube, they bake the food rapidly and uniformly. The required temperature can be set up to 400°C and controlled automatically. Ideal for hotels, restaurants, bakehouses and bread shops, each deck comes with 3 EN trays.



Electric: EFO-2D-4C
Gas: GFO-2D-4C



Electric: EFO-3D-6C
Gas: GFO-3D-6C

Technical Specifications



Product	Model	Power/Gas Power	Weight	Dimensions (W x D x H)	Cavity Dimensions (W x D x H)	Electricals	Temperature	Trays
Electric Two Deck Oven	EDO-2D-6T Premia	16.8 kW	230KG	1670 x 845 x 1220mm	1290 x 670 x 200mm	3-380V / 50 Hz	0 ~ 400°C	6 x EN Trays
Electric Three Deck Oven	EDO-3D-9T Premia	25.2 kW	280KG	1670 x 845 x 1640mm	1290 x 670 x 200mm	3-380V / 50 Hz	0 ~ 400°C	9 x EN Trays
Gas Two Deck Oven	GDO-2D-6T Premia	120W / 16.6KW/H	250KG	1760 x 900 x 1370mm	1310 x 690 x 200mm	1-220V / 50Hz	0 ~ 400°C	6 x EN Trays
Gas Three Deck Oven	GDO-3D-9T Premia	180W / 25KW/H	370KG	1760 x 900 x 1800mm	1310 x 690 x 200mm	1-220V / 50Hz	0 ~ 400°C	9 x EN Trays

Specifications are subject to change without prior notice due to continuous product development

Gas based ovens can work on LPG.





Proofing Cabinets

Proofing is the final step in making dough before baking, when you allow the dough to rise via the fermentation of yeast. Since dough rises best in warm and humid environments, the Butler Bakery Proofer with humidification allow you to set the perfect temperature and humidity levels to get consistent, repeatable results. Constructed in quality stainless steel, you can choose between two models that can accommodate 16 & 32 trays respectively (trays not supplied with the machines).



Electric Ovens & Proofers

This unified range of Butler Electric Ovens cum Proofers come in two variants - a 1 deck/ 2 tray or a 2 deck/4 tray electric oven built atop a 12 tray proofer. The outer cabinet is finished in brushed stainless. The oven is designed for baking bread, cakes, pastries and more. The required temperature can be set up to 400°C and controlled automatically. The 2 door proofer section at the bottom allows you to set the perfect temperature and humidity levels for consistent, repeatable results and can accommodate 12 pans (not supplied with the machines).



PC-8 Premia



PC-16 Premia



PC-32 Premia

Technical Specifications - Electric Ovens & Proofers



Product	Model	Power/ Gas Pressure	Weight	Dimensions (W x D x H)	Internal Dimensions of Each Oven (W x D x H)	Electricals	Temperature
1 Deck 2 Trays Electric Oven With 12 Tray Proofer	OVP-1212	9.2kW	125 kgs.	1300 x 830 x 1420mm	870 x 670 x 200mm	380V / 50 Hz	0-400°C (Oven) / 0-110°C (Proofer)
2 Deck 4 Trays Electric Oven With 12 Tray Proofer	OVP-1224	15.8kW	210 kgs.	1300 x 830 x 1815mm	870 x 670 x 200mm	380V / 50 Hz	0-400°C (Oven) / 0-110°C (Proofer)
Single Door Proofing Cabinet - 8 Trays	PC-8 Premia	0.5kW	-	838 x 745 x 830 mm	639 x 487 x 674 mm	220V / 50 Hz.	0-110°C
Tall Single Door Proofing Cabinet - 16 Trays	PC-16 Premia	2.6kW	50 kgs.	510 x 690 x 1910 mm	500 x 640 x 1545 mm	220V / 50 Hz.	0-110°C
Tall Single Door Proofing Cabinet - 32 Trays	PC-32 Premia	2.8kW	90 kgs.	1010 x 690 x 1910 mm	1000 x 640 x 1545mm	220V / 50 Hz.	0-110°C

Specifications are subject to change without prior notice due to continuous product development

Trays not supplied with the machines.

Convection Ovens with Steam (Electric & Gas) - 10 Trays

These convection ovens with steam regulation are ideal for bakeries, snack bars and cake shops that need to heat up or cook croissants, pastry, bread or simple dishes. You can choose between electric or gas versions with a side opening strong hinged door, simple electromechanical controls, 10 x 1 EN trays with a pitch of 99mm, they come with a stainless steel AISI 304 cooking chamber.



ECO-10D Premia, GCO-10D Premia



Technical Specifications

Model	Power	Voltage	Gas Consumption (kg/ hr)	External Dimensions W x D x H (mm)	Internal Dimensions W x D x H (mm)	Tray Size W x D (mm)	Weight
ECO-10D Premia	14.6kw	380V/50Hz	-	950 x 1255 x 1690	420 x 670 x 1140	600 x 400	240Kg
GCO-10D Premia	1.2kw	220V/50Hz	32516.4 BTU/Hr	973 x 1423 x 1874	420 x 670 x 1140	600 x 400	320Kg

Specifications are subject to change without prior notice due to continuous product development
Trays not supplied with the machines.

Electric Convection Ovens - 4 Trays

Butler convection ovens allow you to bake like a professional. They are designed for cooking or reheating croissants, chocolate buns, pastries or cookies, lasagna, baked potatoes and a wide variety of fresh frozen or pre-raised savories. ECO-920S ovens come with a steam regulation and advanced computer controls, 4 x 1 EN trays with an average pitch of 70-90 mm, they come with a stainless steel AISI 304 cooking chamber. The ECO-28 (New) comes with simple, easy to operate controls.



ECO-920S



ECO-28 (New)

Technical Specifications

Model	Power	Voltage	Trays	Temperature Range	External Dimensions W x D x H (mm)	Internal Dimensions W x D x H (mm)	Tray Size W x D (mm)	Control Panel
ECO-920S	6.0kw	220V/50Hz	4	50°C -300°C	920 x 815 x 600	645 x 455 x 420	580 x 400	Touch Pad
ECO-920S	6.0kw	380V/50Hz	4	50°C -300°C	920 x 815 x 600	645 x 455 x 420	580 x 400	Touch Pad
ECO-28 (New)	4.5kW	220V/50Hz	4	0°C -350°C	670 x 650 x 470	460 x 370 x 350	440 x 318 / 4pans	Analogue

Specifications are subject to change without prior notice due to continuous product development
Trays not supplied with the machines.





Dough Sheeters

Butler Dough Sheeters are designed to take a ball of dough, roll it and stretch it out to a thickness ranging from 0.5 mm to 30 mm. They come with special motors and work on a two-way pressing mechanism that avoids tearing of the dough whilst optimising the output. Available in two versions - table top or with a stand, they are equipped with a safety shield and designed to operate smoothly, safely and reliably. All parts that come in contact with food are made of stainless steel or are specially plated to meet the required hygiene standards for food. When not in use, both sides of the conveyor table fold up for storage in the floor standing model.



DS-520FS



DS-520

Technical Specifications - Dough Sheeters

Product	Model	Power	Weight	Dimensions with Trays Pulled-out (W x D x H)	Dimensions without trays Pulled-out (W x D x H)	Remarks
Dough Sheeter	DS 520FS	0.75 kW	255 kgs.	2780 x 875 x 1230 mm	2080 x 875 x 1230 mm	133 rpm / Roller length 520 mm
Dough Sheeter	DS-520	0.75 kW	216 kgs.	2780 x 875 x 650 mm	2080 x 875 x 650 mm	133 rpm / Roller length 520 mm

Voltage: 220-240V/50Hz

Specifications are subject to change without prior notice due to continuous product development

Pizza Dough Rollers

Butler Pizza Dough Rollers are designed to compress the dough between the rotating rollers. They are ideal for producing smooth and consistent dough sheets in the required thickness. Two pairs of parallel and adjustable rollers to allow for variation in thickness of pizza dough and for either square or rectangular sheet. You can obtain a round sheet by just turning the dough around 90° once it comes out of the upper rollers and before it enters the lower rollers.



PDR-40

Technical Specifications

Product	Model	Power	Weight	Dimensions (W x D x H)	Electricals	Remarks
Pizza Dough Roller	PDR-40	0.37 kW	39 kgs.	540 x 550 x 650 mm	220V / 50 Hz.	Pizza Diameter 400 mm / Dough Weight 50g - 500g

Specifications are subject to change without prior notice due to continuous product development





Table Top Tilt-head Mixers

The Butler B-5 & B-7 stand mixer has a 300-watt motor, stainless steel bowl with ergonomic handle, pouring shield and a tilt-back mixer head design that provides easy access to bowl and beaters.

- ◆ 10-Speed Solid-State Control



B-5, B-7



Wire Whip

- Cooks dough
- Cake batter
- Dips & sauces



Flat Beater

- Whipped cream
- Egg Whites
- Cake batter



'C' Dough Hook

- Yeast Dough
- Mixes
- Kneads

Technical Specifications



Model	Bowl Volume	Power	Max Kneading Capacity	Mixing Speed (rpm)	Dimensions (W x D x H) in mm	Electricals
B-5	5 ltrs.	0.3 KW	0.5 - 0.8 kgs.	45 ~ 260	230x350x400	220V/50 Hz/ 1 Ph
B-7	7 ltrs.	0.32 KW	0.5 - 1.5 kgs.	45 ~ 260	400x250x410	220V/50 Hz/ 1 Ph

Specifications are subject to change without prior notice due to continuous product development

Planetary Mixers

Butler Planetary Mixer features a fixed, non-rotating bowl that is latched onto the base of the machine and can be raised into the mixing position, and inversely lowered to remove it. These mixers offer great versatility due to different attachments they come with. Often, bakers use the paddle attachment for blending or creaming products. This includes pie crust dough, scones, cookie dough or cake filling. The whip attachment is commonly used to aerate mixtures such as meringue, sponge cake, whipped cream, and mousse. And, the dough hook attachment is typically used in pizza shops and small bread bakeries. Like in the cosmic planetary movement, the beaters in these mixers move like planets in the bowl so that the food is mixed thoroughly. They are simple to operate, easy to clean and all parts are made of quality stainless steel to ensure that they meet the required hygiene standards for food.



PM-10, PM-20



PM-30, PM-40



PM-60

Technical Specifications



Model	Bowl Volume	Power	Max Kneading Capacity	Mixing Speed (rpm)	Weight	Dimensions (W x D x H) in mm	Electricals
PM-10	10 ltrs.	0.6kw	2.5 kgs.	148/244/480	45KG	470x420x620	220V/50 Hz/ 1 Ph
PM-20	20 ltrs.	1.1kw	5 kgs.	462/317/197	65KG	540x470x810	220V/50 Hz/ 1 Ph
PM-30	30 ltrs.	1.5KW	7 kgs.	462/317/197	71KG	620x520x890	220V/50 Hz/1 Ph
PM-40	40 ltrs.	2.1KW	9 kgs.	520/187/120	170KG	600x750x1100	380V/50 Hz/3 Ph
PM-60	60 ltrs.	2.3KW	25 kgs.	458/221/114	400KG	600x750x1100	380V/50 Hz/3 Ph

Specifications are subject to change without prior notice due to continuous product development

Spiral Mixers

Butler Spiral Mixers are specially designed for dough mixing application in bakeries, hotels and restaurants. The main function of the spiral mixer is to gently mix bread dough, allowing it to develop the proper gluten structure, while not overworking the dough. In the spiral mixing methodology, both the mixer and bowl revolve simultaneously, thus giving an enhanced mixing effect. The benefit to this action is that the spiral hook is kneading only a portion of the whole dough mass at a given time. This keeps friction heat low, providing a more homogeneous mix. Typically, spiral mixers do not have interchangeable attachments. Most commonly used for mixing bread dough, spiral mixers are capable of handling very stiff dough with low hydration levels; and high hydration dough types such as ciabatta. They come with a safety cover and all parts that come in contact with food are made of stainless steel.



SM-20, SM-20T,



SM-34T



SM-40, SM-45T

Technical Specifications



Model	Bowl Volume	Power	Max Kneading Capacity	Mixing Speed (rpm)	Bowl Speed (rpm)	Dimensions (W x D x H) in mm	Electricals	Weight
SM-20	20 ltrs.	0.75 KW	8 kgs.	185	15	380 x 690 x 730	220V/50 Hz/ 1 Ph	70KG
SM-20T	20 ltrs.	1.5KW	8 kgs.	150/200	15/20	390 x 730 x 900	220V/50 Hz/ 1 Ph	90KG
SM-34T	34 ltrs.	1.5KW	12 kgs.	150/200	15/20	435 x 730 x 900	220V/50 Hz/ 1 Ph	100KG
SM-40	40 ltrs.	1.1/2.2 KW	16 kgs.	101/202	8/16	480 x 870 x 935	380V/50 Hz/3 Ph	127KG
SM-45T	45 ltrs.	3.0KW	16 kgs.	150/200	15/20	480 x 800 x 970	220V/50 Hz/1 Ph	115KG
SM-200	200 ltrs.	5/7.5KW	75 kgs.	210/107	16	950 x 1332 x 1510	380V/50 Hz/3 Ph	675KG

Specifications are subject to change without prior notice due to continuous product development

Dough Dividers

Butler Automatic Dough Dividers are specially designed to take a large batch of dough and portion it out into equally sized and weighted balls of dough for consistent results when making pies, breads, or even pizza crusts. Made in high quality stainless steel, these stable, low noise machines work on a hydraulic transmission, capable of dividing the dough into 36 pieces (30- 100gm) at one go. They are mounted on heavy duty castors for ease of mobility.



DD-36

Bread Slicers

Butler Bread Slicers are compact, easy to operate, back loading machines that are ideal for slicing upto 36 cms long bread loafs in a safe and efficient manner and are suitable for any bakery. The press plate can be adjusted to suit the bread height of 16 cms. The machines are easy to clean after use so as to maintain requisite hygiene levels. They can cut 31 slices of 1.2 cms thickness in one go.

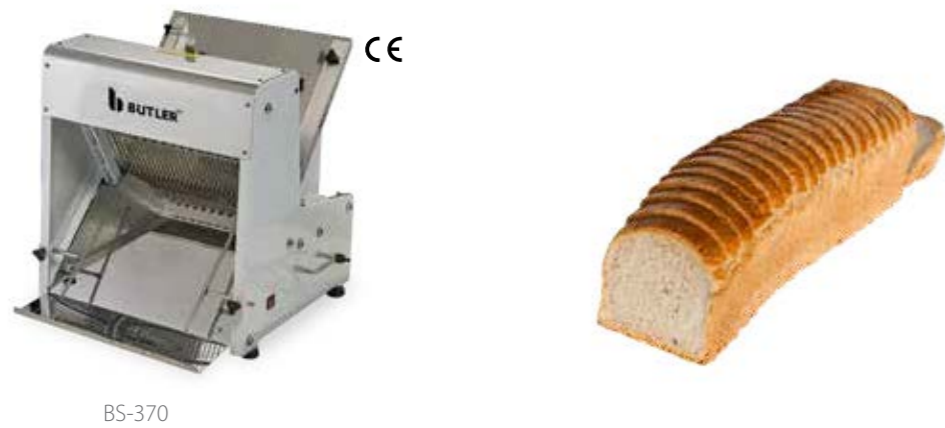

BS-370

Technical Specifications



Product	Model	Power	Weight	Dimensions (W x D x H)	Electricals	Remarks
Dough Divider	DD-36	1.5 kW	200 kgs.	520 x 420 x 1400 mm	220V / 50 Hz.	36 pcs. (30 - 100 gms.)
Bread Slicer	BS 370	0.25 kW	48 kgs.	515 x 625 x 585 mm	220V / 50 Hz.	31 pcs. of 12mm / Max length 36cm / Max width 16cm

Specifications are subject to change without prior notice due to continuous product development



Building **safer, cooler**
& **greener** kitchens



Commercial Induction Systems

Butler's innovative commercial induction systems are designed to take the food service experience to a whole new level with advanced range of induction warmers, cooktops, woks, built in induction trolleys and fryers. Professional chefs in commercial kitchens can now enjoy enhanced productivity through faster cooking, substantial energy savings but most of all, a cooler and safer kitchen.

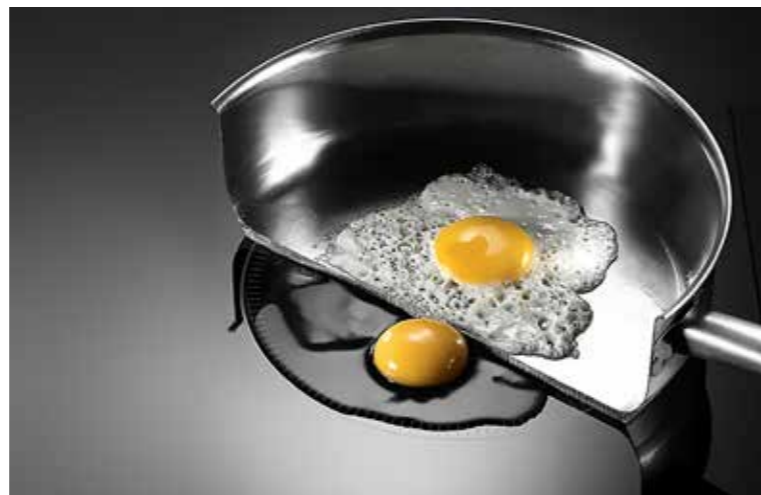

Working Principle of Induction Systems

Induction cooking uses electric currents to directly heat pots and pans through magnetic induction. Instead of using thermal conduction (a gas or electric element transferring heat from a burner to a pot or pan), induction heats the cooking vessel itself almost instantly.

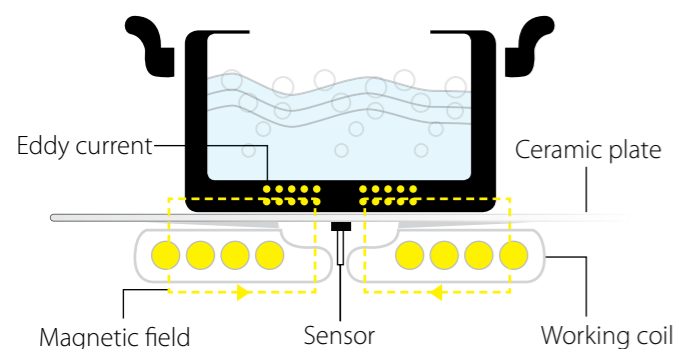

Induction heating uses electromagnetic energy to heat cookware made of magnetic material such as stainless steel, iron, nickel or various alloys. The coils produce a high frequency alternating magnetic field when turned on, ultimately flowing through the cookware. The metal molecules are attracted in different directions as the current alternates, causing the cookware to become hot. Since the cooktop's glass ceramic surface contains no magnetic material, it is unaffected by the magnetic field.

Benefits of Induction Cooking

Induction cooking devices release less heat into the room, use less fuel, and finally, you can enjoy a cleaner, safer, cooler, and more efficient kitchen, with lower energy bills.



Faster



Safer



Energy Saving



Easy to Clean



Cooler

% Energy Delivered to Pan

Butler induction systems are 90% efficient, meaning that 90% of the energy consumed is delivered to the pan. This is unmatched by gas (typically 40%) or traditional electrically powered cooking devices (typically 50%).

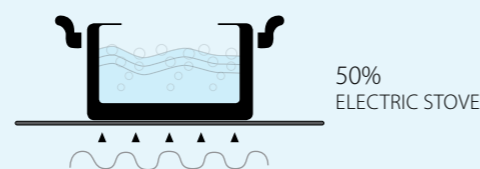

Countertop Induction Warming Trays

These portable induction warming and holding trays from Butler keep food at the right temperature while improving your presentation and overall quality. No flames or hot surfaces provide for a safer, cooler kitchen making it ideal for catering as well as buffet applications.



CIW-1.0

- Glass hob
- Stainless steel body with two stainless steel handles
- Power regulation knob
- Temperature display on the right corner of the glassplate
- Electronic overheating protection

Drop in Induction Warmers

Butler drop in induction warming and holding systems keep food at the right temperature while improving your presentation and overall quality and are ideal for catering application as well as buffet restaurants. No flames or hot surfaces provide for a safer, cooler kitchen. They are a boon for modern day buffets making the food warming more attractive, safe and free of odours caused by burners.

- Glass hob
- Stainless steel body
- Power regulation knob
- Temperature display on the right corner of the glassplate
- Electronic overheating protection

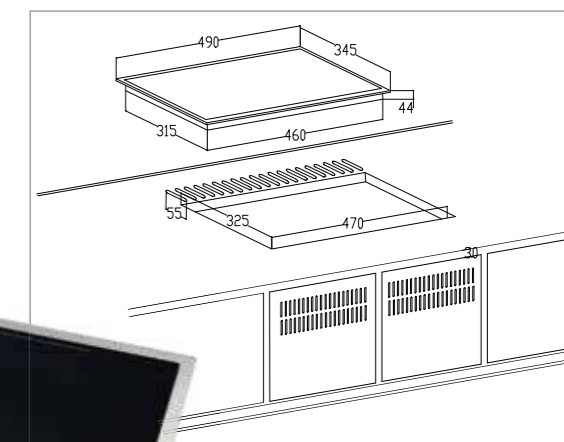

DIW-1.0

Cut-out

Technical Specifications

Model	Voltage	Power	Temperature Range	Dimensions (wxdxh)	Cut-out Dimensions (wxd)
CIW-1.0	220-240V/50Hz	1000W	40°C - 100°C	530 x 335 x 61mm	-
DIW-1.0	220-240V/50Hz	1000W	40°C - 100°C	490 x 345 x 60.5mm	325 x 470mm

Specifications are subject to change without prior notice





Drop in Induction Hobs & Woks

Butler drop-in cooktops & drop-in woks snugly fit in your kitchen counters and heat food evenly, quickly, efficiently, and are easy-to-clean. They are great for show kitchens and are designed to handle heavy duty usage. No flames or hot surfaces provide for a safer, cooler kitchen.

Key Features

- Glass hob/wok
- Stainless steel body
- Power regulation by touch control
- 1-10 power levels (500 - 3500W)
- 1-10 temperature setting

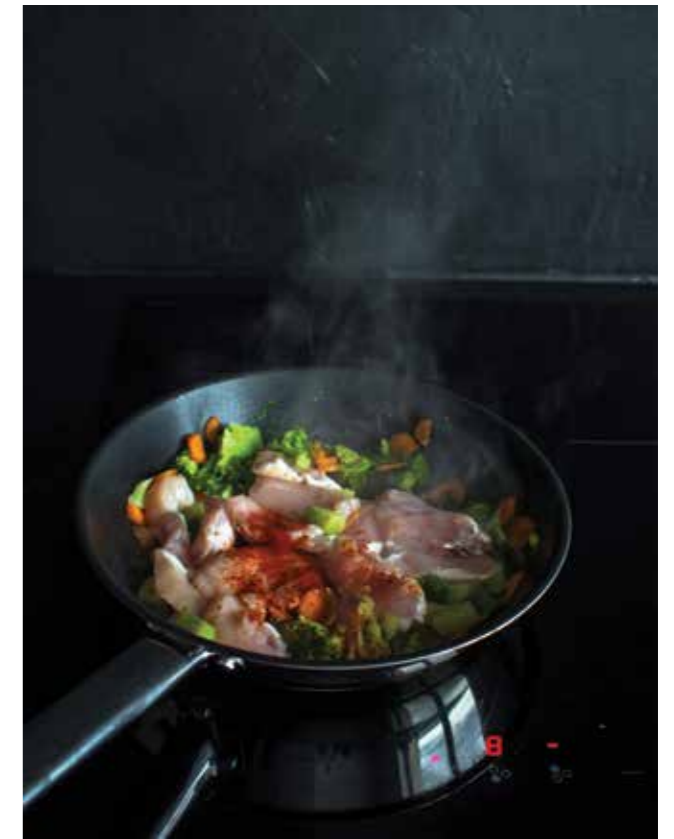

Countertop Induction Hobs & Woks

Butler portable cooktops & countertop woks heat food evenly, quickly, and efficiently, with easy-to-clean surfaces and energy efficient technology. They are designed for medium to heavy duty cooking needs and can be placed on kitchen counters for both - back of the house and interactive cooking applications. No flames or hot surfaces provide for a safer, cooler kitchen. They come in 3.5KW (220V/ Single phase) and 5KW (380 V/ 3 Phase) variants.

Key Features

- Glass hob/wok
- Stainless steel body
- Touch control
- Timer, LED display (0-180 minute)
- Electronic overheating protection



DIH-3.5 (New)



DIW-3.5

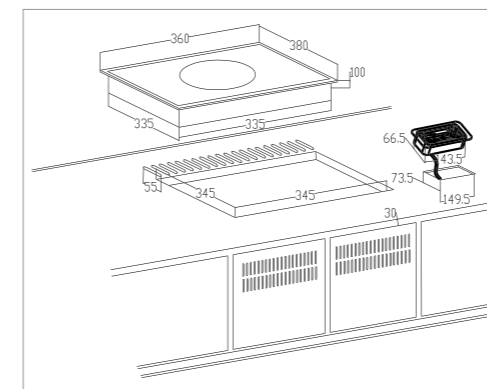

Cut-out

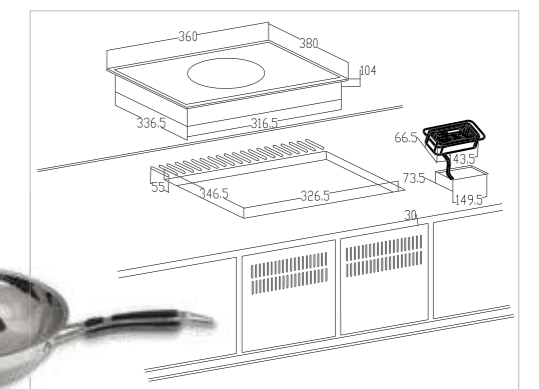

Cut-out

Technical Specifications



Model	Voltage	Power	Temperature Range	Dimensions (wxdxh)	Power Levels	Temperature Setting	Utensil Size
CIH-3.5	220 / 50Hz / 1Ph	3500W	60°C - 240°C	425 x 330 x 105mm	500-3500W (1-10)	1 - 10	120-360mm
CIW-3.5	220 / 50Hz / 1Ph	3500W	60°C - 240°C	425 x 340 x 135mm	500-3500W (1-10)	1 - 10	120-360mm
CIH-5.0	380V / 50Hz / 3Ph	5000W	60°C - 240°C	398 x 515 x 168mm	500-5000W (1-10)	1 - 15	120-400mm
CIW-5.0	380V/50Hz / 3Ph	5000W	60°C - 240°C	398 x 515 x 183mm	500-5000W (1-10)	1 - 15	120-400mm

Specifications are subject to change without prior notice

Technical Specifications



Model	Voltage	Power	Temperature Range	Dimensions (wxdxh)	Cut-out Dimensions (wxd)
DIH-3.5 (New)	220-240V/50Hz	3500W	60°C - 240°C	370 x 390 x 120mm	350 x 330mm
DIH-3.5	220-240V/50Hz	3500W	60°C - 240°C	360 x 380 x 125mm	345 x 345mm
DIW-3.5	220-240V/50Hz	3500W	60°C - 240°C	360 x 380 x 120mm	346.5 x 326.5mm

Specifications are subject to change without prior notice



The pleasures of outdoor cooking, or in-room dining thoughtfully enhanced by Butler Induction

Built in Induction Trolleys

You can now take the induction cooking experience to the next level for your guests with Butler Built in Induction Trolleys. Aside of being safe, fast and energy efficient, these can leave quite an impression when used for outdoor catering/cooking, interactive parties and even room service.

Key Features

- Moveable induction cooker built in trolley
- Power regulation by touch control
- Electronic overheating protection
- Double plate separately controllable (BIT 02):
First: 500-2000W (0-180mins timer)
Second: 500-1500W (0-180 mins timer)



BIT 01



BIT 02

Technical Specifications



Model	Voltage	Power	Temperature Range	Trolley Size (wxdxh)	Glassplate Size (wxd)
BIT 01	220-240V/50Hz	2000W	60°C - 240°C	855 x 535 x 930mm	302 x 372mm
BIT 02	220-240V/50Hz	2000W+1500W	60°C - 240°C	855 x 535 x 930mm	600 x 388mm

Specifications are subject to change without prior notice



Countertop Induction Deep Fryers

This pioneering product from Butler uses patented technology and is ideal for frying in those places where other forms of heating and cooking are avoidable. No flames or hot surfaces provide for a safer, cooler kitchen. They are a boon for food-courts, airports, railways stations and similar applications.

Key Features

- ♦ Stainless steel body
- ♦ Temperature setting: 60°C, 80°C, 100°C, 120°C, 130°C, 140°C, 150°C, 160°C, 170°C, 180°C, 190°C
- ♦ Touch control



IDF-08 (New), IDF-08

Technical Specifications



Model	Voltage	Power	Temperature Range	Dimensions (wxdxh)	Timer	Frypot Capacity
IDF-08 (New)	220-240V/50Hz	3500W	60°C - 190°C	288 x 478 x 410mm	0-120 mins	8 Ltrs
IDF-08	220-240V/50Hz	3500W	60°C - 190°C	288 x 478 x 410mm	0-120 mins	8 Ltrs

Specifications are subject to change without prior notice

Chafing Dish Warmers

Though not based on induction technology, this is an innovative product from Butler designed to warm traditional metallic chafing dishes thereby allowing warm food to maintain itself at the right temperature whilst improving your presentation and helping you eliminate the use of burners.



InnoWarm



Key Features

- ♦ Keep warm at 90°C
- ♦ Power: 220-240V ~ 50Hz, 500W
- ♦ Dimensions: Ø138mm x 110mm (h)

Induction Cookware

Not all pieces of cookware can be used on induction cooktops. Cookware made from aluminum, copper or glass, including Pyrex will not work on its own. Induction cookware must be made of a magnetic-based material, such as cast iron or magnetic stainless steel. To check if your pans will work, hold a magnet next to the pan base; if it attracts, the pan will work on induction.



The science behind good taste



How to choose the best commercial pizza oven for your business?

Selecting the right pizza oven is essential to starting your pizzeria. From cloud kitchen and large commercial operations to hole-in-the-wall family-owned businesses, what may be appropriate for one setting may not work for a different kind of establishment. Be sure to take the time and research the various pizza oven options available and choose the one that best fits your requirements. Keep in mind the number and size of pizzas you expect to make per day, the fuel source and the space you have for your oven. Also keep in mind which type of oven will bring out the distinctive flavours of your pizza to the fullest. Budget might also be a concern, but try not to skimp on your pizza oven, as it is the very foundation of your pizza business.

Gas vs. Electric Pizza Ovens

Conveyor or deck ovens are all available with either gas or electric hookups. However there are some slight differences between gas pizza ovens and those that run on electric. Working with a gas oven is best for the high-volume, traditional pizza maker. These units will produce a crispier crust and cook the rest of your pizza evenly. But what it all really boils down to is what utility your establishment has available. If your business doesn't have access to natural gas or liquid propane, then the electric models will better suit your needs.

Application

Suggested Oven Type

Expected pizza output

The primary driver of which pizza oven to opt for comes from the pizza output expected by any eatery.



Conveyorised Hot Air Impingement Ovens

Conveyorised Hot Air Impingement Ovens

Stone Deck Ovens

Small Stone Deck Ovens



Multi-Purpose Conveyorised Impingement Ovens

Butler Hot Air Conveyorised Impingement Ovens are designed to cook a variety of products including pizzas, bagels, garlic breads, omelettes, sea food and ethnic Indian foods like naans, crisp rotis, kebabs and more.

What is impingement technology?

Impingement technology uses hot air to be directed at the cooked products from the top and bottom through specially designed "pores" that form columns of air moving the heat aerodynamically at a high speed. This hot air penetrates the surface moisture barrier of the product transferring heat and engulfing the product to retain its moisture.

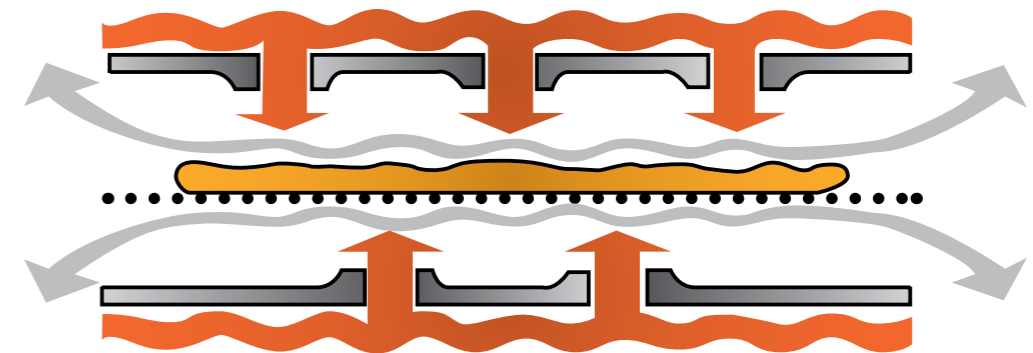

400 mm (15")
belt width

520 mm (20")
belt width

800 mm (30")
belt width



Gusto Conveyorised Hot Air Impingement Ovens

The Butler Gusto Hot Air Conveyor Ovens bake faster and at a lower temperature than other ovens. Hot air moves the heat aerodynamically instead of using high temperatures. The streams of hot air remove the surrounding layers of cool heavy air around the foodstuff. Gusto ovens are designed to cook a wide range of products including pizza, breads, sandwiches, bagels, naans, sea food and more. They offer a premier countertop or a floor standing cooking platform for cloud kitchens, busy pizzerias and restaurants. Available in a choice of electric and gas versions, they utilise a choice of conveyor belt widths from 400 mm to 800mm.



Gusto 800G Max Conveyorised Impingement Ovens

This heavy duty hot air impingement oven from Butler comes with a 800mm wide belt and a 940 mm x 800 mm baking chamber and can bake large pizzas or 3 x 9" pizzas placed side by side. The oven is also designed to cook a variety of other products including bagels, garlic breads, omelettes, sea food and ethnic Indian foods like naans, crisp rotis, kebabs and more.



Gusto 800G Max

Standard Features

- ◆ Available in PNG or LPG model
- ◆ Electricity: 220V, 50/60 HZ, 300 watts
- ◆ Gas consumption: LPG 1.10 m³/h, PNG 2.60 m³/h
- ◆ Conveyor belt width: 800 mm
- ◆ Heating zone (heating chamber) length: 940 mm
- ◆ Oven dimension: 1800 mm x 1570mm x 600mm
- ◆ Net weight of single oven: 396 kg
- ◆ Maximum operating temperature: 300°C (230°C is recommended)
- ◆ Warm up time: 6-8minutes
- ◆ Baking time: 5 – 6 minutes at 230°C



Optional Cleanability

- ◆ Stand with casters
- ◆ Butler Gusto Ovens are designed for easy cleaning. Removable parts include: crumb pans, end panels, air fingers, exit tray, and a removable conveyor belt assembly.

Ventilation

- ◆ Use of a ventilation hood is recommended.

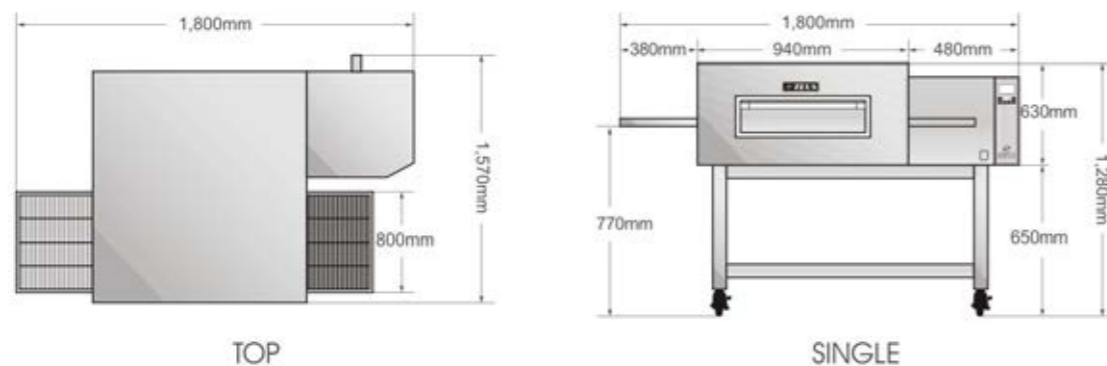

Gusto 520 Conveyorised Impingement Ovens

These heavy duty hot air impingement ovens from Butler come with a 520mm wide belt and a 710 mm x 520 mm baking chamber and can bake large pizzas or 2 x 9" pizzas placed side by side. Available in gas or electric options. These ovens are also designed to cook a variety of other products including bagels, garlic breads, omelettes, sea food and ethnic Indian foods like naans, crisp rotis, kebabs and more.



Gusto 520G
Gusto 520E

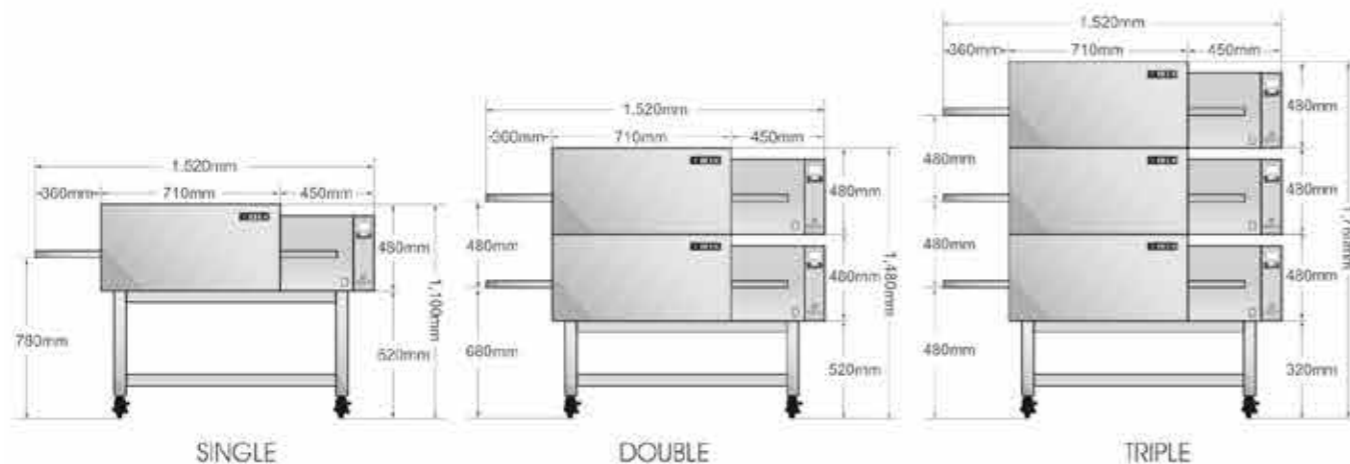

Standard Features

- ◆ Maximum operating temperature: 300°C (230°C is recommended)
- ◆ Short set-up time: (Gas: 6~8 mins under set temp. 230°C; under preheat condition, only 3 minutes. Electric: 10~20 / 5-7 minutes)
- ◆ Reduced gas consumption and increased cooking efficiency
- ◆ Low noise
- ◆ 28" (710mm) long cooking chamber with 20.5" (520 mm) belt
- ◆ 57" (1445mm) long, 39" (1000mm) deep, and 19" (480mm) high overall dimensions
- ◆ Furnished with 4" legs
- ◆ Stackable up to three high
- ◆ Microprocessor-controlled bake time/conveyor speed
- ◆ Stainless steel front, sides, top and interior
- ◆ Reversible conveyor direction
- ◆ Energy saving standby mode (gas)
- ◆ 2 conveyor end stops
- ◆ 2 crumb pans

Optional Cleanability

- ◆ Stand with casters
- ◆ Butler Gusto Ovens are designed for easy cleaning. Removable parts include: crumb pans, end panels, air fingers, exit tray, and a removable conveyor belt assembly.

Ventilation

- ◆ Use of a ventilation hood is recommended.

Gusto 400E

The Countertop Impingers

This countertop impinger from Butler comes with a 400mm wide belt and a 460 mm x 400 mm baking chamber and can bake upto 15" pizzas. The oven can be made to run either on 240V/ single phase or 380V/3 phase electricals. The oven is also designed to cook a variety of other products including bagels, garlic breads, omelettes, sea food and ethnic Indian foods like naans, crisp rotis, kebabs and more.



Gusto 400E



Standard Features

- ◆ Maximum operating temperature: 300°C (230°C is recommended)
- ◆ Short set-up time: (10-12 mins to set temp. 230°C) under preheat condition, only 5-7 mins
- ◆ Low noise
- ◆ 460 mm long cooking chamber with 400 mm belt
- ◆ 1065mm long, 850mm deep, and 450mm high overall dimensions
- ◆ Furnished with 4" legs
- ◆ Stackable up to three high
- ◆ Microprocessor-controlled bake time/conveyor speed
- ◆ Stainless steel front, sides, top and interior
- ◆ Reversible conveyor direction
- ◆ Energy saving standby mode
- ◆ 2 conveyor end stops
- ◆ 2 crumb pans

Optional Cleanability

- ◆ Stand with casters
- ◆ Butler Gusto Ovens are designed for easy cleaning. Removable parts include: crumb pans, end panels, air fingers, exit tray, and a removable conveyor belt assembly.

Ventilation

- ◆ Use of a ventilation hood is recommended.

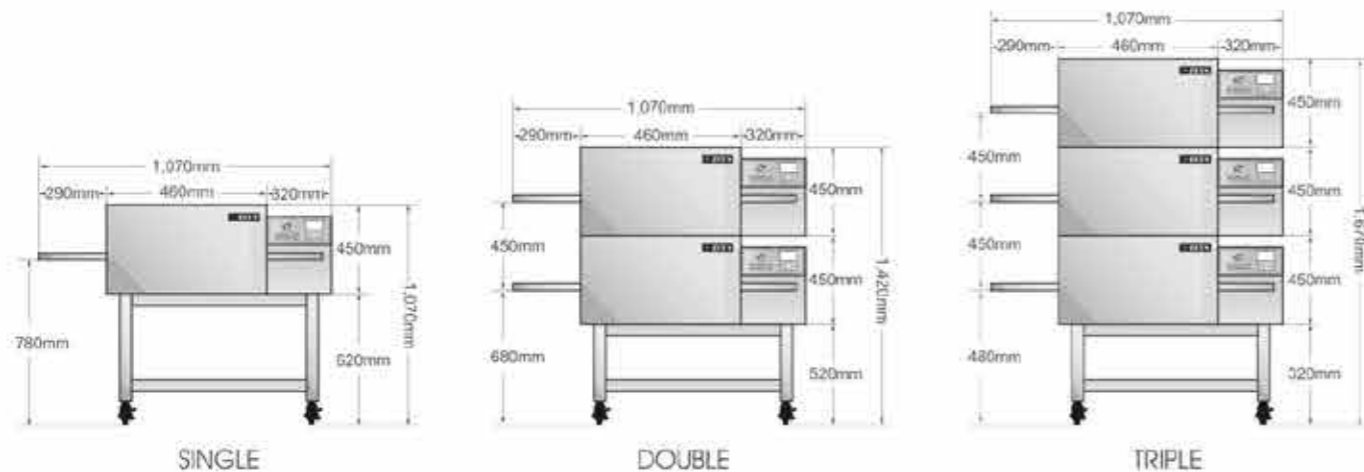



Technical Specifications - Gusto Hot Air Conveyor Pizza Ovens

Model	Gas	Input Electricity	Gas Pressure (kpa)	Gas Consumpton (m ³ /hr)	Dimension L*W*H (MM)	Volume (M ³)	Conveyor size (MM)	Calorie (Kcal/h)	Baking Chamber Dimensions (MM)	Output pcs (9" pizza)	Net weight (KG)
GUSTO 800G Max	LPG	220V 50/60Hz	2.3-3.3	1.10 m ³ /h	1800 x 1570 x 600	1.64	1700*800	26000	910 x 800	180/hr	396
	PNG		1.0-2.5	2.60 m ³ /h							
GUSTO 520G	LPG	220V 50/60Hz	2.3-3.3	0.42 m ³ /h	1520*1140*480	0.83	1445*520	10000	710 x 520	70/hr	146
	PNG		1.0-2.5	0.95 m ³ /h							



Model	Input Electricity	Electric Power Output (KW)	Power Consumpton (KWH)	Dimension L*W*H (MM)	Volume (M ³)	Conveyor size (MM)	Calorie (Kcal/h)	Baking Chamber Dimensions (MM)	Output pcs (9" pizza)	Net weight (KG)
GUSTO 520E	380V/50Hz/3Ph	11.5	7.5	1520*1140*480	0.83	1445*520	10000	710 x 520	70/hr	146
GUSTO 400E	220V/50Hz/1Ph*	6.8	4.0	1065*850*450	0.39	1055*400	7300	460 x 400	20/hr	106

Maximum operating temperature: 300°C (230°C is recommended)

Specifications are subject to change without prior notice due to continuous product development

*Same oven can also be made to operate on 380V/50Hz/3Ph



Pizza Stone Ovens - Premia Series

Butler Premia Series Pizza Stone Ovens are designed to churn out great tasting pizzas with amazing consistency. The pizza stone changes the game by acting as a point high heat transfer. The stone heats up and holds very high temperatures. When the pizza is placed on the stone, the crust begins to cook immediately, mimicking the cooking style of a traditional brick oven. You can choose between electric models (EPO series) or gas operated model (GPO series).

- ◆ All stainless steel body
- ◆ High quality pizza stone accommodates upto 6 pizzas of 8" size (EPO-36 Premia DT & GPO-36 Premia only)
- ◆ Digital temperature control with timer allows users to set any constant temperature/time
- ◆ A peep-in window offers a view of the pizzas while being baked
- ◆ Insulated chamber



EPO-36 Premia DT, GPO-36 Premia

Pizza Stone Ovens with Touch Control

Butler Touch Control Pizza Stone Ovens are designed to churn out great tasting pizzas with amazing consistency. The pizza stone changes the game by acting as a point high heat transfer. The stone heats up and holds very high temperatures. When the pizza is placed on the stone, the crust begins to cook immediately, mimicking the cooking style of a traditional brick oven. You can choose between electric models (EPO series) or gas operated model (GPO series).

- ◆ All stainless steel body
- ◆ High quality pizza stone accommodates upto 6 pizzas of 8" size (EPO-36 Touch & GPO-36 Touch only)
- ◆ Digital temperature control with timer allows users to set any constant temperature/time
- ◆ A peep-in window offers a view of the pizzas while being baked
- ◆ Insulated chamber



EPO-36 Touch, GPO-36 Touch

Technical Specifications



Model	Power	Electricals	Temperature Range	Dimensions WxDxH (mm)	Stone Dimension WxDxH (mm)	Cavity Dimension WxDxH (mm)	Weight
EPO-36 Premia DT	3.2kW	220V/50Hz	20-400°C	925x570x430	645x480x15	640x470x180	38.5kg
GPO-36 Premia*	48W	220V/50Hz	20-400°C	1000x750x550	620x520x15	650x570x180	68kg
EPO-36 Touch	3.2kW	220V/50Hz	20-400°C	925x570x430	645x480x15	640x470x180	38.5kg
GPO-36 Touch*	48W	220V/50Hz	20-400°C	1000x750x550	620x520x15	650x570x180	68kg

*Gas Consumption: 0.24kg/hr

Specifications are subject to change without prior notice due to continuous product development

Mini Pizza Stone Ovens

Butler's Mini Pizza Stone Ovens are designed to churn out great tasting pizzas with amazing consistency. The pizza stone heats up and holds high temperatures. When the pizza is placed on the stone, the crust begins to cook immediately, much like the cooking style of a traditional brick oven. You can choose between two electrically operated models - one with a single deck and the other with 2 decks.

- ♦ All stainless steel body
- ♦ High quality pizza stone
- ♦ Simple temperature control allows users to set a constant temperature
- ♦ A peep-in window offers a view of the pizzas while being baked
- ♦ Temperature range from 0 - 350 degree C
- ♦ Insulated chamber



EPO-1D



EPO-2D

Model	Power	Electricals	Temperature Range	Dimensions W x D x H (mm)	Stone Dimension W x D x H (mm)	Cavity Dimension W x D x H (mm)	Weight
EPO-1D	2kW	220 - 240V/50Hz	0-350°C	560x570x280	400x400x15	410x410x120	24kg
EPO-2D	3kW	220 - 240V/50Hz	0-350°C	560x570x440	400x400x15	410x410x120	33kg

Specifications are subject to change without prior notice due to continuous product development *Gas Consumption (GPO-36 Premia): 0.24 KG/h

Electric Griddle Plates

These steel fry tops from Butler are ideal for cooking dosas, chillas, paratha, meat, bacon, fish, sausages, fried eggs, omelettes and a wide variety of Indian style tawa preparations.

- ♦ Homogenous cooking
- ♦ Heavy duty heating element
- ♦ Temperature Control
- ♦ Easy to clean



EGP-550



EGP-730FG



Model	Power	Temperature Range	External Dimensions W x D x H (mm)	Griddle Dimensions W x D x H (mm)
EGP-550	3kW	50°C-320°C	550x450x230	548x348x10
EGP-730FG	4.4kW	50°C-300°C	730x530x260	728x396x10 2/3rd Plain, 1/3rd Grooved

Voltage: 220-240V/50Hz development

Specifications are subject to change without prior notice due to continuous product development



Commercial Microwave Ovens

The Butler commercial microwave ovens are a perfect replacement for inappropriate domestic ovens used in food-service applications. They bake fast and evenly and are suitable for a wide variety ranging from pastries to entrees. The durable construction is perfectly adapted for commercial usage such as cafés, food stores, pizza outlets, casual dining restaurants, clubs, deli applications and more.



MWO-34HD

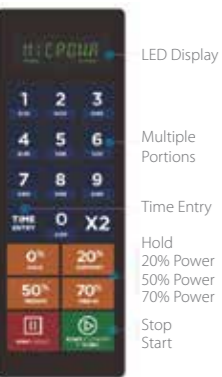

- ◆ 34 litre capacity accommodate 16" platters
- ◆ Up to 100 programmable menu options for consistent results
- ◆ User friendly touch control pad
- ◆ 3 stage cooking and 5 microwave power levels
- ◆ See-through door with lighted interior
- ◆ Grab'n Go handle
- ◆ Stainless steel cabinet and oven cavity
- ◆ Removable splatter shield
- ◆ Stackable installation



MWO-25

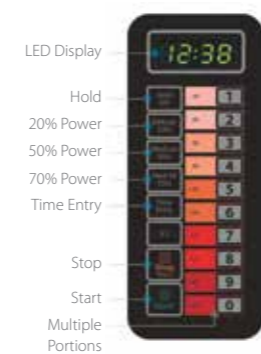

- ◆ 25 litre capacity accommodates 12" platter
- ◆ Up to 20 programmable menu options for consistent results
- ◆ User friendly touch control pad
- ◆ 3 stage cooking and 5 microwave power levels
- ◆ See-through door with lighted interior
- ◆ Grab'n Go handle
- ◆ Stainless steel cabinet and oven cavity
- ◆ Removable splatter shield

Difference between commercial and household microwave ovens

Commercial Microwave Ovens

Conventional Microwave Ovens

Functions	Commercial Microwave Ovens	Conventional Microwave Ovens
	<ul style="list-style-type: none"> ◆ Even heat delivery to the food, large capacity, pre-set memory, one button for common menus ◆ Three power levels and automatic fault diagnosis 	<ul style="list-style-type: none"> ◆ Slow heating, unsuitable for commercial applications, rely on turntable for even heating ◆ No automatic fault diagnosis
Durability	<ul style="list-style-type: none"> ◆ Stainless steel cavity ◆ Withstands frequent usage (100s of times per day) 	<ul style="list-style-type: none"> ◆ Sprayed or painted doors ◆ Only for home use (3-5 times per day)
Cleaning	<ul style="list-style-type: none"> ◆ Smooth internal and external design, easy to clean 	<ul style="list-style-type: none"> ◆ Turntable structure leads to accumulation of residues, difficult to clean
Capability	<ul style="list-style-type: none"> ◆ Heating not compromised by large capacity 	<ul style="list-style-type: none"> ◆ Can accommodate limited amount of food

Model	External Dimensions W x D x H (mm)	Cavity Dimensions W x D x H (mm)	Cavity Volume (Litres)	Input Power (W)	Output Power (W)	Cooking Time (min:sec)
MWO-25	511x311x432	327x200x346	25	1550	1000	3:10
MWO-34HD	553x488x343	370x385x230	34	1900	1400	2:30

*Throughput reflects one piece of Pizza

Specifications are subject to change without prior notice due to continuous product development

Floor Standing Fryers

These American style floor standing fryers from Butler come in two variants - electric and gas and are ideal for quickly frying chicken, fish, french fries, onion rings and more. The gas based Wonderfry - 3BG (FGF-300) comes with 3 tubes and Wonderfry-4BG (FGF-400) is designed with 4 tubes. They come with a single tank and two baskets. The Wonderfry - 16.2E (FEF-16.2) is an electric fryer with 2 baskets & 2 x 16 litre. The fryer tanks are tested for leakage to ensure safety.

- ◆ Thermo-tube design
- ◆ Stainless steel frypot, front door/s, and back splash
- ◆ Wire form basket hanger and 2 fry baskets in both models
- ◆ Adjustable steel legs



Wonderfry - 3BG (FGF-300),
Wonderfry - 4BG (FGF-400)



Wonderfry - 16.2E (FEF-16.2)



Model	Voltage	Power	Gas Input Capacity	No. of Tanks	Each Tank Size	No. of Baskets	Dimensions (wxdxh)	Frybasket Dimensions (wxdxh)
WONDERFRY - 3BG (FGF-300)	220V/50Hz	-	90,000 Btu/hr	1	18-20.5 Litres	2	394x760x885 mm	170x335x280 mm
WONDERFRY - 4BG (FGF-400)	220V/50Hz	-	120,000 Btu/hr	1	22-25 Litres	2	394x760x885 mm	170x335x280 mm
WONDERFRY - 16.2E (FEF-16.2)	380V/50Hz	5 + 5KW	-	2	16 + 16 Litres	2	740x550x910 mm	230x250x120 mm

Specifications are subject to change without prior notice due to continuous product development

Oil Filtration Cart

Butler Oil Filtration Carts are designed for mobile filtering for all your frying appliances. These portable mobile filters have the ability to receive oil gravity drained from fryers and come with 4 castors, a crumbs collection basket and a pump.

Key Features:

- ◆ Four swivel casters allow for easy movement and storage of the filter.
- ◆ Quick disconnect hose connections make it easy to assemble and disassemble.
- ◆ Low profile allows for easy placement under the fryer drain.
- ◆ Easy to remove filter assembly.
- ◆ Lift out filter pan for easy cleaning.



OFC-1

Technical Specifications

Model	Voltage	Power	Tank Capacity	Pumps per minute	Dimensions (wxdxh)	Tank Height	Hose with Nozzle	Castors
OFC-1	220V/50Hz	550W	50L	15 L	440x755x620 mm	235 mm	5 Feet	4

Specifications are subject to change without prior notice due to continuous product development

Countertop Fryers

These professional fryers from Butler are particularly suited for fast food restaurants. Suitable for frying chips, chicken, fish, onion rings in quick succession using minimal quantities oil. The model EF-8 Premia comes with computerised touch controls

- ◆ Precise bulb thermostat in stainless steel
- ◆ Heat resistant handles in baskets
- ◆ Removable parts for ease of cleaning
- ◆ 4 different models to choose from



EF-4, EF-6, EF-8



EF-8 Premia

Model	Power	Capacity	No. of Baskets	Dimensions (W x D x H in mm)	Voltage
EF-4	2 kW	4	1	220x390x370	220V/50Hz
EF-6	2.5 kW	6	1	260x410x285	220V/50Hz
EF-8	3.25 kW	8	1	260x410x340	220V/50Hz
EF-8 Premia	2.5 kW	8	1	280x430x310	220V/50Hz

Specifications are subject to change without prior notice due to continuous product development



Contact Grills - Grooved

The Butler Euro Grill is an electric contact grill that comes in two variants both with grooved top and bottom plates. These models are designed leave grill marks and cook perfect jumbo sized sandwiches, paninis, steaks or hamburgers retaining all juices and vitamins or grill fish, eggplant or similar foodstuff.

- ◆ Cast iron plates for even cooking
- ◆ Self-balanced upper plate
- ◆ Euro Grill Premia/PG-11E Premia model comes with the Timer and Touch Control Screen
- ◆ Euro Grill/PG-11E model comes with simple to use, electromechanical controls



Euro Grill (PG-11E)

Euro Grill Premia (PG-11E Premia)



Model	Power	Temperature Range	Dimensions W x D x H (mm)	Cooking Surface (mm)	Net Weight
Euro Grill (PG-11E)	2.8 Kw	50°C-300°C	430x310x200	340 x 230	25 Kg
Euro Grill Premia (PG-11E Premia)	2.8 Kw	50°C-300°C	425x400x210	340 x 230	21 Kg

Electricals : 220 V Specifications are subject to change without prior notice due to continuous product development

Contact Grills - Flat

The Butler Indo Grill Premia/ FPG-11E Premia an electric contact grill is specially designed with flat top & bottom plates and are suitable for cooking or regenerating paranthas, chillas, mini uttapams, mini dosas, wraps, steaks or similar foodstuff that does not require grill marks. The advantage of this model is that it is easy to clean.

- ◆ Timer and Touch Control Screen
- ◆ Cast iron plates for even cooking
- ◆ Self-balanced upper plate



Indo Grill Premia (FPG-11E Premia)



Model	Power	Temperature Range	Dimensions W x D x H (mm)	Cooking Surface (mm)	Net Weight
Indo Grill Premia (FPG-11E Premia)	2.8 Kw	50°C-300°C	425x400x210	340 x 230	21 Kg

Electricals : 220 V Specifications are subject to change without prior notice due to continuous product development

Rotary Waffle Bakers

The rotary waffle bakers from Butler come with a electro-mechanical timer and can accept deep-frozen, frozen pre-cooked waffles or freshly made batter for making golden crispy waffles.

- ◆ Quick and even heat spread
- ◆ Temperature control range: 124°C ~ 230°C
- ◆ Time Control Range: 99 Minutes & 50 Seconds ~00 Minutes & 00 Seconds
- ◆ The baking plate can revolve 180° baking evenly across both the plates



RWB-04



Model	Power	Weight	Temperature Range	Baking Plate Revolve	Dimensions (W x D x H in mm)	Time Control Range
RWB-04	2kW	10kg	124°C ~ 230°C	180°	310x380x285	50Sec ~ 99Mins

Voltage: 220-240V/50Hz Specifications are subject to change without prior notice due to continuous product development

Crepe Makers

High quality crepe machines for delicious, moist, golden pancakes, buckwheat cakes, Indian tempura, sweet chillas and the like. The cast iron plate is perfectly smooth and facilitates a direct heat transfer. A slight degreasing of the pancake or crepe would ensure a honeycombed, golden crepe with no caramelization or glazing.

- Even cooking with minimal use of oil
- Ideal for outdoor or kiosk use



Model	Power	Temperature Range	Dimensions (W x D x H in mm)
CM-01	3 KW	50°C-300°C	450x485x235

Electricals : 220 V Specifications are subject to change without prior notice due to continuous product development

Electric Bain Mairies

Butler Bain-Mairies come in a GN 1/1 compatible size and can be easily paired together due to their modular and multi-plexable design to create an excellent food warming option to suit the needs of busy catering environments. They come with 2 x GN 1/2 containers with lids.



Model	Power	Dimensions W x D x H (mm)	Temperature Range
BM-1/1	1.8kW	340x560x280	30°C -85°C

Voltage: 220-240V/50Hz Specifications are subject to change without prior notice due to continuous product development

Electric Salamanders

Butler salamanders can be used to defrost, brown, grill toasts, gratins, pizzas, onion soups etc. without preheating.

- High quality cooking
- Easy to clean



Model	Power	Temperature Range	Dimensions (W x D x H in mm)
ES-610	1.82~2 kW	50°C-300°C	610x340x280

Electricals : 220 V Specifications are subject to change without prior notice due to continuous product development

Cone Bakers

Be distinct. Make your own ice cream cones. Expand your menu with these compact and reliable countertop units from Butler that serve up hot, crisp, delicious waffles and waffle cones in just minutes. Butler Cone Baker preheats to ideal temperature in minutes and provides up to 60 cones per hour. Don't forget the whipped cream, sprinkles, and a bowl of cherries to top off the sundaes. And watch your sales soar!

Model	Power	Temperature Range	Dimensions (W x D x H in mm)
CB-01	1.2 KW	50°C-300°C	280x400x290

Electricals : 220 V Specifications are subject to change without prior notice due to continuous product development



Delivered with a mould for making ice cream cones



Gelato Panini Grill

'Ice on Fire' from Butler is a new, exciting concept in the frozen dessert business that allows you to add an interesting dimension to your menu. This easy-to-use Panini Grill turns gelato, soft serve, ice cream, or frozen yogurt into a creamy delight sealed in a golden-toasted bun. Garnished or mixed with a savory or sweet topping, scrumptious Gelato Panini can be served sliced on a plate or as a full sandwich in an on-the-go wrapper. Warm on the outside, and cold on the inside, this novel treat is sure to light up your business.



Cut bun in half and add gelato, ice cream or frozen yogurt



Seal it with the other half of the bun and place in the cavity, press and cook



Cut the creamy burger into 2 or more pieces and serve



Ice of Fire



Technical Specifications

Model	Power	Electricals	Dimensions (WxDxH) mm
Ice on Fire	1300W	220V/50Hz	380x260x380

Specifications are subject to change without prior notice





Electric Rice Steamers

The Butler Steam Master is a versatile equipment that can steam a wide variety of items including rice, corn, idlis, dhoklas, momos, potatoes, vegetables, eggs, fish, chicken and more. It is way more cost effective an appliance as compared to combi steamers when the requirement is essentially steaming. Made in high quality stainless steel it is also energy efficient and comes with several safety features viz., door locking system, dry fire protection and an auto water feeding float ball.



Approximate Cook Time

- ◆ Seafood 15 minutes
- ◆ Meat(chicken) 35 minutes
- ◆ Bun 40 minutes
- ◆ Rice 45 minutes
- ◆ Stew 60 minutes



Rice Master

Model	Voltage	Power	Dimensions W x D x H (mm)	Input Steam Pressure	No. of Trays	Tray Size	Tray Material	Rice weight per tray	Rice steaming time	Weight
Rice Master	380V/50Hz	9.0KW	700*600*1070	0.02Mpa	6	600*400mm	SS 304	Max 3.5 kgs	Approx. 40 minutes	50 KG

Specifications are subject to change without prior notice due to continuous product development



CT-300



Conveyor Toasters

Butler conveyor toaster is designed to toast bread and buns fast - over 300 slices per hour. It works on belt speed and not temperature, to determine the colour of toasting.

- ◆ Robust, stainless steel construction
- ◆ Easy to load guide rack
- ◆ Adjustable speed belt
- ◆ Flexibility to choose front or rear discharge
- ◆ Easy to clean and removable trays

Model	Power	Dimensions W x D x H (mm)	Chamber Dimensions W x D x H (mm)	Temperature Range	Heating Elements	Fans
CT-300	2.67kW	595x530x570	460x375x360	50°C - 300°C	2	2

Voltage: 220-240V/50Hz

Specifications are subject to change without prior notice due to continuous product development

Pop-up Toasters

The 6 slot pop-up toaster from Butler is built to suit the heavy duty needs of busy kitchens and restaurants. It comes with a bottom crumb tray for bread particles.

- ◆ 6 slot toaster
- ◆ Stainless Steel construction
- ◆ Rounded edge design
- ◆ 5 minute timer



POP-06

Model	Power	Electricals	Dimensions (W x D x H in mm)
POP-06	3.24 KW	220V / 50Hz	460x210x225

Specifications are subject to change without prior notice due to continuous product development

Pass Through Bun Toaster

Butler's Bun Toasters come in a choice of two options - Pass Through Type (model PT-BT) and Batch Type (model BT-05). They are a great choice for toasting buns for burgers and sandwiches. They are designed to deliver higher toasting capacities. A strong motor and higher temperature platen increase performance, that caramelizes the bread and prevents it from getting soggy from the juices and condiments. Adjustable bun crush controls and thermostat allow for precise toasting for various bread products.



PT-BT



BT-05

Model	Power	Weight	Dimensions (W x D x H)	Electricals
BT-05	2000 ~ 2400W	-	410x700x300 mm	220V / 50 Hz/1Ph
PT-BT	1600W	26 kgs.	420x250x585 mm	220V / 50 Hz/1Ph

Specifications are subject to change without prior notice due to continuous product development

Patties Warmer

Butler's latest innovation holds more than just burgers and patties. With optimal hold times and unique zone temperature controls, operators can now increase menu and recipe variety while maintaining food quality and safety.

- ◆ C/F can be freely switched.
- ◆ Wide temp range can be adjusted from 30-90°C
- ◆ Timing accurately and long from 0-100 hours
- ◆ Reminder function when working time is over
- ◆ Digital control with digital display
- ◆ Using heating film, heat food uniformly and fast.
- ◆ Save energy consumption
- ◆ Independent thermostat each layer
- ◆ Automatic heating
- ◆ Heat dissipation fan
- ◆ ATC heating film



RTR-520L-1



RTR-520L

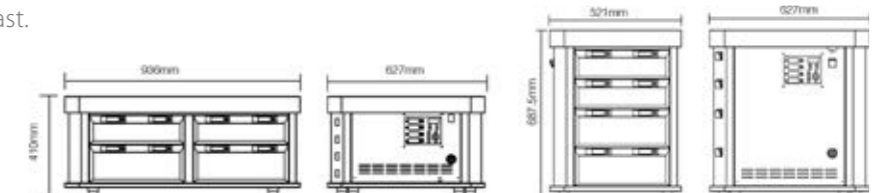

Model	RTR-520L-1	RTR-520L
Capacity-Gross	Four heating channels	Four heating channels
Temperature range	30-100°C (86-212°F)	30-100°C (86-212°F)
Rated Input Power	3000W	3000W
N.W.	82.5kg(181.9lbs)	78.5kg(173.1lbs)
G.W.	100kg(220.5lbs)	90kg(198.4lbs)
Dimensions (WxDxH)	936x627x410mm	627x521x687.5mm

Specifications are subject to change without prior notice due to continuous product development



High temperature resistant pan

Flat Packed Stainless Steel Furniture

The knocked down stainless steel furniture range from Butler perfectly complements its cooking and food preparation equipment. Built in solid 0.8mm stainless steel, it is easy to install and aims to comprehensively address the equipment needs of commercial kitchens.



Work Tables with Splash Back

- ◆ Flat packed
- ◆ Easy to install
- ◆ Four side table support for stability

Model	Description	Dimensions (WXDXH) mm
WT.1200SB	Work Table with Splash Back - 1200 mm	1200*700*850+100

Work Tables

- ◆ Flat packed
- ◆ Easy to install
- ◆ Four side table support for stability

Model	Description	Dimensions (WXDXH) mm
WT.1200	Work Table - 1200 mm	1200*700*850



Stands with 4 shelves

- ◆ Flat packed
- ◆ Easy to install
- ◆ Holes for air ventilation
- ◆ Each shelf designed to accommodate a load 80 kg



Model	Description	Dimensions (WXDXH) mm
4S.1000	Stand with 4 shelves - 1000mm	1000*500*1800
4S.1200	Stand with 4 shelves - 1200mm	1200*500*1800
4S.1400	Stand with 4 shelves - 1400mm	1400*500*1800
4S.1500	Stand with 4 shelves - 1500mm	1500*500*1800
4S.1800	Stand with 4 shelves - 1800mm	1800*500*1800

Single Layer Wall Shelves

- ◆ Flat packed
- ◆ Easy to install
- ◆ Adjustable shelf height

Model	Description	Dimensions (WXDXH) mm
1S.1000	Single Layer Wall Shelf -1000mm	1000*300*600
1S.1200	Single Layer Wall Shelf -1200mm	1200*300*600



Food preparation made easy





CE

Vegetable Preparation Machines

The VPM-65 is a compact vegetable preparation machine from Butler for heavy duty usage. It comes with a powerful, yet low noise motor designed to perform the varied functions ranging from slicing, grating, dicing and julienne effortlessly.

- Delivered with metal bowl and lid; removable lid equipped with two hoppers – small and large
- Includes 7 discs for french fries, slicing and shredding.

Model	Power	Dimensions W x D x H (mm)	Disc diameter	Net Weight
VPM-65	750W	650 x 325 x 535	204 mm	25 kgs

Voltage: 220-240V/50Hz Specifications are subject to change without prior notice due to continuous product development



VPM-65



For french fries



For slicing



For shredding

Potato Peelers

Butler Potato Peelers are made in a stainless steel body and are easy to operate, maintain and clean. They lend a remarkable efficiency to the otherwise tedious potato peeling process in restaurant kitchens, canteens and hotels. They come with a water inlet pipe, stainless peeling disc and high efficiency ventilated motors for continuous operation.



Model	Power	Dimensions W x D x H (mm)	Production capacity	RPM	Net Weight
PP-15A	750W	475 x 540 x 785	15Kg/hr	227	94 kgs

Voltage: 220-240V/50Hz Specifications are subject to change without prior notice due to continuous product development



PP-15A

Meat Slicers

These semi-automatic meat slicers from Butler come with high quality bearing design that allows for a smooth operation. The handle is safe and convenient to use when in operation. They are easy to clean, are durable and have a firm-grip base.

Model	Power	Dimensions W x D x H (mm)	Blade diameter	Cutting thickness	Net Weight
SL 250 ES-10	320W	390 x 470 x 380	250mm/10"	0~10 mm	15.5 kgs

Voltage: 220-240V/50Hz Specifications are subject to change without prior notice due to continuous product development



SL 250 ES-10, SL 300 ES-12



TC-8, TC-12



Meat Mincers

These durable meat mincers from Butler come with an all stainless steel construction. They are easy to operate & clean; conform to international sanitation standards. All models are loaded with an easy to replace, circular orifice knife and cross-blades.

Model	Power	Dimensions W x D x H (mm)	Capacity	Net Weight
TC-8	350W	370 x 230 x 470	80 kgs /h	20 kgs

Voltage: 220-240V/50Hz Specifications are subject to change without prior notice due to continuous product development

Bone Saw Machines

The Bone Saws from Butler are designed to cut bones, frozen meat, fish etc., and are easy to operate & clean. J-210 is a countertop model that uses high quality stainless steel saw blades to ensure smooth cutting. So is the working table and parts that come in touch with the food which confirms to international sanitation standards. It comes with a built-in waterproof safety device that automatically stops the machine if the outer cover is open.



J-210

Model	Power	Dimensions WxDxH (mm)	Working Table Size WxDxH (mm)	Blade Size WxDxH (mm)	Rotational Speed	Cutting Height	Cutting Thickness	Net weight
J-210	650W	520x470x820	500x380	1650x16x0.5	1420 RPM	0~180mm	5~155mm	40Kg

Voltage: 220-240V/50Hz Specifications are subject to change without prior notice due to continuous product development



Four stainless steel stuffing funnel sizes (16, 22, 30, and 38mm)



TV-7L

Sausage Fillers

These vertical Sausage Fillers from Butler are designed to be used in restaurant kitchens and for food processing and are easy to operate & clean. The body is made in stainless steel and conforms to international sanitation standards. Strong gear and a double-thick stuffing rack, makes them powerful and durable. They come with two speed regulations for increased efficiency and convenience.

Model	Dimensions W x D x H (mm)	Capacity	Net Weight
TV-7L	850 x 320 x 290	7L	16 kgs

Voltage: 220-240V/50Hz Specifications are subject to change without prior notice

Hamburger Patty Press

The Butler Manual Hamburger Patty Press has a simple, functional design. It is designed to be used in restaurant kitchens and for food processing. The whole body is made of aluminium and the patty bowl is made in stainless steel confirming to international sanitation standards. The platform is firm and durable making the patty press easy to operate and clean.

Model	Patty Diameter	Dimensions W x D x H (mm)	Net Weight
SL-H100	110mm	230 x 165 x 280	4.6 kgs

Voltage: 220-240V/50Hz Specifications are subject to change without prior notice due to continuous product development



SL-H100

Bowl Cutters

The Bowl Cutters from Butler are designed to cut and chop fresh meat as well as vegetables into pieces within minutes, whilst allowing them to retain their nutrition and taste. The blade and 6 litre food bowl are made in high quality stainless steel that conforms to international sanitation standards. The food plate is easy to remove, clean and install. The high speed, S shaped blade enhances efficiency and saves labour and time. The machine is designed to stop when the bowl cover is open. It has overload and overheat protection for increased safety and a waterproof level of IPX4.



SL-400

Model	Power	Dimensions W x D x H (mm)	Blade Rotational Speed	Plate Rotational Speed	Plate Diameter	Net Weight
SL-400	400W	670x480x410	1460 RPM	20 RPM	400mm	36 kgs

Voltage: 220-240V/50Hz Specifications are subject to change without prior notice due to continuous product development

Table Top Vacuum Packing Machine

Vacuum packing is a method of packaging that removes air from the package prior to sealing. ... On a more short-term basis, vacuum packing can also be used to store fresh foods, such as vegetables, meats, and liquids, because it inhibits bacterial growth. Vacuum packing greatly reduces the bulk of non-food items.

The Butler vacuum packing machine facilitates the extension of the shelf life of raw or cooked foods, without weight loss, without drying out or mixing of flavours and odours. It perfectly packages products in vacuum bags and practical reusable containers, inside or outside the vacuum chamber. The transparent tempered glass lid provides better visibility of the product during packaging.



DZ 400T



Model	Electricals	Power	Sealing length	Sealing Width	Thickness	Chamber Dimensions	Dimensions DxWxH (mm)	Weight
DZ 400T	220V/50Hz	0.9KW	400mm	10mm	0.1-0.5mm	440x420x75mm	550x640x600mm	75kg

Specifications are subject to change without prior notice due to continuous product development

Adopt hygiene standards
that make you stand out



More and more hotels, restaurants, banquet halls, canteens, reception areas and offices are now proactively looking for technology driven solutions to keep their staff and guests safe. Butler is happy to present a bouquet of cutting edge products that address the pain points such as sterilisation of tableware, enhancement of personal hygiene, hands free water dispensing and sanitisation of fruits & vegetables. Products that will help you stand out by giving your customers and staff the requisite assurance of safety and hygiene.

General Hygiene

Restaurants, hotels, clubs, salons and business lounges are now ready for exploring technological interventions that may enhance guest hygiene perceptibly at all the touch points with their guests.

UV Multipurpose Sterilisers

Butler UV Multipurpose Steriliser is a versatile product that can sterilise a vast variety of items ranging from knives, cutlery, small packages, currency notes, masks and also treat wet towels with UV light and high temperature that ensures healthier, cleaner and disinfected towels for your customers. Ideal for restaurants, salons, business lounges, meeting rooms, reception areas and other health care applications. When using the hand towel sterilisation, you can also use the hot air circulation feature.



UVS-20



Sterilisation & Warming of Hand Towels



Sterilisation of Knives



Sterilisation of Currency Notes



Disinfection of Small Packages

Key Features:

- ◆ Use of UV & high temperature ensures comprehensive cleaning, warming and disinfection
- ◆ Independent control for UV and warming function allows it to disinfect a vast variety of items
- ◆ Holds up to 70 facial/hand towels; also suitable for knives, cutlery, small packages, currency notes and masks
- ◆ UV sanitising function kills up to 99.9% of bacteria
- ◆ Equipped with water tray and interior towel rack
- ◆ Warms towels up to 75 degree C
- ◆ Sterilisation time: 25 minutes
- ◆ The UV light automatically switches off when the door is opened



Technical Specifications

Model	Dimensions (mm)			Electricals	Frequency (Hz)	Power (W)		Temperatures (°C)	Capacity (L)	Weight (Kg)
	W	D	H			Heating	Sterilization			
UVS-20	450	285	330	220V	50/60	180	6	75°C ± 10°C	20	7.5

Specifications are subject to change without prior notice due to continuous product development

Foot Press Water Dispensers

Supermarkets, offices and commercial organisations are beginning to explore how they can avoid multiple contacts to surfaces that are often used. One such product is a bottled water dispenser. You can now experience, hygiene, style and convenience, all in one smart package with the 'hands free' water dispensers from Trufrost. Ideal for supermarkets, offices, showrooms, restaurants, reception areas and more, you get pure water either hot, cold or at ambient temperature dispensed at the press of your foot.

Key Features:

- ◆ Hot, cold and ambient water options
- ◆ Foot operated mechanism ensures hygiene
- ◆ LED indicators
- ◆ Compact design
- ◆ CFC free refrigerant



FP-BWD



Technical Specifications



Model	FP-BWD
Cooling Method	Compressor
Cooling Capacity	3 L/Hr. >15°C
Cooling Tank Capacity	3.2L
Cooling System Wattage	86W
Heating Capacity	5 L/Hr (85-90°C)
Hot Tank Capacity	1.0L
Heating System Wattage	500W
Dimensions WxDxH (mm)	347 x 370 x 1045
Net Weight	16Kg
Electricals	220V / 50Hz / 1Ph

Based on standard test conditions

Specifications are subject to change without prior notice due to continuous product development
Suitable for standard polycarbonate jars/bottles (not supplied with dispensers).

Cooling
without compromise



Trufrost brings to India a comprehensive range of reliable biomedical refrigeration products that are suitable for hospitals, blood banks, pharmacies, research institutes, laboratories in electronic & chemical plants, fisheries and more.

-150°C Cryogenic Freezers

This product is specially designed and manufactured for long term storage of various biological products, including viruses, germs, erythrocytes, leucocyte and cutis. Applications can be found in blood banks, hospitals, epidemic prevention services, and research institutes, laboratories in electronic and chemical plants, bio-logical engineering institutes and marine fishery companies.



MDF-150H128

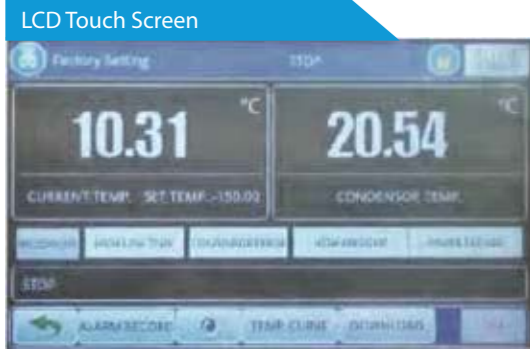

Safety

- ◆ Malfunction alarms including high and low temperature, power failure, sensor error, clean-filter, and condenser clean, abnormal voltage, low battery, thermostate failure
- ◆ Capable of producing two types of alarm outputs, audible buzzer and visible flashing light.
- ◆ Door open feature standard and USB port for temperature data downloading standard on upright models.
- ◆ Remote alarm contacts.

Installation and application

- ◆ 380v/50Hz electrical design, stable power supply, rapid cooling, rapid cooling in 6 hours
- ◆ Suitable for 10°C to 32°C ambient temperature

Field proven reliability

- ◆ 7 inches touch screen to display current temperature, history temperature, all alarm records and data.
- ◆ Standard with USB port to download alarm and temperature data
- ◆ Non-flammable HC refrigerant to guarantee users's safety.
- ◆ Emergency stop to protect operator

Key design features

- ◆ Microprocessor-controlled system designed for controlled range of -40°C to -15°C or cabinet space with 1°C increment
- ◆ Settable high temperature and low temperature alarms
- ◆ Optional temperature recorder, storage racks and storage box

Energy Saving

- ◆ Unique door seal design for the minimum loss of cold temperature during a door opening
- ◆ 200mm thickness without CFC insulation to minimize cabinet heat gain and to improve temperature stability.

Technical Specifications



Model	Ambient Temperature (°C)	Temperature Range (°C)	Dimensions W*D*H (mm)	Capacity (L/ cu.ft)	Electricals	Sensor	20GP/40GP/40HQ	USB	LCD Touch Screen
MDF-150H128	10~32	-40 ~ -150	1555*956*147	128L	380V/50Hz	PT100	3	Yes	Yes

Specifications are subject to change without prior notice due to continuous product development



-86°C

Ultra Low Temp Chest Freezers

This product is specially designed and manufactured for long term storage of various biological products, including viruses, germs, erythrocytes, leucocytes and cutis. Applications can be found in blood banks, hospitals, epidemic prevention services, research institutes, laboratories in electronic and chemical plants, bio-logical engineering institutes and marine/fishery companies.



MDF-86H105

MDF-86H485

Key Features of Ultra Low Temp Freezers:

Field proven reliability

- ◆ Unique insulated inner door design for four separate storage compartments to minimize frost buildup inside the chamber.
- ◆ Specialized control system design for a well-balanced operation of cascade refrigeration system.
- ◆ Positive field proven reliability record.

Safety

- ◆ Malfunction alarms including high and low temperature, power failure, sensor error, clean-filter, and extremely high ambient.
- ◆ Capable of producing two types of alarm outputs: audible buzzer and visible flashing light.
- ◆ Door open feature standard and USB

port for temperature data downloading standard on upright models.

- ◆ Remote alarm contacts.

Installation and Application

- ◆ Wide range operating voltage system from 185V to 260v designed to allow units installed in areas with poor voltage condition
- ◆ Suitable for 10°C to 32°C ambient temperature

Energy saving

- ◆ Unique door seal design for the minimum loss of cold temperature during a door opening.
- ◆ High performance VIP insulation panels to minimize cabinet heat gain and to improve temperature stability.

Key design features:

- ◆ Microprocessor-controlled system designed for controlled range of -40°C to -86°C for cabinet space with 1°C increment
- ◆ Settable high temperature and low temperature alarms.
- ◆ Automatic clean-filter alarm and sensor error alert.
- ◆ Adjustable storage shelf height
- ◆ Optional temperature recorder, storage racks and storage box

	Model No.	MDF-86H105	MDF-86H485
Specifications	Self/drawer QTY	-	-
	Cooling	Direct Cooling	Direct Cooling
	Defrost	Manual	Manual
	Refrigerant	Mixed Gas	Mixed Gas
	Power Consumption (kWh/24h)	3.8	11.5
	Noise (db)	50	54.5
	Ambient temperature (C)	10 ~ 32	10 ~ 32
	Temperature range (C)	-40 ~ -86	-40 ~ -86
Cooling System	Compressor Brand/QTY	CUBIGEL/1	SECOP/1
	Sensor	PTC	PTC
	Temperature Controller	Microprocessor	Microprocessor
	Display	Digital Display	Digital Display
Power	Voltage/Frequency (V/Hz)	220/50Hz	220/50Hz
	Power (W)	455W	670W
Material	Current (A)	2.2	3.57
	Inside Material	Stainless Steel	Stainless Steel
	Outside Material	Color Sprayed Steel	Color Sprayed Steel
Size	Insulation	PUF	PUF
	Capacity (L/cu.ft)	105/3.70	485/17.12
	Net/Gross Weight (Kg)	42/45	130/150
	Exterior Size (WxDxH) (mm)	680 x 580 x 935	1695 x 840 x 962
	Interior Size (WxDxH) (mm)	480 x 380 x 665	1455.5 x 525.2 x 674
	Package Size (WxDxH) (mm)	770 x 705 x 1090	1765 x 900 x 1060
Frozen Racks	Racks	4(11x1.6x1)	30(11x1.6x1)
	Boxes (2 Inches)	34	30
	Samples (2ml)	3400	30000
Alarm	High/Low Temperature	Y	Y
	Power Failure	-	-
	Abnormal Voltage	-	-
	Sensor Error	Y	Y
	Filter Screen Check	-	-
	Thermostate Failure	Y	Y
	Low Battery	-	-
	Condenser Clean	-	-
	High Ambient Temperature	-	-
	Door Ajar	-	-
	Castor	Y	Y
	Inside Door	-	-
	Test Hole QTY/Diameter	1/25MM	1/25MM
	USB Port	-	-
Certifications	Chart Recorder	Optional	Optional
	Data Logger	Optional	Optional
	Power Failure Backup System (Alarm)	-	-
	Remote Alarm Port	-	-
	CO2 Backup System	Optional	Optional
	LN2 Backup System	Optional	Optional
		ISO, CE	ISO, CE

Specifications are subject to change without prior notice due to continuous product development

Trufrost -86 ULT Freezers are specially designed for long term storage of various biological products, including viruses, germs, erythrocytes, leucocytes and cutis. They are ideal for blood banks, hospitals, epidemic prevention services, research institutes, laboratories in electronic & chemical plants, biological institutes and fisheries.



MDF-86V838E



MDF-86V588E



MDF-86V408E



MDF-86V340E, MDF-86V188E

Key Features of Ultra Low Temp Freezers:

- Optimized double cascade refrigeration technology for ultra-low temperature application
- Environment friendly CH refrigerant helps save up to 50% on energy costs
- Advanced Vacuum Insulation Panel (VIP) technology enhances sealing and minimizes heat conduction rate resulting in 30% more storage volume
- Suitable for 10°C to 32°C ambient temperature Rapid cooling even at 38°C ambient temperature
- LED display for easy viewing of cabinet temperature, set temperature, ambient temperature, input voltage and early warning for malfunctions
- Derived temperature and alarm record within a month through USB port
- Special noise reduction design with advanced shock absorbers in key component
- Easy to remove and clean dust filter
- White board for records in MDF-86V838 & MDF-86V588
- Double lock system to avoid abnormal door opening

Safety Control System:

- Malfunction alarms for cabinet temperature, voltage or ambient temperature exceeding the range and also for power failure or sensor error
- Audio visual alarm with buzzer & flashing light
- Optional remote alarm through USB port or SMS alarm
- Password protected lockable keyboard

Interior view & key features of ULT Freezers



Changeable sensor box or you could put another sensor from here to monitor or record temperature



- 2 individual inner doors open independently to minimize frost buildup inside the chamber.
- Unique door seal design for minimal loss of cooling
- Stainless Steel handle ensures convenient door openings even in case of frost.



High quality door seals with 5 gaskets, 4 seals for outer door



Green Handle, easy to use with 2 locks



Big condenser for better heat dissipation

Special V.I.P (Vacuum Insulation Panel) design with extra insulation cuts down heat loss by 25%

Touch Screen Display of MDF-86V838 & MDF-86V588

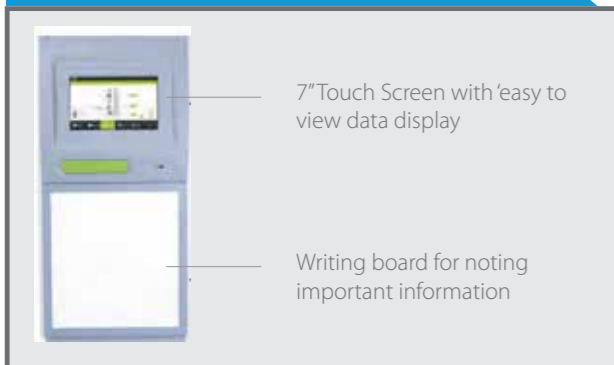

7" Touch Screen with 'easy to view data display

Writing board for noting important information

Digital Display of MDF-86V340II



Other Optional Accessories



Boxes



Racks



Vial Holders



Temperature Recorder

-86°C

Mini Ultra Low Temp Freezers

Trufrost -86 ULT Freezers are specially designed for long term storage of various biological products, including viruses, germs, erythrocytes, leucocytes and cutis. They are ideal for blood banks, hospitals, epidemic prevention services, research institutes, laboratories in electronic & chemical plants, biological institutes and fisheries.



MDF-86V58

Special:

- ◆ Patented technology, mixed refrigerant.
- ◆ Standard remote alarm port
- ◆ Cold storage box loading QTY:2400
- ◆ MRNA vaccine can be stored: 2400pcs
- ◆ 10 visual and audible alarms.

Key Features

- ◆ Wide temperature range : 10°C ~ 32°C ambient temperature can reach -86°C.
- ◆ Accurate Temperature control technology to make the temperature maintain -40°C~-86°C and accuracy 0.1°C.
- ◆ The single level optimization of auto cascade refrigeration system design, less refrigeration component for easy maintenance.
- ◆ SPCC sprayed steel external material and 304 stainless steel inner chamber for friendly using and easy cleaning.

Safety

- ◆ Build-in back-up battery to display temperature and to operate audible and visual alarm system for up to 72 hours without AC power.
- ◆ Visual and audible alarm system:High/low temperature, Sensor error, Thermostat failure alarm, power failure alarm,door switch, ambient temperature alarm, condenser failure alarm, filter check alarm, voltage abnormal alarm, low battery alarm
- ◆ Power failure protection: turn on delay of the cooling system when power failure,restart delay protection.
- ◆ Keyboard lock, password protection to avoid set parameter randomly.
- ◆ Wide available voltage range: 198V~242V.

Humanized design:

- ◆ 4 casters with stopper for easy moving and fixation.
- ◆ 1 adjustable shelves for easy storing.
- ◆ Removable condenser dust gauze convenient for cleaning and maintenance.
- ◆ Removable inner door for user to defrost and clean.
- ◆ Standard Independent Power Switch.



-86°C

Portable Ultra-low Temp Freezers

New Scott Refrigeration

The inner temperature of the refrigerator is within $-86^{\circ}\text{C} \pm 0.2^{\circ}\text{C}$ which is precise and stable, and the display accuracy can reach 0.1°C

The Smallest Volume In The Industry

It can be placed on experiment table, and can use DC24V vehicle power supply or AC100V-240V household power supply.

Humanization Design

The body of freezer is made of high-quality structural sheet steel. The head cover has pulling out lifting yoke and the inner part is equipped with refrigeration sheets of various specifications which make it convenient for experimental samples to be cooled directly.



Intelligent temperature control

It has the high definition digital display with the display accuracy reaching 0.1°C . The inner temperature of the inner part can be changed from -40°C to -86°C . It is easy to operate with friendly interface and clear operating condition.



Alarm system

It has various functions including high temperature alarm, low temperature alarm, sensor fault alarm, Main board communication error which can preserve food in a safer way. The protection of power-on delay and power-off interval ensure the safety of operation. The functions of keyboard lockout system and keyword protection prevent adjusting operation parameters at will. The double-locking design



Human-oriented

The body of freezer is made of high-quality structural steel plate which has the tiny volume and can be placed directly on the experiment table and is easy to store samples directly. It's easy to control and there are lifting yoke on the freezer body for moving. The freezer is equipped with refrigeration packs of various specifications which makes it easy for the direct refrigeration of experimental samples.

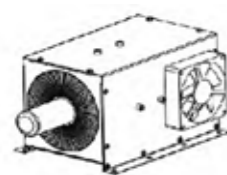

Refrigeration System

It uses new refrigeration which can refrigerate quick and is energy-efficient without using fluorine-containing freezing medium. It has small size and is easy to carry which can use DC24V vehicle power supply or AC100V-240V household power supply. The foaming body and accessory device for heat preservation use soft EVA blind hole foaming materials. It has good heat preservation flexibility and property and flexible shape and has the strong ability to erase strong high frequency noise.



DW-HL1.8

	Model No.	DW-HL1.8
Specifications	Cabinet Type	Upright
	Capacity(L)	1.8
	Internal Size (W*D*H)mm	152*133*87
	External Size (W*D*H)mm	245*282*496
	Package Size (W*D*H)mm	315*385*530
Performance	NW/GW(Kgs)	12/14
	Temperature Range	-40°C - -86°C
	Ambient Temperature	16 - 32°C
	Cooling Performance	-80°C
	Climate Class	N
Construction	Controller	Microprocessor
	Display	Digital Display
	External Material	SPCC steel with powder coating
Alarm	Inner Material	EVA
	External Lock	Yes
Electrical	Temperature	High/Low temperature, High ambient temperature
	System	Sensor error, Main board communication error
	Power Supply (V/Hz)	DC24V/AC100V-240V50
	Rated Power (W)	60
Certifications	Input Power (W)	80
	Power Consumption (KWh/24h)	2.24
	Rated Current(A)	0.46
		ISO, CE

*The model, parameters and performance specified in this brochure may be changed without prior notice because of product upgrading.
*There may be differences between the product images shown in this brochure and the actual products. When you are buying any product, please check the actual product.



Scope of Application

It can apply to physical evidence for public security, blood station, hygiene epidemic-protection system, academic institutions, electron industry, chemical industry, bioengineering, laboratories in colleges and universities, military enterprises, pelagic fishery companies, etc.

Performance Data / Cooling Curve

Environment temperature: 25°C
Container: 1.5ml minitype needle tubing *48
Cooling time: 25°C - -80°C 120min

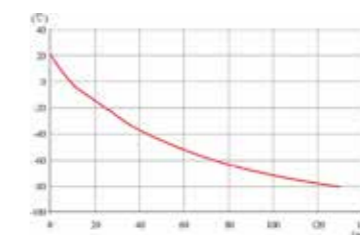

Put in a 1.5ml mini type test tube (water injected) when powering on

Environment temperature: 25°C
Container: 1.5ml minitype needle tubing *48
Cooling time: 25°C - -80°C 3min

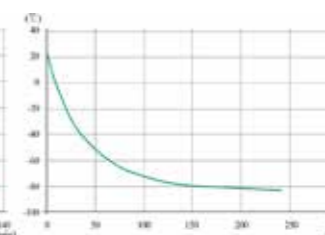

Put in a 1.5ml mini type test tube (water injected) when running at -80°C

-40°C

Low Temp Freezers

Designed to store vaccines, blood plasma, biological materials and ideal for use in electronic and chemical laboratories, epidemic prevention centres, hospitals, animal husbandry, blood banks and research institutes.



Key Features of Low Temp Upright Freezers:

- ◆ Unique refrigeration system for faster cooling
- ◆ Eco-friendly and energy saving CH refrigerant
- ◆ Independent inner door to prevent cooling loss
- ◆ Adjustable shelves with plastic coated steel
- ◆ Built in lock for safety

Key Features of Low Temp Chest Freezers:

- ◆ Unique refrigeration system ensures faster cooling and better stability
- ◆ Energy efficient and environment friendly R 290 refrigerant
- ◆ Lock for safety

Safety Control System:

- ◆ Multiple alarm for high/ low temperature & sensor malfunction
- ◆ Password protected lockable keyboard
- ◆ Micro-computer based temperature control system
- ◆ Ensures high precision and uniform cooling



	Model No.	MDF-40V50	MDF-40V278W	MDF-40V528	LTF-400	
Specifications	Shelf/Drawer	Shelves	Drawer	Shelves		
	Cooling Method	Direct Cooling	Direct Cooling	Direct Cooling	Direct Cooling	
	Defrost	Manual	Manual	Manual	Manual	
	Refrigerant	HFC	R290	R290	R290	
	Power Consumption (kWh/24h)	3.5	1.5	6.7	1.2	
	Noise (db)	50	50	55		
	Ambient Temperature (C)	10 ~ 32	10 ~ 32	10 ~ 32	10 ~ 32	
	Temperature Range (C)	-10 ~ -40	-30 ~ -40	-20 ~ -40	-30 ~ -40	
	Cooling System	Compressor Brand QTY	SECOP/1	CUBIGEL/1	SECOP/1	HUAYI /1
		Condenser	Finned	Inside Foaming	Copper Tube	Wire Tube
Sensor		NTC	NTC	NTC		
Temperature Controller		Microprocessor	Microprocessor	Microprocessor		
Display		Digital Display	Digital Display	Digital Display	NA	
Power	Voltage/Frequency (V/Hz)	220V/50Hz	220V/50Hz	220V/50Hz	220V/50Hz	
	Power (W)	250W	185W	345W	288W	
	Current (A)	2.5	1.5	2.9	2.4	
Material	Inside Material	Stainless Steel	Color Sprayed Steel	Color Sprayed Steel	Color Sprayed Steel	
	Outside Material	Color Sprayed Steel	Color Sprayed Steel	Color Sprayed Steel	Color Sprayed Steel	
	Insulation	PUF	PUF	PUF	PUF	
Size	Capacity (L/Cu.ft)	50/1.76	278/9.81	528/18.64	400	
	Net/Gross Weight (Kg)	75/95	110/120	160/180	56	
	Exterior Size (WxDxH) (mm)	540 x 620 x 1145	659 x 600 x 1694	900 x 818.5 x 1828	1234 x 670 x 908	
	Interior Size (WxDxH) (mm)	361 x 429 x 406	480 x 415 x 1460	(651 x 631.5 x 635)x2		
	Package Size (WxDxH) (mm)	690 x 770 x 1170	710 x 650 x 1800	997 x 912 x 1982		
Alarm	High/Low Temperature	Y	Y	Y		
	Power Failure	N	N	Y		
	Sensor Error	Y	Y	Y		
	Filter Screen Check	N	N	N		
	Temperature Controller Failure	Y	Y	Y		
	Low Battery	N	N	N		
	Condenser Clean	N	N	N		
	High Ambient Temperature	N	N	N		
	Door Ajar	N	Y	N		
	Accessories	Foot	N	N	Y	
Castor		Y	N	Y		
Inside Door		Y	7 Drawer	9 Drawer x 2		
Test Hole QTY/Diameter		Optional	N	2 x 25mm		
USB Port		N	N	N		
Power Failure Backup System (Alarm)		N	8h	8h		
Remote Alarm Port		N	N	Y		
Other		Certification	ISO9001, 13485, 14001, CE	ISO9001, 13485, 14001, CE	ISO9001, 13485, 14001, CE	ISO9001, 13485, 14001, CE

Specifications are subject to change without prior notice due to continuous product development

**-25°C &
2 ~ 8°C**

Combined Freezers & Refrigerators

The Trufrost Combined Freezer & Refrigerator comes with two separate chambers equipped with independent refrigeration circuits. The freezer chamber comes with a vacuum release hole design for opening the door frequently for short durations, and is designed to store vaccines, blood plasma and many other biological materials. The refrigerator section is suitable for storage of medicines, vaccines, reagents and biomedical products.

RELIABILITY

- ◆ Two temperature control systems with double door construction.
- ◆ Flexible and easy storage by height-adjustable shelf trays
- ◆ Maintains the quality of the samples during preservation
- ◆ 2 completely independent chambers with their own temperature displays

KEY FEATURES

- ◆ Refrigerator chamber with foaming heated glass door, you can observe the condition of its internal items
- ◆ Freezer chamber with foaming solid door, high insulation design.
- ◆ The separate top and bottom doors suppress cold air leakage and 2 completely independent chambers each has its own temperature control.



MDF-25V300RF

FEATURES

- ◆ Height-adjustable shelf trays allow you to adjust the inside of the chambers according to the size of the samples. By changing the height of the shelf trays, the unit can accommodate various sizes of samples including stored in your conventional models.
- ◆ Door latch with provision for a padlock hole for extra protection of samples.
- ◆ Equipped with separate doors that suppress the leakage of cold air during opening and closing of the doors, and manual defrosting that helps avoid temperature impact on the samples.

EASY TO CLEAN

- ◆ Top and bottom chambers are equipped with 2 independent refrigeration circuits that enables separate temperature settings and defrosting for the two chambers.
- ◆ Corrosion resistant paint, easy to clean, will not rust.

SAFETY DESIGN

- ◆ To securely preserve/manage the valuable samples, in addition to a standard-feature door lock, a hole in the latch allows a padlock to be attached.
- ◆ Security functions that help protect valuable samples with a temperature control capability that inhibits the change in temperature inside the chamber, and an alarm/security function that prevents errors, the unit maintains the quality of the preserved samples. Temperature recorder (optional)
- ◆ Front-mounted display/control panel located at convenient height for easy access
- ◆ Insulated door with gasket for sample protection and uniformity



	Model No.	MDF-25V300RF
Specifications	Shelf/Drawer	6
	Cooling Method	Direct Cooling
	Defrost	Manual
	Refrigerant	R290
	Power Consumption (kWh/24h)	-
	Noise (db)	46
	Ambient Temperature (C)	10 ~ 32
	Temperature Range (C)	Freezer: -10°C ~ -25°C Refrigerator: 2°C ~ 8°C
Cooling System	Compressors	2
	Sensor	NTC
	Temperature Controller	Microprocessor
	Display	Digital Display
Power	Voltage/Frequency (V/Hz)	220V/50Hz
	Power (W)	310W
	Current (A)	2.12A
Material	Inside Material	Color Sprayed Steel
	Outside Material	Color Sprayed Steel
	Insulation	PUF
Size	Capacity (L/Cu.ft)	102 + 198
	Net/Gross Weight (Kg)	-
	Exterior Size (WxDxH) (mm)	650 x 618 x 1974
	Interior Size (WxDxH) (mm)	Freezer: 461 x 465 x 60 Refrigerator: 565 x 480 x 75
	Package Size (WxDxH) (mm)	-
	Alarm	High/Low Temperature
Accessories	Power OFF	N
	Sensor Malfunction	Y
	Temperature Controller Malfunction	Y
	Door Ajar	Y
	Castor	N
Other	Test Hole	2/25
	Lock	Y
	Remote Alarm	Y
	Certifications	ISO14001, ISO9001, ISO13485, ISO45001, CE, FDA Listed

Specifications are subject to change without prior notice due to continuous product development



-10°C
~ -25°C

2°C
~ 8°C

Convertible Freezers & Refrigerators

This unique biomedical refrigerator from Trufrost can either be used as a freezer or can be converted into a refrigerator depending upon the items to be stored thanks to its precise digital temperature controller. It is a frost free machine that comes with an automatic defrost.



UF/C-500 Premia



Key Features:

- ◆ **Electrical Temperature Control** - lets you adjust inside temperature to precisely the desired setting
- ◆ **Control Lock** - Prevents accidental changing of preferred temperature setting
- ◆ **Digital Display**
 - ◆ displays inside temperature in Fahrenheit or Celsius mode
 - ◆ provides positive feedback that unit is in lock or unlock mode
 - ◆ tells you when unit is in fast freeze cycle
 - ◆ tells you stored items are being kept in the proper environment
- ◆ **Convection-Freeze System** - Continually surrounds stored items with optimal air circulation to ensure maintenance of perfect temperature, regardless of location within the unit.
- ◆ **Fast Freeze Feature** - turn the unit into a quick freeze system, driving the internal temperature to 20-25 degree below zero.

	Model No.	UF/C-500 Premia
Specifications	Drawer	5
	Cooling Method	Direct Cooling
	Defrost	Automatic
	Refrigerant	R600a
	Power Consumption (24h)	-
	Ambient Temperature (C)	16 ~ 43
	Temperature Range (C)	-10°C ~ -25°C 2°C ~ 8°C
Power	Voltage/Frequency (V/Hz)	220V/50Hz
Size	Capacity (L/Cu.ft)	500
	Exterior Size (WxDxH) (mm)	710x708.5x1728
	Alarm	High/Low Temperature
Accessories	Power OFF	N
	Sensor Malfunction	Y
	Temperature Controller Malfunction	Y
	Door Ajar	Y
	Castor	Y
	Test Hole	N
	Lock	Y
Other	Remote Alarm	N
	Certifications	CE

Specifications are subject to change without prior notice due to continuous product development

Trufrost upright freezers and no-frost chest freezers are designed to store vaccines, biological materials etc., and are ideal for use in electronic and chemical laboratories, epidemic prevention centres, hospitals, animal husbandry, blood banks and research institutes. They also feature precise temperature control and a digital temperature indicator. Trufrost No-Frost Chest Freezers make manual defrosting a thing of the past. They also come with a full set of baskets for segregated loading while the multi-dimensional air flow ensures uniform cooling inside the cabinet.



MDF-25V278W,
MDF-25V328E



UF-371 Premia



	Model No.	MDF-25V278W	MDF-25V328E	UF-371 Premia
Specifications	Shelf/Drawer	Shelves	Shelves	7
	Cooling Method	Direct Cooling	Direct Cooling	Ventilated
	Defrost	Manual	Manual	Frostfree
	Refrigerant	R290	R290	R600a
	Power Consumption (kWh/24h)	1.5	3	-
	Noise (db)	46	46	-
	Ambient Temperature (C)	10 ~ 32	10 ~ 32	16 ~ 43
	Temperature Range (C)	-10 ~ -25°C	-10 ~ -25°C	-25°C
	Cooling System	Compressor Brand QTY	DONPERN/1	CUBIGEL/1
Sensor		NTC	NTC	NTC
Temperature Controller		Microprocessor	Microprocessor	Microprocessor
Display		Digital Display	Digital Display	Digital Display
Power	Voltage/Frequency (V/Hz)	220V/50Hz	220V/50Hz	220V/50Hz
	Power (W)	180W	280W	-
	Current (A)	1.5	1.4	
Material	Inside Material	Color Sprayed Steel	Color Sprayed Steel	Color Sprayed Steel
	Outside Material	Color Sprayed Steel	Color Sprayed Steel	Color Sprayed Steel
	Insulation	PUF	PUF	PUF
Size	Capacity (L/Cu.ft)	278/9.81	328/11.58	371
	Net/Gross Weight (Kg)	105/115	113/131	
	Exterior Size (WxDxH) (mm)	659 x 600 x 1694	673 x 676 x 1886	595x712x1860
	Interior Size (WxDxH) (mm)	480 x 415 x 1460	508 x 455 x 1393	-
	Package Size (WxDxH) (mm)	710 x 650 x 1800	770 x 770 x 2040	-
	Alarm	High/Low Temperature	Y	Y
Power OFF		N	Y	N
Sensor Malfunction		Y	Y	Y
Temperature Controller Malfunction		Y	Y	Y
Door Ajar		Y	Y	Y
Accessories	Castor	N	Y	Y
	Test Hole	N	Optional	N
	Lock	N	Y	Y
	Remote Alarm	N	Y	N
Other	Certifications	ISO9001, 13485, 14001, CE	ISO9001, 13485, 14001, CE	CE

Specifications are subject to change without prior notice due to continuous product development

Key Features:

- ◆ Unique refrigeration system ensures faster cooling and better stability
- ◆ Environment friendly refrigerant
- ◆ Accurate microprocessor controller to ensure consistent cabinet temperature -10°C ~ -25°C and increment 0.1°C for MDF Model & -10°C ~ -18°C for other models
- ◆ Adjustable height of plastic coated fabric grid, more uniform temperature (MDF Models)
- ◆ Lock for safety
- ◆ Temperature Display



-20°C Biomedical Freezers

Trufrost upright freezers are designed to store vaccines, biological materials etc., and are ideal for use in electronic and chemical laboratories, epidemic prevention centres, hospitals, animal husbandry, blood banks and research institutes. They also feature precise temperature control and a digital temperature indicator. They also come with a full set of baskets for segregated loading while the multi-dimensional air flow ensures uniform cooling inside the cabinet.

Key Features:

- ◆ Unique refrigeration system ensures faster cooling and better stability
- ◆ Environment friendly refrigerant
- ◆ Accurate microprocessor controller to ensure consistent cabinet temperature
- ◆ Lock for safety
- ◆ Temperature Display



UF-330 Premia



UF-220 Premia

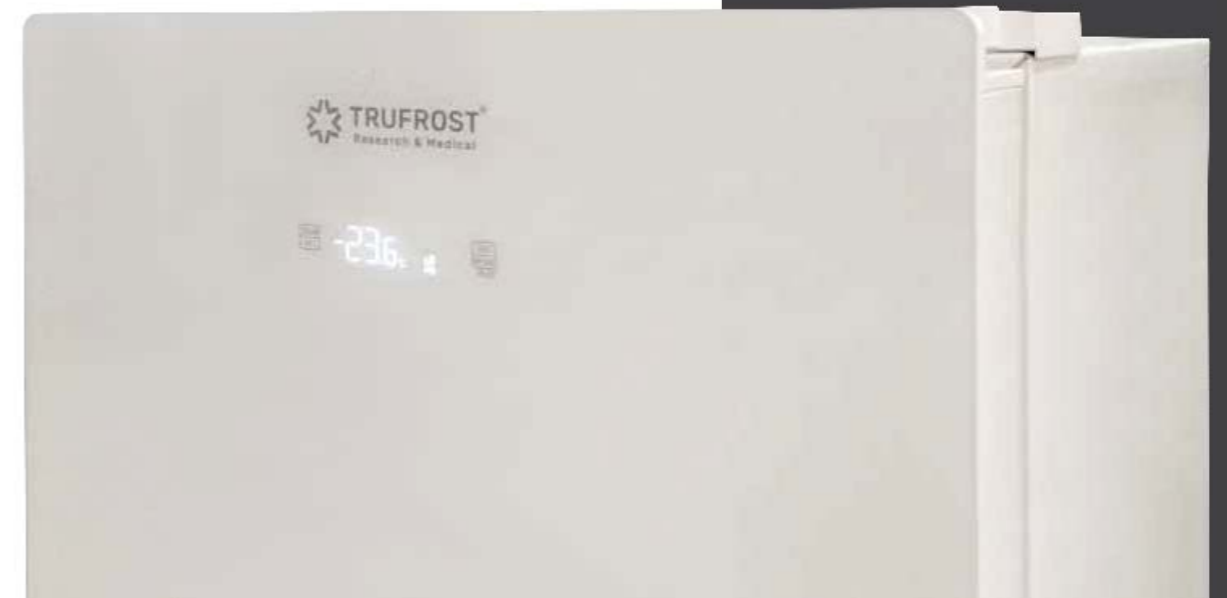

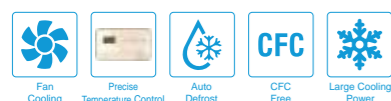

No Frost Convertible Chest Freezers / Chillers

Trufrost no-frost chest freezers are designed to store vaccines, biological materials etc., and are ideal for use in electronic and chemical laboratories, epidemic prevention centres, hospitals, animal husbandry, blood banks and research institutes. No-Frost Chest Freezers make manual defrosting a thing of the past. They also come with a full set of baskets for segregated loading while the multi-dimensional air flow ensures uniform cooling inside the cabinet.

Key Features:

- ◆ Self-adaptive frost system
- ◆ Precise temperature control
- ◆ Multi-dimensional wind circulation
- ◆ Embedded handle
- ◆ Digital temperature indicator
- ◆ 2 baskets for NF-150



NF-150



	Model No.	UF-220 Premia	UF-330 Premia	NF-150
Specifications	Drawer	6	8	2 Basket
	Cooling Method	Direct Cooling	Direct Cooling	With Fan
	Defrost	Manual	Manual	No Frost
	Refrigerant	R-600A	R600a	R290
	Power Consumption (24h)	160W	170W	-
	Ambient Temperature (C)	10 ~ 32	10 ~ 32	10 ~ 32
	Temperature Range (C)	≤-20°C	≤-20°C	≤-20°C
Power	Voltage/Frequency (V/Hz)	220V/50Hz	220V/50Hz	220V/50Hz
Size	Capacity (L/Cu.ft)	200	300	97W
	Exterior Size (WxDxH) (mm)	515x620x1300	595x552x1720	714 x 550 x 903
Alarm	High/Low Temperature	N	N	N
	Power OFF	N	N	N
	Sensor Malfunction	N	N	N
	Temperature Controller Malfunction	N	N	N
	Door Ajar	N	N	N
	Remote Alarm	N	N	N
Accessories	Castor	N	N	Yes
	Test Hole	N	N	N
	Lock	Y	Y	Y
	Remote Alarm	N	N	N
Other	Certifications	CE	CE	ISO9001, CE

Specifications are subject to change without prior notice due to continuous product development

-18°C
~ **-22°C**

Traditional Visi Freezers

Trufrost upright visi freezers are known for their reliability and temperature management. You can choose between Two models that are available in 400 and 1000 litre capacities and are fitted with LED lights to enhance the quality of display. They come with a digital temperature display and a ventilated cooling system with automatic defrost.



Visi Freezers - Premia Series (With top mounted compressors)

These Trufrost Premia Series plug-in type 2 & 3 glass door upright Coolers & Freezers come with top mounted compressors. They provide an ultra rich and pleasing 'top to bottom' view of the displayed foodstuff – be it ice creams or any other packaged food, whether frozen or chilled. They are extremely reliable and work on a ventilated cooling system. The Freezers are specially designed with 2 strong compressors with automatic defrost. The cabinet interiors of both - the Freezers and Chillers come with LED lights to enhance the quality of display.

Key Features

- Forced air circulation
- Adjustable shelves
- Interior LED lights
- Universal wheels, front with brake
- Double pane glass including Low E in Visi Coolers
- Triple pane glass with heated film in Visi Freezers
- Self Closing doors
- Self evaporating drip tray
- Low-maintenance condenser
- Standard ambient for Visi Coolers +35°C at 65%RH and for Visi Freezers +25°C at 60%RH
- Auto-defrost in Visi Freezers



VF-400NF
Visi Freezer



VF-1000NF
2 Door Visi Freezer
New upgraded model with
2 compressors



VF-1250 Premia



VF-1800 Premia

Technical Specifications of Visi Freezers



Specification	Gross Volume (Litres)	Dimensions w x d x h (mm)	Temperature Range	Power (w)	Lock	Defrost	No. of Lids / Doors	No. of Shelves	Interior Light	Wheels / Castors	No. of Compressors	Refrigerant
VF-400NF	400	26 x 28 x 78	-18°C ~ -22°C	570	Yes	Automatic	1	5	2 LEDs	Yes	1	R404a
VF-1000NF	950	48 x 28 x 78	-18°C ~ -22°C	1250	Yes	Automatic	2	10	2 LEDs	Yes	2	R404a

Electricals: 220V/50Hz/1 Phase

Specifications are subject to change without prior notice due to continuous product development

Technical Specifications



Model	Volume (L)	Door type	Shelves	Power	Dimensions (wxdxh) mm	Temperature range	Refrigerant	No. of Compressors
VF-1250 Premia	1250	2 Hinge	10	1472W	1260x750x2092	-18°C ~ -22°C	R404a	2
VF-1800 Premia	1800	3 Hinge	15	1850W	1880x750x2092	-18°C ~ -22°C	R404a	2

Electricals: 220V/50Hz/Single Phase

Specifications are subject to change without prior notice due to continuous product development

4° ± 1°C Blood Bank Refrigerators

Blood storage requires specially designed equipment that must comply with international standards. Trufrost Bank Refrigerators are reliable for storing blood and are ideal for blood banks, hospitals and the medical industry. They can also be used to store pharmacy and biological products in hospitals and disease prevention centers.



MBC-4V108

MBC-4V208

MBC-4V658

MBC-4V1008

Key Features:

- ◆ Advanced forced-air cooling system, large airflow with optimised air channels for inner temperature consistency and special finned evaporator.
- ◆ Inner light and heated double pane glass doors ensure clear display without condensation
- ◆ Microprocessor control with digital temperature display
- ◆ Auto-defrost function ensures good performance in high temperature and high humidity areas
- ◆ Safety lock prevents unauthorized access
- ◆ Large digital display for easier observation
- ◆ SUS shelves for convenient storage of blood bags
- ◆ Self-closing doors



Safety Control System:

- ◆ Alarm mode monitors ambient temperature and system state to ensure safety and reliability of storage conditions.
- ◆ High/Low temperature alarm, thermostat malfunction alarm, power failure alarm in 72 hours, battery backup malfunction alarm, condenser abnormality alarm.
- ◆ Audio and visual alarm
- ◆ USB port, optional temperature controller with thermal printer to track temperature curve
- ◆ Password protection to prevent random parameter change

	Model No.	MBC-4V108	MBC-4V208	MBC-4V658	MBC-4V1008
Specifications	Shelf/Drawer	Shelves/2	Shelves/4	Shelves/12	Drawers/12
	Cooling	Forced - Air Cooling	Forced - Air Cooling	Forced - Air Cooling	Forced - Air Cooling
	Defrost	Auto	Auto	Auto	Auto
	Refrigerant	R134a	R134a	R134a	R134a
	Power Consumption (kWh/24h)	1.95	2.22	6.31	8.53
	Noise (db)	49.6dB(A)	51.2dB(A)	51.2dB(A)	53.6dB(A)
	Ambient Temperature (C)	10 ~ 32	10 ~ 32	10 ~ 32	10 ~ 32
	Temperature Range (C)	4 ± 1	4 ± 1	4 ± 1	4 ± 1
Cooling System	Compressor Brand/QTY	Embraco/1	Embraco/1	SECOP/1	SECOP/1
	Sensor	NTC	NTC	NTC	NTC
	Temperature Controller	Microprocessor	Microprocessor	Microprocessor	Microprocessor
	Display	Digital Display	Digital Display	Digital Display	Digital Display
Power	Voltage/Frequency (V/Hz)	220V/50Hz	220V/50Hz	220V/50Hz	220V/50Hz
	Power (W)	160	200	364	513
	Current (A)	0.6	0.8	2.42	2.37
Material	Inside Material	Stainless Steel	Stainless Steel	Stainless Steel	Stainless Steel
	Outside Material	Color Sprayed Steel	Color Sprayed Steel	Color Sprayed Steel	Color Sprayed Steel
	Insulation	PURF	PURF	PURF	PURF
Size	Capacity (L/Cu.ft)	108/3.81	208/7.34	658/23.23	1008/35.59
	Blood Bags (450ml)	66	132	360	576
	Net/Gross Weight (Kg)	50/55	67/75	165/195	256/286
	Exterior Size (WxDxH) (mm)	522 x 600 x 1050	522 x 600 x 1550	1220 x 648 x 1885	1220 x 878 x 1885
	Interior Size (WxDxH) (mm)	432 x 462 x 478	432 x 462 x 978	432 x 462 x 478	1100 x 684 x 1325
	Package Size (WxDxH) (mm)	572 x 685 x 1070	572 x 685 x 1570	572 x 685 x 1070	1300 x 960 x 2080
Alarm	High/Low Temperature	Y	Y	Y	Y
	Power OFF	Y	Y	Y	Y
	Temperature Controller Malfunction	Y	Y	Y	Y
	Backup Battery Malfunction	Y	Y	Y	Y
	Ambient Temperature	10 ~ 32	10 ~ 32	10 ~ 32	10 ~ 32
	Backup Battery Alarm for Power Off	72h	72h	72h	72h
Accessories	Castor	Y	Y	Y	Y
	Outer Door/Type	1/Heating & Foam Glass Door	1/Heating & Foam Glass Door	2/Heating & Foam Glass Door	2/Heating & Foam Glass Door
	Inner Door	2	2	6	6
	Test Hole	1/25mm	1/25mm	1/25mm	1/25mm
	Thermal Printer	Y	Y	Y	Y
	Light	LED	LED	LED	LED
	Temperature Recorder	Optional	Optional	Optional	Optional
Other	Certifications	ISO9001, 13485, 14001, CE	ISO9001, 13485, 14001, CE	ISO9001, 13485, 14001, CE	ISO9001, 13485, 14001, CE

Specifications are subject to change without prior notice due to continuous product development

2~8°C

Explosion Proof Lab Refrigerators

2~8°C explosion proof refrigerator is specially designed to store medicines, vaccines, reagents and bio-medical products with anti explosion function.



MPC-5V416EX

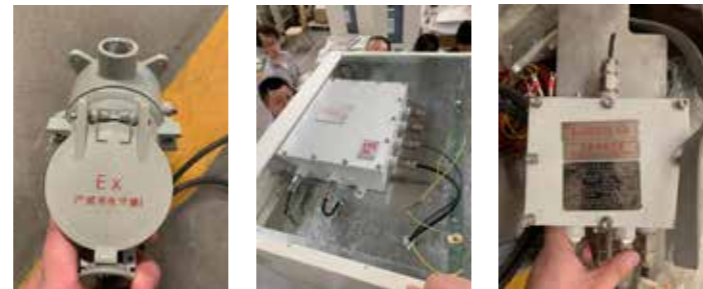

Features

- ◆ Anti-explosion compressor and controller system to protect inner storage more safely.
- ◆ Inner SS 304 material
- ◆ Accurate temperature controller, ensure the inside temperature within 2~8°C and accuracy 0.1 °C.
- ◆ Specially designed forced-air cooling system, ensure frost-free cabinet and good temperature uniformity.
- ◆ Suggested ambient temperature: 10~32°C.
- ◆ Foamed door with for better heat protection
- ◆ Color spray steel plate inner chamber for friendly using and easy cleaning.
- ◆ 4 casters 2 with stopper and 2 adjustable feet for easy moving and fixation.
- ◆ 5 adjustable steel wire shelves for easy storing.
- ◆ 1 Standard test hole for convenient installation of temperature recorder
- ◆ Special designed service-free drainage system, ensure no water in the cabinet.
- ◆ Auto on/off LED light with manual switch on control panel.

Safety

- ◆ Safety door lock and controller setting password to prevent unauthorized access.
- ◆ Build-in back-up battery to display temperature and to operate audible and visual alarm system for up to 8 hours without AC power.
- ◆ Auto on/off cooling fan to prevent cold air from leaking out when the door is opening.
- ◆ Visual and audible alarm system: High/low temperature, power failure, sensor failure, door ajar
- ◆ Power failure protection: turn on delay of the cooling system after power failure.
- ◆ Controller error protection: the cooling system will remember the normal working cycle and keep working depending on this memory when controller or two sensor failed.
- ◆ Keyboard lock, password protection to avoid set parameter randomly.



	Model No.	MPC-5V416EX
Specifications	Shelf/Drawer	Shelves/5
	Cooling	Forced - Air Cooling
	Defrost	Frost Free
	Refrigerant	R290a
	Power Consumption (kWh/24h)	2.94
	Noise (db)	50
	Ambient Temperature (C)	10 ~ 32
	Temperature Range (C)	2~8
Cooling System	Compressor QTY	1
	Sensor	NTC
	Temperature Controller	Microprocessor
	Display	Digital Display
Power	Voltage/Frequency (V/Hz)	220V/50Hz
	Power (W)	290
	Current (A)	1.26
Material	Inside Material	Color sprayed steel
	Outside Material	Color Sprayed Steel
	Insulation	PURF
Size	Capacity (L/Cu.ft)	416/14.69
	Net/Gross Weight (Kg)	150/165
	Exterior Size (WxDxH) (mm)	785x552x1927mm
	Interior Size (WxDxH) (mm)	685x429x1380mm
	Package Size (WxDxH) (mm)	880x640x2100mm
Alarm	High/Low Temperature	Y
	Power failure	Y
	Thermostat failure	Y
	Backup Battery Malfunction	/
	Ambient Temperature	10 ~ 32
	Voltage abnormality alarm	/
	Door Ajar	Y
Accessories	Castor	Y
	Outer Door/Type	1/Heating & Foam
	Door Lock	1
	Test Hole	1/25mm
	USB Port	/
	Light	LED
	Temperature Recorder	Optional
Other	Certifications	ISO; CE

Specifications are subject to change without prior notice due to continuous product development

2~8°C Pharmacy Refrigerators

Trufrost pharmacy refrigerators are suitable for installation in drug stores, pharmaceutical companies, hospitals, epidemic prevention centers and clinics.



MPC-5V60G



MPC-5V100



MPC-5V316

Ergonomic Design

- Optimized space utilization design with multi-level and adjustable shelf height to accommodate storage requirement of pharmaceutical products of various kinds.
- Safety lock to prevent unauthorized access
- Caster design and leveling legs
- LED Interior light

Forced Air-Cooling System

- Advanced forced cooling system to keep inside temperature stable and uniform. Finned evaporator with special cyde design of forced air cooling system to assure no-frost inside

Reliability and Key Features

- High efficiency specialty compressor with known field reliability.
- Permanently lubricated cooling fan for safety and longevity.
- Forced-aircooling with optimized air distribution system designed.
- To achieve maximum temperature uniformity and stability.

- Optimized refrigeration system design for more effective cooling and Speedy recovery
- Temperature variation within $\pm 3^{\circ}\text{C}$
- Adjustable temperature range 2-8°C
- Microprocessor control, digital display, and temperature adjustment with an increment of 0.1°C
- Large digital display screen.

Characteristic Function

- Safety door lock design to avoid door ajar
- Big digital screen display for easy observation
- Optional testing hole
- Adjustable shelves
- Inner light design for a clear display

Safety

- Equipped with a complete temperature alarm system featuring audible buzzer and visible flashing light.
- Capable of alerting failures due to high and low temperature sensor error, door ajar, power failure and low battery.



	Model No.	MPC-5V60G	MPC-5V100	MPC-5V316	
Specifications	Shelf/Drawer	Shelves/2	Shelves/3	Shelves/5	
	Cooling	Forced - Air Cooling	Forced - Air Cooling	Forced - Air Cooling	
	Defrost	Auto	Auto	Auto	
	Refrigerant	R600a	R600a	R290	
	Power Consumption (kWh/24h)	0.84	1.15	1.78	
	Noise (db)	50	50	50	
	Ambient Temperature (C)	10 ~ 32	10 ~ 32	10 ~ 32	
	Temperature Range (C)	2~8	2~8	2~8	
	Cooling System	Compressor QTY	1	1	1
		Sensor	NTC	NTC	NTC
Temperature Controller		Microprocessor	Microprocessor	Microprocessor	
Display		Digital Display	Digital Display	Digital Display	
Power	Voltage/Frequency (V/Hz)	220V/50Hz	220V/50Hz	220V/50Hz	
	Power (W)	72	80	228	
	Current (A)	0.59	0.8	1.2	
Material	Inside Material	Color sprayed steel	HIPS	Color Sprayed Steel	
	Outside Material	Color Sprayed Steel	Color Sprayed Steel	Color Sprayed Steel	
	Insulation	PURF	PURF	PURF	
Size	Capacity (L/Cu.ft)	60/2.11	100/3.53	316/11.15	
	Net/Gross Weight (Kg)	33/37	35/38	92.5/100	
	Exterior Size (WxDxH) (mm)	495x450x710	505x510x875	660x555x1915	
	Interior Size (WxDxH) (mm)	410x315x560	385x356x737	540x425x1380	
	Package Size (WxDxH) (mm)	558x510x760	580x580x940	720x680x2040	
	Alarm	High/Low Temperature	Y	Y	Y
Power failure		Y	Y	Y	
Thermostat failure		Y	Y	Y	
Backup Battery Malfunction		/	/	/	
Ambient Temperature		10 ~ 32	10 ~ 32	10 ~ 32	
Voltage abnormality alarm		/	/	/	
Door Ajar		Y	Y	Y	
Accessories		Castor	/	Y	Y
		Outer Door/Type	1/Glass/Low-E	1/Glass door	1/Glass /Low-E
		Door Lock	1	1	1
	Test Hole	1/25mm	Optional	1/25mm	
	USB Port	/	/	Y	
	Light	LED	LED	LED	
Other	Temperature Recorder	Optional	Optional	Optional	
	Certifications	ISO; CE	ISO	ISO; CE	

Specifications are subject to change without prior notice due to continuous product development

1~8°C Pharmacy Refrigerators

Trufrost Pharmacy Refrigerators are designed to store pharmaceuticals, medicines and other related products and are ideal for drug stores, pharmaceutical companies, hospitals, epidemic prevention centers and clinics.



Model No.	FKS 471
Dimensions (W*D*H)mm	595*653*1840
Net Capacity (L)	380
Cooling System	Ventilated
Temperature Range	1~8°C
No. of Shelves	3 + 1
Interior Light	Yes
Compressor	ZEL/ZEL
Display	Digital Display
Digital Thermostat	Dixell
Refrigerant	R134a/R600a
Casters	2 rear casters
Power Supply (V/Hz)	220/50
Lock	Yes
Certifications	ISO, CE

Key Features:

- ◆ White pre-painted solid door
- ◆ Digital Thermostat
- ◆ Lock and key
- ◆ Fan assisted cooling system
- ◆ Reversible self-closing door
- ◆ Roll bond plate with fan for chiller
- ◆ 7 layer of evaporator as shelves for freezer
- ◆ Two front adjustable feet, two rear wheels

FKS 471

2~8°C Pharmacy Refrigerators

Trufrost Pharmacy Refrigerators are designed to store pharmaceuticals, medicines and other related products and are ideal for drug stores, pharmaceutical companies, hospitals, epidemic prevention centers and clinics.



MVC-360



MVC-800

Key Features:

- ◆ Advanced forced-air cooling system, large airflow with optimized air channels to guarantee inner temperature consistency. The special finned evaporator ensures no-frost and effective temperature management within $\pm 3^{\circ}\text{C}$, the adjustable temperature range: 2~8°C.
- ◆ Microprocessor control with digital temperature display with an accuracy of 0.1°C
- ◆ Multi-level and adjustable shelves for various dimensions of pharmaceutical products, making full use of the space.
- ◆ Inner light for clear display

Safety Control System:

- ◆ High/Low temperature alarm, thermostat malfunction alarm, door ajar alarm and power failure alarm. The start delay function provides protection of device.
- ◆ Audio and visual alarm
- ◆ USB port, optional temperature controller with thermal printer to track temperature curve
- ◆ Password protected lockable keyboard to prevent random parameter changes
- ◆ Optional remote control mode by Wi-Fi monitor

Technical Specifications

Model	Volume	Exterior Dimensions (W*D*H/mm)	Interior Dimensions (W*D*H/mm)	No. of Shelves	Net Weight	Power (W)	Temp Range (°C)	Optional Accessories
MVC-360	360L	615*612*1968	525*480*1524	6	75	175	2°C ~ 8°C	Electronic Control (Touch), USB Port To Download data, RH Display, Temp Alarm
MVC-800	835L	1190*660*2030	1100*530*1555	8	142kg	460W	2°C ~ 8°C	Test Hole, Thermal Printer, Temp Recorder, Waterproof Socket

Electricals: 220V/50Hz/Single Phase

Specifications are subject to change without prior notice due to continuous product development



2~8°C Ice Lined Refrigerator



YC-150EW



YC-275EW

Constant Temperature under Intelligent Control

High-precision computerized temperature control system: The cabinet has built-in high-sensitivity temperature sensors, ensuring a constant temperature inside it.

Security System

The well-developed audible & visual alarm system (with multiple audible & visual alarm functions, such as high temperature alarm, low-temperature alarm, sensor failure alarm, door opening alarm, power outage alarm) makes it safer for storage.

High-efficiency Refrigeration

Equipped with environmentally-friendly Freon-free refrigerant R290 and compressor supplied by an international famous brand, the refrigerator is characterized by fast refrigeration and low noise. When there is power outage, the holdover time is up to 24 hours, which provides sufficient time for transferring samples.

Human-oriented Design

Trufrost 2 ~ 8°C ice-lined refrigerators are specially designed for up to 43°C high ambient temperature zones. Start-delay time setting function (solving the problem of simultaneous startup of batch products after power failure);



Control Panel

4-digit LED high-brightness digital display enables; users to set temperature within a range; from 2~8°C, and the precision of temperature display reaches 0.1°C.



Security System

The well-developed alarm system (high and low temperature alarm, sensor failure alarm, power failure alarm, low battery alarm, etc.) makes it safer for storage; Turn-on delay & stopping interval protection; The door is equipped with a lock, preventing it from unauthorized opening;



Refrigeration System

Equipped with environmentally-friendly CFC Refrigerant R290 and compressor supplied by an international famous brand, the refrigerator is characterized by fast refrigeration and low noise. When there is power outage, the holdover time is up to 24 hours, which provides sufficient time for transferring samples.



Human-oriented

The built-in door handle can prevent damage during transportation and save space. There are 4 universal wheels and 2 leveling foot, which makes it can be moved and fixed easily.



	Model No.	YC-150EW	YC-275EW
Specifications	Cabinet Type	Chest	Chest
	Capacity(L)	150	275
	Internal Size (W*D*H)mm	585*465*651	1019*465*651
	External Size (W*D*H)mm	811*775*929	1245*775*929
	Package Size (W*D*H)mm	875*805*991	1332*810*975
	NW/GW(Kgs)	76/93	87/94
Performance	Temperature Range	2~8°C	2~8°C
	Ambient Temperature	15-43°C	10-43°C
	Cooling Performance	5°C	5°C
	Climate Class	N	N
	Controller	Microprocessor	Microprocessor
	Display	Digital Display	Digital Display
Refrigeration	Compressor	1pc	1pc
	Cooling Method	Direct cooling	Direct cooling
	Defrost Mode	Automatic	Automatic
	Refrigerant	R290	R290
	Insulation Thickness(mm)	110	110
	External Material	SPCC epoxy coating	Sprayed steel plate
Construction	Inner Material	Stainless steel	Stainless steel
	Coated Hanging Basket	1	1
	Door Lock with Key	Yes	Yes
	Backup battery	Yes	Yes
	Casters	4 (2 caster with brake)	4 (2 caster with brake)
	Temperature	High/Low temperature	High/Low temperature
Alarm	Electrical	Power failure, Low battery	Power failure, Low battery
	System	Sensor error	Sensor error
	Power Supply (V/Hz)	220/50	220/50
Electrical	Rated Power (W)	298	-
	Input Power (W)	326	275
	Power Consumption (KWh/24h)	0.8	0.45
	Rated Current(A)	1.48	1.25
	Certifications	ISO, CE	ISO, CE

*The model, parameters and performance specified in this brochure may be changed without prior notice because of product upgrading.
*There may be differences between the product images shown in this brochure and the actual products. When you are buying any product, please check the actual product

Scope of Application

Suitable for storage of biological products, vaccines, drugs, reagents, etc. Suitable for use in pharmacies, pharmaceutical factories, hospitals, centers for disease prevention & control, clinics, etc.

Performance Data / Cooling Curve

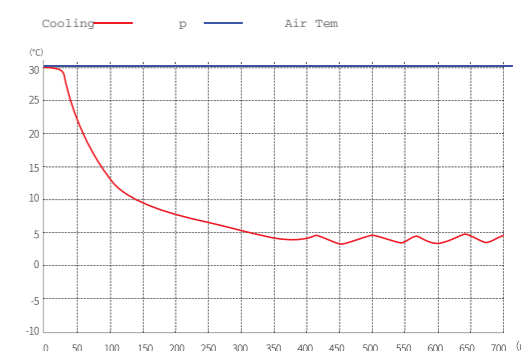
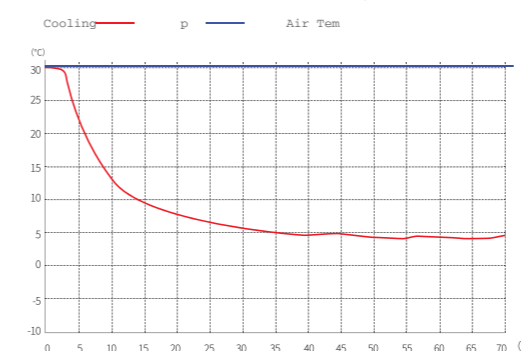

0 ~ 10°C Traditional Medicine Coolers

These traditional showcase coolers are available in 50 to 1500 litre capacities and 1 Door/ 2 Door/ 3 Door variants. They are designed to keep products at the optimum temperature and display them in a convenient easy to access manner..



VC-50
VC-100 (New)

VC-220

VC-333

VC-500

VC-600 NF (New)

VC-700 NF,
VC-1100 NF

VC-1500NF

Technical Specifications



Specification	Gross Volume (Litres)	Dimensions w x d x h (mm)	Temperature Range	Power (w)	Lock	Defrost	No. of Lids / Doors	No. of Shelves	Interior Light	Wheels / Castors	No. of Compressors	Refrigerant
VC-50	50	18 x 20 x 20	0-10°C	65	No	Yes	1	2	1 LED	No	1	R134a
VC-100 (New)	100	18 x 20 x 33	0-10°C	65	No	Yes	1	4	1 LED	No	1	R134a
VC-220	220	21 x 21 x 62	0-10°C	67.9	Yes	Yes	1	3	Normal light	No	1	R600a
VC-333	290	21 x 22 x 73	2 - 8°C	160	Yes	Automatic	1	4	LED light	Yes	1	R134a
VC-500	450	23 x 24 x 78	2 - 8°C	225	Yes	Automatic	1	5	LED light	Yes	1	R134a
VC-600NF (New)	532	25 x 28 x 81	0-10°C	425	Yes	Automatic	1	5	1 LED	4	1	R134a
VC-700NF	680	35 x 24 x 78	1-10°C	410	Yes	Automatic	2	10	2 LEDs	Yes	1	R134a
VC-1100	1050	46 x 29 x 81	0-10°C	550	Yes	Automatic	2	10	2 LEDs	4	1	R134a
VC-1500NF	1495	71 x 27 x 82	1-10°C	875	Yes	Automatic	3	15	5 LEDs	Yes	1	R134a

Model	Volume (L)	Door type	Shelves	Power	Dimensions (wxdxh) mm	Temperature range	Refrigerant	No. of Compressors
VC-1225 Premia	1225	2 Hinge	10	420W	1215x710x2050	+1°C ~ +10°C	R134a	1
VC-1250 Premia	1250	2 Hinge	10	412W	1260x750x2092	+1°C ~ +10°C	R134a	1
VC-1800 Premia	1800	3 Hinge	15	675W	1880x750x2092	+1°C ~ +10°C	R134a	1
VC-1825 Premia	1825	3 Hinge	15	580W	1830x710x2050	+1°C ~ +10°C	R134a	1

Electricals: 220V/50Hz/Single Phase

Specifications are subject to change without prior notice due to continuous product development

Working condition for open chillers/glass door freezer is class 3 (Room Temp. 25°C and 60%RH)

0 ~ 10°C Medical Refrigerators & Freezers in Stainless Steel

These Trufrost Reach-Ins are available as Chillers or Freezers, and come with 1, 2 or 4 door options. Available in a choice of two refrigeration systems - Ventilated or Static with fan, these are offered in capacities ranging from 600 - 1350 litres. There are different models to address the wide-ranging needs.



Available Models
G 600 TN

Available Models
G 600 TNM, G 600 BTM

Available Models
G 1210 TNM, G 1210 BTM

Technical Specifications



Product	Model	Cooling System	Product Dimensions W*D*H (mm)	Volume (Litres)	GN (530 x 325mm) compatibility	Product Weight (Kgs.)	No. of Doors / Drawers	No. of Shelves	Temperature Range (°C)	Refrigerant	Input Power (Watts)
Reach In Refrigerators	G 550 TNM	Ventilated	680*760*1965	550	-	105	2	3	2 ~ +10	R 134a	350
	G 600 TN	Ventilated	680*710*2010	600	-	83	1	5	2 ~ +10	R 134a	305
	G 600 TNM	Ventilated	680*710*2010	600	-	115	2	3	2~+10	R134a	220
	G 1210 TNM	Ventilated	1200*745*1950	1200	-	135	4	6	-2~+8	R134a	408
Reach In Freezers	G 600 BTM	Ventilated	680*710*2010	600	-	126	2	3	-22~-18	R404A	615
	G 1210 BTM	Ventilated	1200*745*1950	1200	-	135	4	6	-22~-17	R404A	741
Reach In Refrigerators with Glass Door	GN 740 TNG	Ventilated	740*830*2010	700	GN2/1	-	1	3	2~+10	R134a	-
	GN 740 BTG	Ventilated	740*830*2010	700	GN2/1	-	1	3	-15~-18	R404a	-
	GN 1480 TNG	Ventilated	1480*830*2010	1410	GN2/1	-	2	6	2~+10	R134a	-
	GN 1480 BTG	Ventilated	1480*830*2010	1410	GN2/1	-	2	6	-15~-18	R404a	-

Electricals: 220V/50Hz/1 Phase

Specifications are subject to change without prior notice due to continuous product development

-20°C
~ **+20°C**

Mobile Freezers/Coolers Combo

The T36 and TWW-95 portable freezer/cooler combos come with the latest two temperature control system function. They are great portable refrigerator/freezers to meet a variety of refrigeration needs be it for transportation of bio-medical products or carrying refrigerated or frozen foodstuff for a picnic, or on the road camping for months.



T-36, T-50

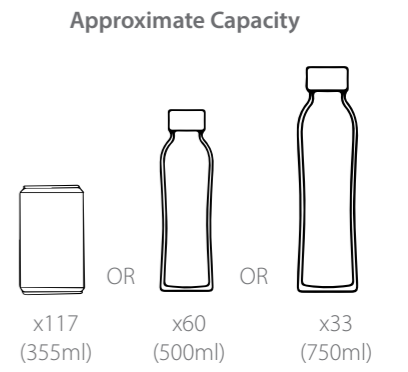
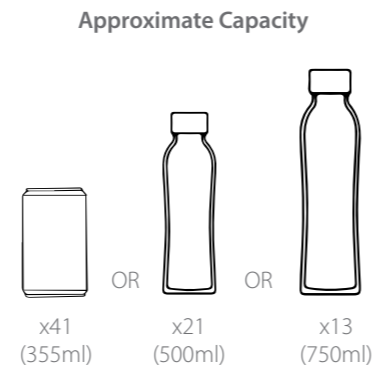
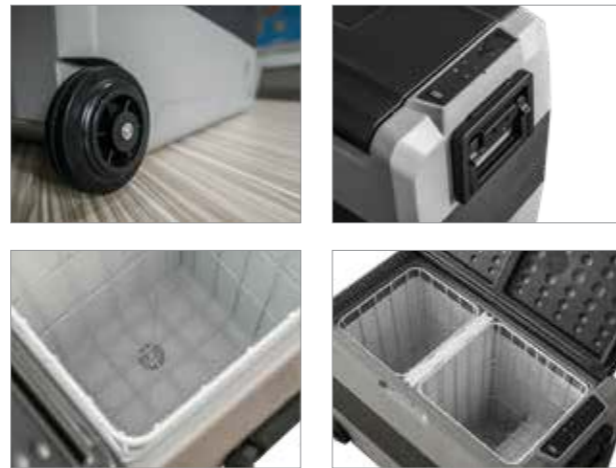

TWW-95



Key Features:

- ◆ Detachable battery lasts 4 - 24 hours for outdoor activity
- ◆ Dual compartments with individual temperature control
- ◆ LG compressor for superior cooling performance
- ◆ Three stage battery protection system prevents vehicle run out of battery
- ◆ Car & home dual use (DC/AC)
- ◆ Shockproof and durable design for handling rocky road
- ◆ Wire storage baskets, interior drain plug and LED light
- ◆ LED digital display control panel for easy operation
- ◆ Big wheels and heavy telescoping handle
- ◆ Reverse/removable fridge door design
- ◆ Safe to run less than a 45-degree angle in short time
- ◆ Mobile phone app control at your fingertips for convenience
- ◆ Classic fridge slide ensures easy access to cooler, and makes it stays in position when you are driving in rough road.

Key Features:

- ◆ DUAL TEMPERATURE CONTROL: Detachable sensor divider can switch single temperature zone to two separate temperature zone (Fridge/freezer) in one refrigerator.
- ◆ FREEZES WITHOUT ICE: -20°C to 20°C powerful chilling performance.
- ◆ CAR BATTERY PROTECTION: With temperature memory function and Three stages battery protection system prevents vehicle run out of battery.
- ◆ INTERIOR: Built-in LED light, interior drain plug for easy clean, and wire storage basket
- ◆ EXTERIOR: Magnetic foldable handle, USB Port, reliable wheels for easy carrying, digital display control panel, removable fridge door design for full access.
- ◆ High performance compressor: Name compressor offers superior cooling performance.
- ◆ Fit anywhere: Car/Jeep/Truck/Home/Dorm/Cottage/Garage/ RV/Boat/ Outdoor (DC/AC).
- ◆ Rugged design: Shockproof and durable design for handling rocky road. Safe to run less than a 45° angle in short time
- ◆ Quiet operation: Less than 45db, like living in quiet suburb.
- ◆ ENERGY SAVING (MAX & ECO MODE): Two different modes can be adjusted as needed. The compressor will stop operating when the freezer reaches the set temperature. The compressor will restart to operating when the temperature in the box has risen from 6°F to 9°F.



Technical Specifications

Model	T-36	T-50	TWW-95
Cooling type	Forced Air Cooling	Forced Air Cooling	Forced Air Cooling
Defrost	Manual	Manual	Manual
Refrigerant	R134a	R134a	R134a
Noise level(db)	45	45	45
Ambient temperature	-40°~65°C	-40°~65°C	-40°~65°C
Temperature range	-20°~20°C	-20°~20°C	-20°~20°C
Sensor type	NTC	NTC	NTC
Temperature controller	Digital Control	Digital Control	Digital Control
Display	LCD Display	LCD Display	LCD Display
Voltage/Frequency	DC 12/24v; AC 220~240v	DC 12/24v; AC 220~240v	DC 12/24v; AC 220~240v
Power	60W	60W	60W
Electricity	DC 5.0/2.5A; AC 1.5A~0.5A	DC 5.0/2.5A; AC 1.5A~0.5A	DC 6.0/3.0A; AC 1.5A~0.7A
Capacity	36L	50L	95L
Net/Gross weight	14KG /16KG	15.5KG /17.5KG	27KG /29KG
Dimensions (W*D*H)	360*723*365 mm	360*723*458 mm	571*896*462 mm
Qualifications	CE, CB, ROHS, ISO 9001:2015, ISO 13485:2016, FDA, WHO-GMP	CE, CB, ROHS, ISO 9001:2015, ISO 13485:2016, FDA, WHO-GMP	CE, CB, ROHS, ISO 9001:2015, ISO 13485:2016, FDA, WHO-GMP

Specifications are subject to change without prior notice due to continuous product development

2~8°C Medical Vaccine Carriers

Trufrost Vaccine Carriers are specialised ice boxes used in the transport and/or storage of vaccines where power supply/refrigeration poses a challenge. The carefully crafted and placed icepacks in the already insulated boxes are designed to store vaccines and/or life saving medicines at optimal temperatures even at high ambient temperatures 43°C for up to 48 hours.



KPR-13, KPR-36



Shoulder Strap



Thermometer



Password Lock



Partition

Key Features:

- ◆ Easy to carry handle and removable shoulder strap
- ◆ Internal body in food grade polypropylene
- ◆ Effective protection against temperature loss with seal ring and stainless steel latches
- ◆ Highly effective 40 mm polyurethane foam insulation
- ◆ Two models with 13 and 36 litre capacities

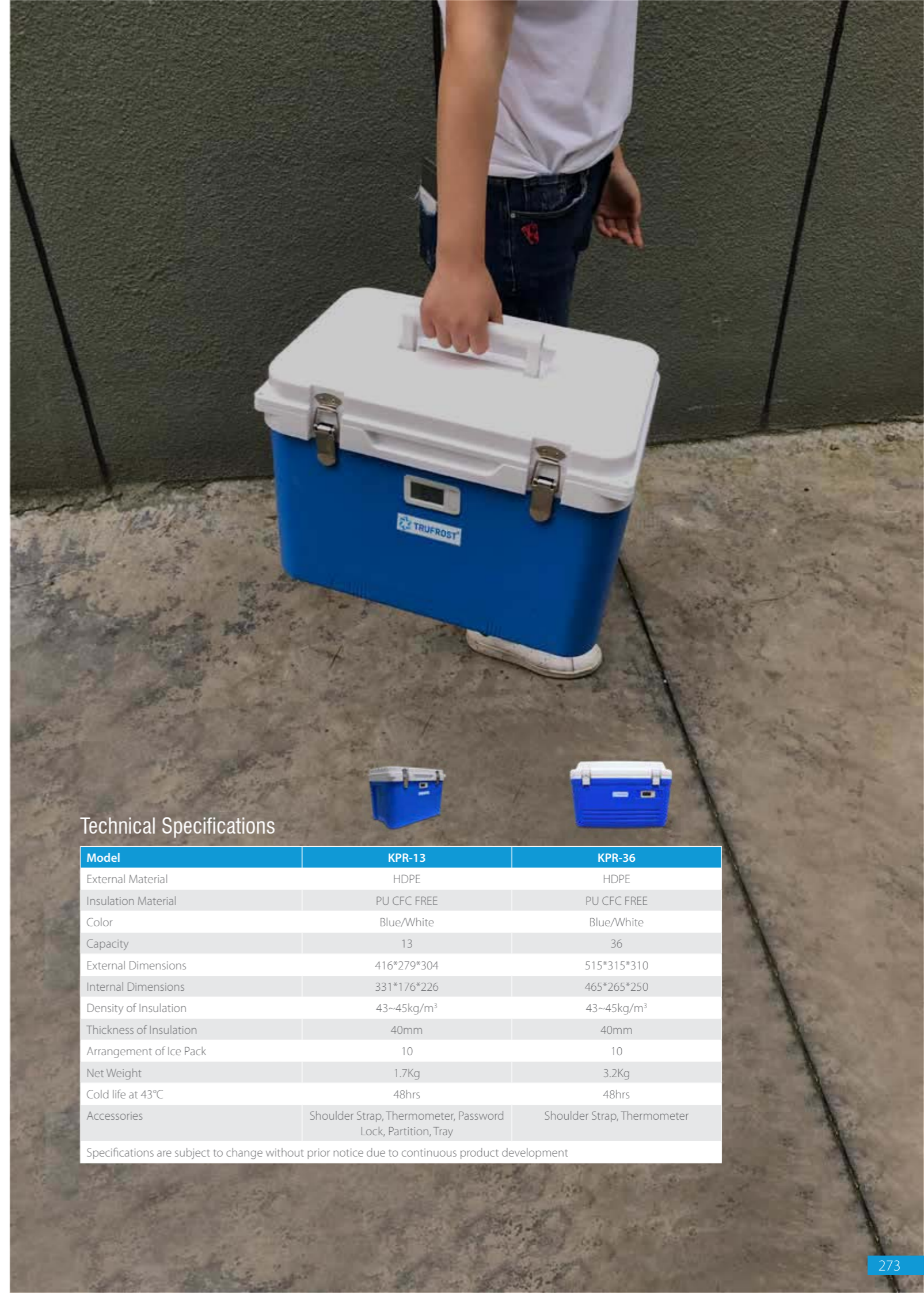

Technical Specifications

Model	KPR-13	KPR-36
External Material	HDPE	HDPE
Insulation Material	PU CFC FREE	PU CFC FREE
Color	Blue/White	Blue/White
Capacity	13	36
External Dimensions	416*279*304	515*315*310
Internal Dimensions	331*176*226	465*265*250
Density of Insulation	43~45kg/m ³	43~45kg/m ³
Thickness of Insulation	40mm	40mm
Arrangement of Ice Pack	10	10
Net Weight	1.7Kg	3.2Kg
Cold life at 43°C	48hrs	48hrs
Accessories	Shoulder Strap, Thermometer, Password Lock, Partition, Tray	Shoulder Strap, Thermometer

Specifications are subject to change without prior notice due to continuous product development

20~24°C Blood Platelet Incubators

The blood platelet incubator is widely used to store blood platelets, biological reagents and chemical products. They are used by hospitals, blood banks, research institutes, laboratories and universities.



MDC-5



MDC-10

Key Features:

- ◆ High accuracy sensor
- ◆ Microprocessor control with inner temperature controlled at 22°C ±2°C
- ◆ Efficient refrigeration system with controlled fan and forced cycle mechanism ensures temperature consistency inside the cabinet
- ◆ Large digital display for easier observation
- ◆ Disinfection by UV light that shuts off automatically when door is opened to prevent harm to human body
- ◆ Double insulated glass door makes observation easy
- ◆ High quality oscillation slide rail for longevity as well as low noise

Safety Control System:

- ◆ Alarm mode monitors ambient temperature and system state to ensure safety and reliability of storage conditions.
- ◆ High/Low temperature alarm, thermostat malfunction alarm, power failure alarm in 72 hours, battery back-up malfunction alarm and door ajar alarm
- ◆ Audio and visual alarm



	Model No.	MDC-5	MDC-10	
Specifications	Shelf/Drawer	Drawer	Drawer	
	Cooling Method	Forced - Air Cooling	Forced - Air Cooling	
	Defrost	No Frost	No Frost	
	Refrigerant	R134a	R134a	
	Power Consumption (kWh/24h)	2.69	4.4	
	Noise (db)	49	50	
	Ambient Temperature (C)	10 ~ 32	10 ~ 32	
	Temperature Range (C)	20 ~ 24	20 ~ 24	
	Cooling System	Compressor Brand/QTY	Embraco/1	Embraco/1
		Sensor	NTC	NTC
Temperature Controller		Microprocessor	Microprocessor	
Display		Digital Display	Digital Display	
Power	Voltage/Frequency (V/Hz)	220V/50Hz	220V/50Hz	
	Power (W)	197W	280W	
	Current (A)	0.9	1.27	
Material	Inside Material	SUS	SUS	
	Outside Material	Color Sprayed Steel	Color Sprayed Steel	
	Insulation	PUF	PUF	
Size	Capacity (L/Cu.ft)	5	10	
	Blood Bags (450ml)/Drawer	10/5 Layers	20/10 Layers	
	Net/Gross Weight (Kg)	60/65	80/86	
	Exterior Size (WxDxH) (mm)	522 x 600 x 1050	522 x 600 x 1300	
	Interior Size (WxDxH) (mm)	427 x 360 x 467	432 x 462 x 728	
	Package Size (WxDxH) (mm)	585 x 700 x 1205	588 x 677 x 1440	
	Alarm	High/Low Temperature	Y	Y
Power Failure		Y	Y	
Sensor Malfunction		Y	Y	
Low Battery		Y	Y	
Door Ajar		Y	Y	
Accessories	Castor	Y	Y	
	Outer Door/Type	1 (Foamed Glass Door)	1 (Foamed Glass Door)	
	Test Hole	Optional	Optional	
	Light	UV Light	UV Light	
	Temperature Recorder	Optional	Optional	
Other	Certifications	ISO9001, 13485, 14001, CE	ISO9001, 13485, 14001, CE	

Specifications are subject to change without prior notice due to continuous product development





Manufacturing & Quality

Our products are manufactured in the most advanced factories located across the world, most of them highly automated and robotized. Every Trufrost & Butler product complies to the highest standards of quality & consistency, and comes with one or more global certifications such as CE, UL, NSF, CCC, CB, ROHS, OHSAS, ETL, ISO 9001, ISO 13485 and ISO 14001 among others.





Trufrost Butler Experience Centres

Recognising the latent need of its prospective customers to 'touch & feel' the equipment before purchase, Trufrost has set up a Company driven Experience Centre at its Corporate office in Gurgaon. But that is not all there is to it. You will find the key products of Trufrost and Butler on display in an aesthetic, yet functional manner – in the actual setting of a bar, a coffee shop, a professional kitchen, an ice cream parlour and so on. Here the prospective customers can visualise the use of the various equipments in their eventual environments and also allows them to get store design tips and space saving ideas, ahead of their committing themselves to making an investment and ensuring that it remains judicious. The Experience Centre can be visited by prior appointment on a working day.

In addition, franchised Trufrost Butler Experience Centres have been set up at Hyderabad and Amritsar and a few more are in the process of being set up in other cities. Please stay tuned on our website for an updated list of Trufrost Butler Experience Centres.



Design Support

Our focus is not merely in selling our equipment but in delivering holistic solutions that work for our customers and help them grow their business. We draw immense satisfaction when our customers turn into repeat clients and refer other customers to us. Our two brands – Trufrost & Butler work in tandem to provide holistic solutions that are contemporary, energy efficient, space saving, technologically advanced, and yet do not burn a hole in your pocket.

Whether you are setting up a cafe, a patisserie or a bakery, fine dining or a quick service restaurant, commercial or a cloud kitchen, bar or a pub, an ice cream parlour or a juice bar, supermarket or a convenience store, butchery or a seafood store, or planning a walk-in coldroom or a refrigerated warehouse, you can call us for help in offering you the right advice on equipment selection as well as design. Just drop a mail to info@trufrost.com with your name, contact number and location, and we will have our Design Cell to promptly get in touch with you.



Experience Centres



Gurugram



Hyderabad



Amritsar



Culinary Centre, Gurugram

Our Clients

Here's a partial list of our clients, most of whom are our repeat customers.

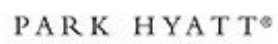

MIDDLE EAST

Trufrost is now in UAE

Trufrost has recently established its own subsidiary, **Trufrost & Butler LLC** in Sharjah after having bagged a series of prestigious projects in UAE, Bahrain and Africa. With this foray, Trufrost sees a further acceleration of its presence in this very demanding and quality driven market.

Trufrost & Butler L.L.C.

Flat No. 501, Block – 1, Al Qusais – 1,
Bin Shabib Mall, Dubai, U.A.E

Tel: +971-54-557-9395, +971-55-676-1323

Email: middleeast@trufrost.com

www.trufrost.com



INDIA



Products

Andhra/Telangana :	9319391543	Karnataka :	7303890588
Chennai :	7303890587	Kerala :	7303890587
Chhattisgarh :	7303890590	Maharashtra :	7303890586
Coldroom (North):	8448445701, 7303196612	Mumbai :	7303196614, 9319579748
Coldroom (South):	9319399771, 7303890585	Orissa :	7303890590, 9667795491
Delhi/NCR :	8448759200, 7303890582	Punjab / Haryana :	8448319200, 9319399772
Goa :	7303890586	Rajasthan :	9116116765
Gujarat :	9319579748	UP :	7303196607
Assam/North-East :	9319391542, 9667795491	MP :	9319399770
J & K / Himachal :	8448319200, 9319399772	Uttarakhand :	8448319200, 9319399772
		West-Bengal/Bihar :	7303890590, 9667795491

Coldrooms

Karnataka, Kerala	: 7303890585	Punjab, Haryana, HP, J&K	: 9667798716
Uttarakhand, UP	: 8448445701, 7303196612	West Bengal, NorthEast, Bihar, Odisha	: 9667795491
Maharashtra, Andhra, TamilNadu, Goa	: 9319399771	Maharashtra, Goa, MP, Chhattisgarh	: 9821380888
Rajasthan, Gujarat	: 9116116765	Mumbai	: 9821380888
Delhi NCR	: 8448445701, 7303196612		

CORPORATE OFFICE

1214 & 1215, Tower B, Emaar Digital Greens, Golf Course Extn. Road, Sector 61, Gurugram - 122011 (India)

Tel: +91-124-4246560 Email: info@trufrost.com www.trufrost.com





www.trufrost.com